

Architecture

for + with + by

Refugees



Architecture for Refugees

=

open source online platform
to collect and share knowledge
on “refugee architecture”



Architecture
for + with + by
Refugees

the Users
+
Dennise Castillo
Henrik Ceccaroli
Zsófia Glatz
Bence Komlósi

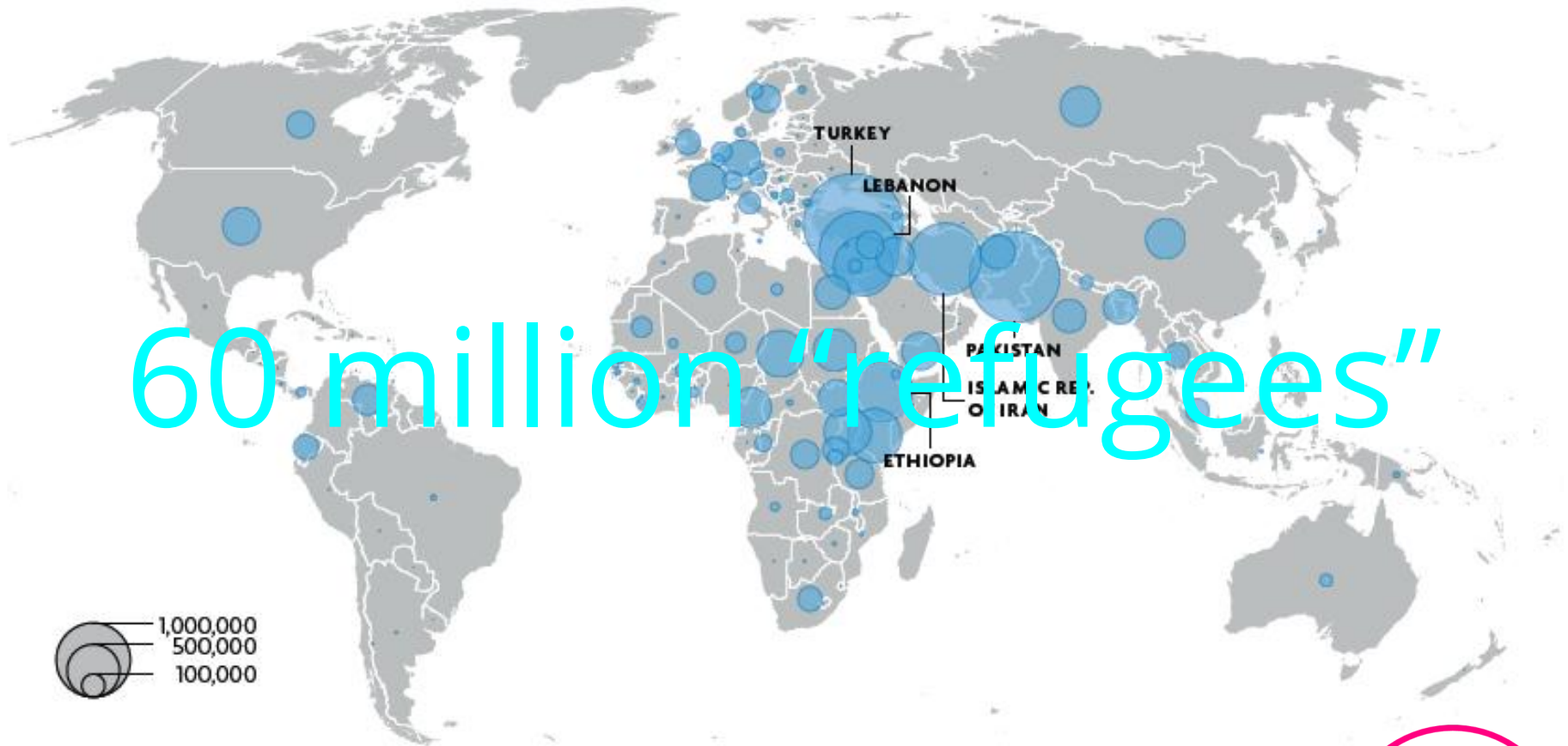

60 million "refugees"

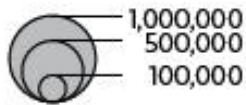

The boundaries and names shown and the designations used on this map do not imply official endorsement or acceptance by the United Nations. A country is listed if it featured among the top-5 per year.



TOGETHER

by Richard Sennett

“Living with people who different - racially, ethnically, religiously or economically - is one of the most urgent challenges facing civil society today. Together argues that cooperation needs more than good will: it is a craft that requires skill. In modern society traditional bonds are waning, and we must develop new forms of secular, civic ritual that make us more skilful in living with others. From medieval guilds to today’s social network, Richard Sennett’s visionary book explores the nature of cooperation, why it has become weak and how it can be strengthened.”



Architecture
for + with + by
Refugees



KELETI PÁLYAUDVAR

?

+

!

Architecture
for + with + by
Refugees



BUDAPEST

Architecture
for + with e by
Refugees

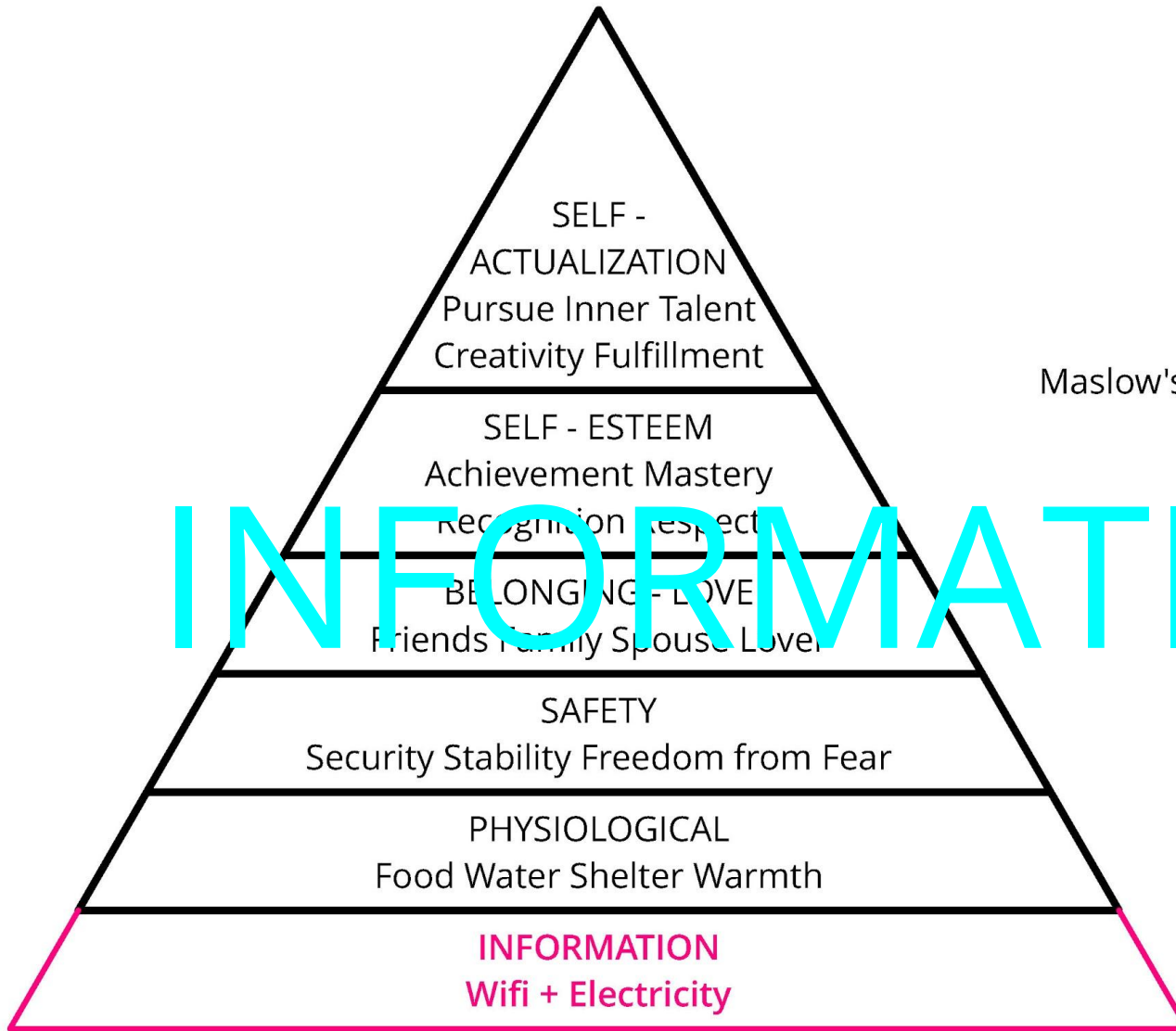

Maslow's *Hierarchy of Needs*

INFORMATION

+

Architecture
for + with + by
Refugees

INFORMATION

by Rachel Kaplan,
Stephen Kaplan and Robert Ryan

*“Central to the framework is the
nation of INFORMATION. For more
basic than money, INFORMATION
is what really drives our world.”*

p.7. With People in Mind: Design and Management of Everyday Nature



Architecture
for + with + by
Refugees

Roma - Magyar?!
Fehér - Fekete?!
EURÓPAI - SZÍR?!
...
Nem érdekel, nekünk ők csak emberek

Alapvetően úgy tűnik, hogy a fejlett világ egy jelentős része az embert próbálja ismét a középpontba állítani, ha építészeiről van szó. Építészeiről, amely véd, biztonságot ad és tanít. Keretet ad az embereknek, hogy nyugodtan, békésen és egészségesen élhessenek.

Ehhez képest ma a háború súlytotta országokból menekülőik illetve a gazdasági menekültek egyike sem kapja meg még csak a minimális emberséget sem. Ami ma Magyarországon és Budapesten folyik a migráns ügy kezelésében az szomorú és nagyon kevés. Ez így biztosan nem mehet tovább. Ezeknek az embereknek segítségre van szükségük. Az, hogy ki hogyan segít, azt mindenki maga döntheti el. Szerintünk mindenki abban segítsen, amiben a legjobb. Mi építészekként ezzel a rövid, gondolatébresztő cikkkel szeretnénk felhívni a pillanatnyi helyzetre az építészársadalom figyelmét. Alapvetően embereként kellene, hogy segítsünk, de mi építészek vagyunk, így az otthonteremtésben, fedélkészítésben tudunk a legtöbbet nyújtani. Emellett persze lehet pénzt utalni, lehet menni önkéntesként ételt osztani, lehet posztolni a közösségi média oldalakon. A lényeg, hogy ha mindenki egy kicsit is segít, akkor az nagyon nagy fejlődést tud elindítani!

Aki egyszer életében bármilyen okból elhagyta a hazáját - otthonát, az talán könnyen megérti, hogy ez milyen körülmények között történhet. A nehézségek kell, hogy minden embernek meg kell küzdenie. Ma az is nagy támogatás, ha az embernek nemcsak a keresztségben mindent amitől élni felel kap, az orrási segítségek formájában érez. Mi egy kicsit szízzel, sok posztal és gondolattal szeretnénk segíteni ezekben a nehéz sorsú, de annál erősebb emberek a további útján a céljuk eléréséhez. Egy Ecdorából származó építész ismétlünk a kezdetekről ezekre és ötletekkel járul hozzá, hogy ez a nagyon nehezen megoldható helyzetet is elől haladjon. Gondoljunk külön és együtt, cselekedjünk külön és együtt! A lényeg, hogy mindenki próbáljon akárcsak egy kicsit is hozzáadni a munkához, hogy a kezdeményezés valóban segíthessen.

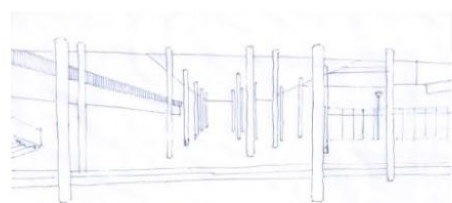

a helyszín, a struktúra - skicc: Dennise Castillo

a teljes galéria megtekintéséhez kattintson a képre

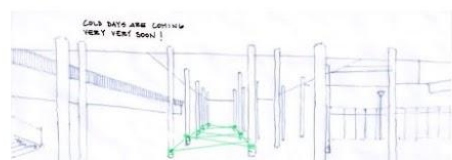

emeljük el a talajtól - skicc: Dennise Castillo

a teljes galéria megtekintéséhez kattintson a képre

állást kínál | állást keres

Építész tervező | Potzner Ferenc
Építész - projekt munkatárs | A-REAL INGATLANFORGALMAZÓ KFT
Építészmérnök | Horizont 4. Kft. 2700 Cegléd, Kossuth tér 4.
szerkesztőségi titkár | Építészfórum

@epiteszforum követése Follow
@epiteszforum
RSS/Atom csatornák

ef epiteszforum.hu 10,660 likes
Liked Shop Now

EF hírtévé -

Az epiteszforum.hu 2000 óta gyűjt, rendszerez és az interneten szabadon hozzáférhetővé tesz kortárs építészeti, művészeti és design alkotásokat, valamint írásokat az építészet, város- és vizuális kultúra területéről. Ha van olyan munkája, írása, tanulmánya, amely Ön szerint bemutatásra érdemes, küldje el a szerkesztőségnek -

szerkesztők | klubtagok

diskurzus | friss | népszerű

- Igaza van és elnézést kérek. Az ui... Pákozdi Imre
A kávézás szabadsága
- Pákozdi Úr! Neeeeee mááááá! gádor
A kávézás szabadsága
- De hát ez nem mai... Ez a múlt század... Pákozdi Imre
A kávézás szabadsága
- Íme, egy gyöngyszem a CSÖK... Hartmann György Sándor
Homlok-CSÖK
- A politikuskok és a szegedi hidak. Mi mindent... alföldi2011
Portlód vagy inkább Szeged? Mi...
- Csatlakozom Jánoshoz - én sem érzem... EZ
Hiteles tudósítások?
- (egyszeri olvasóként Zöldi Anna fenti... mB
Hiteles tudósítások?
- kedves Csaba, a hitelesség szó címként... Zöldi Anna
Hiteles tudósítások?

INFORMATION



KNOWLEDGE



Architecture
for + with + by
Refugees

KNOWLEDGE

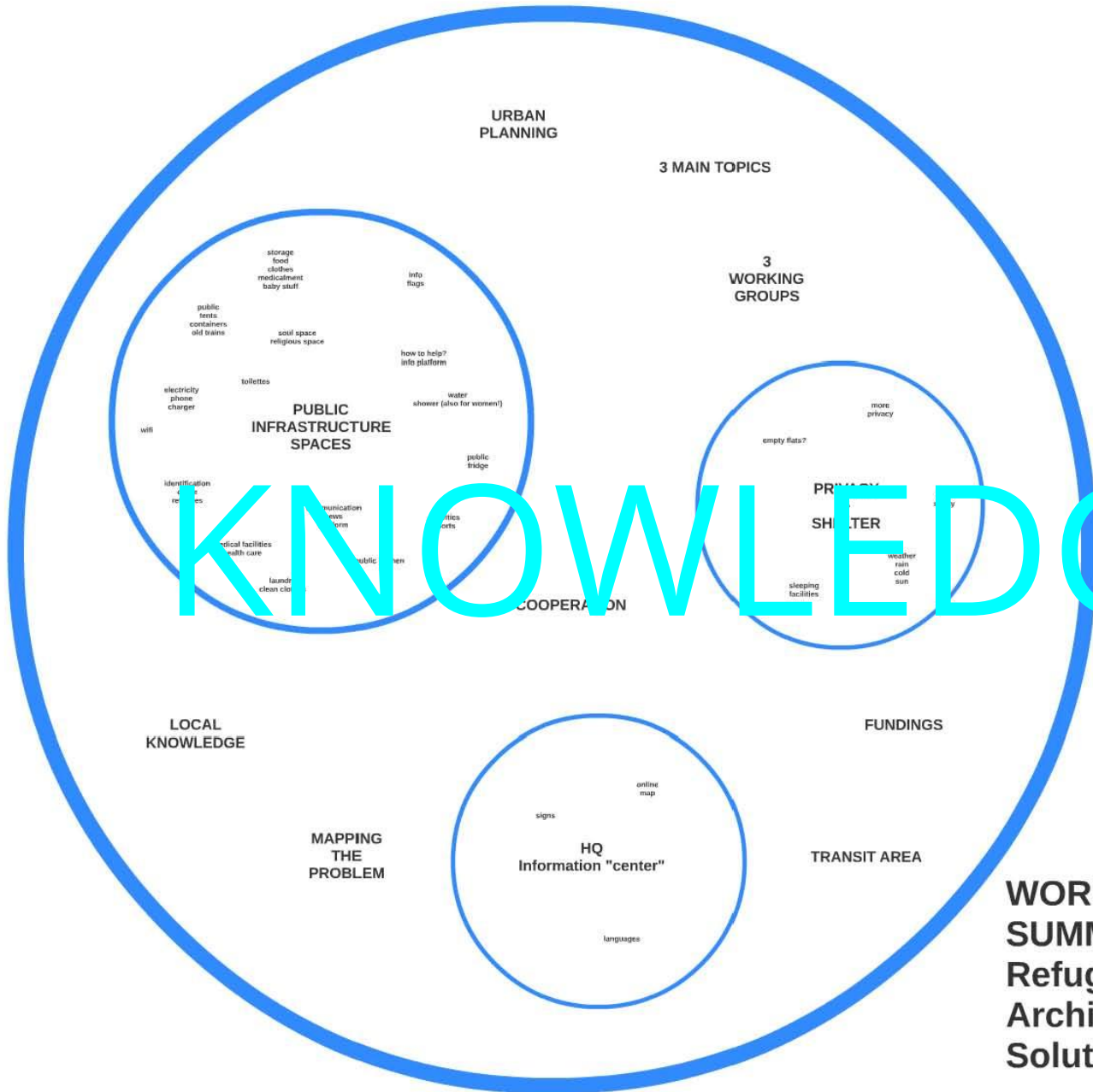

WORKSHOP 1.0
SUMMARY
Refugees
Architecture
Solutions



FUGA

csatlakozz

FUGA támogatói kör
Felhívás

A FUGA 2014. szeptember 15-én volt a második, de az új emberek és az új projektek, a képzés, az előadások, az események, a tervek, a megvalósítások, a megvalósítások és az emberek közötti kapcsolat. A FUGA célja, hogy megmutassa az emberek közötti kapcsolatokat, és hogy megmutassa az emberek közötti kapcsolatokat. A FUGA célja, hogy megmutassa az emberek közötti kapcsolatokat, és hogy megmutassa az emberek közötti kapcsolatokat.

FUGA támogatói kör:
Művészeti Szervezetek, Kulturális Intézmények, Oktatási Intézmények, Oktatók, Tanárok, Hallgatók, Szabadidősportolóknak, Sportolók, Szabadidősportolóknak, Sportolók, Szabadidősportolóknak, Sportolók

Művészeti Szervezetek: Magyar Művészeti Intézet, Magyar Művészeti Intézet, Magyar Művészeti Intézet
Kulturális Intézmények: Magyar Művészeti Intézet, Magyar Művészeti Intézet, Magyar Művészeti Intézet
Oktatási Intézmények: Magyar Művészeti Intézet, Magyar Művészeti Intézet, Magyar Művészeti Intézet
Oktatók, Tanárok, Hallgatók: Magyar Művészeti Intézet, Magyar Művészeti Intézet, Magyar Művészeti Intézet
Szabadidősportolóknak, Sportolók, Szabadidősportolóknak, Sportolók: Magyar Művészeti Intézet, Magyar Művészeti Intézet, Magyar Művészeti Intézet

A menekültügy margójára

A side note on the refugee crisis

DANIEL GASTAL, KONTÓ KATALIN

DANIEL GASTAL, KONTÓ KATALIN

DANIEL GASTAL, KONTÓ KATALIN

DANIEL GASTAL, KONTÓ KATALIN

DANIEL GASTAL, KONTÓ KATALIN

DANIEL GASTAL, KONTÓ KATALIN

DANIEL GASTAL, KONTÓ KATALIN

DANIEL GASTAL, KONTÓ KATALIN

DANIEL GASTAL, KONTÓ KATALIN

DANIEL GASTAL, KONTÓ KATALIN

DANIEL GASTAL, KONTÓ KATALIN

DANIEL GASTAL, KONTÓ KATALIN

2015 10 22 - 11 08

n a

SHARING

Architecture
for + with + by
Refugees

03.

| projekt
látványterve

| 15. Velencei Nemzetközi Építészeti Biennálé
Magyar pavilon - kurátori pályázat

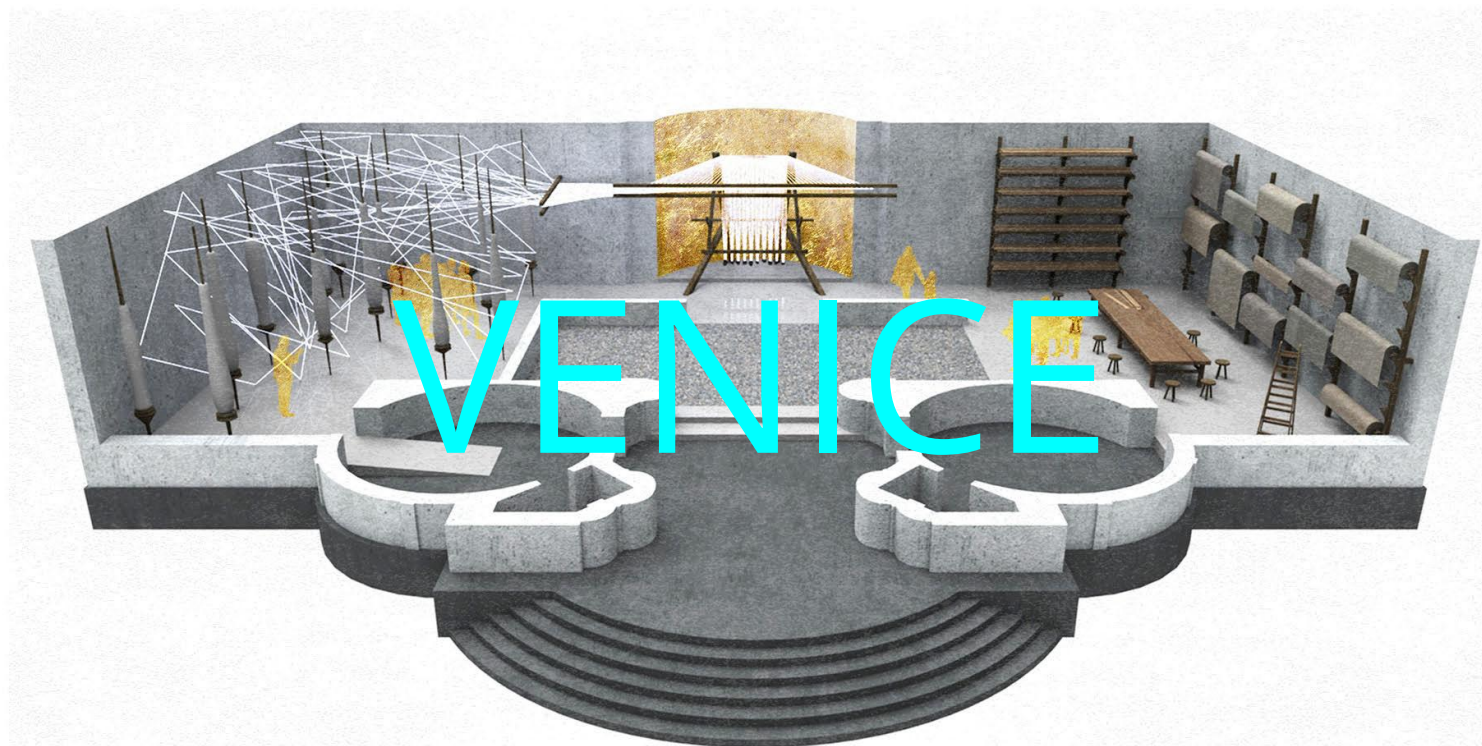

PROJECT HOME WORK PROTOCOL

Our work protocol will follow subsequent activities as described:

1. TORSHOV SYMPOSIA AND WORKSHOPS

FIRST DAY SYMPOSIA

In a first attempt to explore the grounds of Torshov, we will summon a kickoff symposia that will focus on the experiences from the community. This community will include all participants: refugees, students and invited collaborators, such as academics and experts on the field. We will ask for voluntary testimonies, focusing on notions of home and encounters of domesticity while being in transit. These testimonies will become a body of knowledge from which to extract the content and program of our designs. Topics of discussion will be related to the basic functions of a home: such as eating, sleeping/resting, hygiene, communication, play.

DESIGN-BUILD WORKSHOPS

Parallel to the symposia, we will run design-build workshops for continuous seven days at Torshov refugee site, Transittmottak. The workshops will group multiple teams. Each team will have ten members (eight collaborators and two leaders) and will design and build artifacts that reflect on one of the following basic functions:

DESIGN THEMES

Each workshop will have an assigned theme, given by raffle. Design themes will include:

- sleeping
- eating
- communicating (to people left "home", with each other, with anyone...)
- bathing
- excretion
- playing
- jolly joker

Jolly jokers are functions that are open to be discussed and assigned at the first day symposia by all teams. Other themes may change depending on these discussions.

DESIGN GUIDELINES

Each artifact will be made of a certain maximum amount of material and a certain maximum size (to be transportable in a pickup truck). We will have formal constraints to guide the designs: a defined volume to occupy and a common face for all elements to be later assembled together. All units should be inhabitable. These constraints will ensure that artifacts can be coupled together forming a functional unit. This assembly will be set to be tested at the Transittmottak, will be disassembled (as autonomous artifacts) throughout the city, and later reassembled at the Triennial. [1]

CONSTRUCTION

Teams will have seven days to design and build their artifacts. The organizers will promote educational guidelines amongst workshop leaders. Team leaders will be encouraged to promote democratic work practices amongst all team members. These practices will be discussed throughout the workshop so that all team leaders are equipped with a range of possible methodologies: voting, consensus, creation of sub-teams, self-assignment of distinct roles, target setups, time control, communication, cooperation within the group and with the other teams, project management, etc. The goal is that the process of design and building runs in parallel to that of the construction of the community.

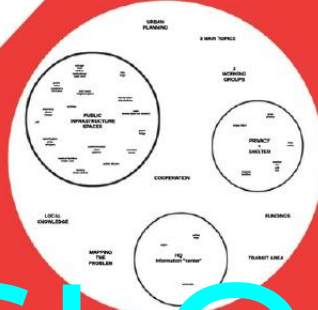

OSLO



Architecture
led with & by
Refugees

Shelter in Dignity: Response to refugee crisis 2015. Budapest
Conducted, curated by Bence Komlós

HELLO WOOD 2010-2015

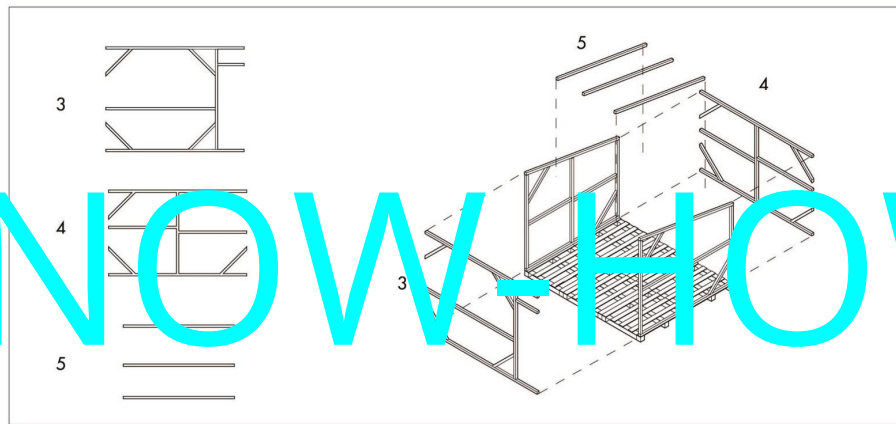
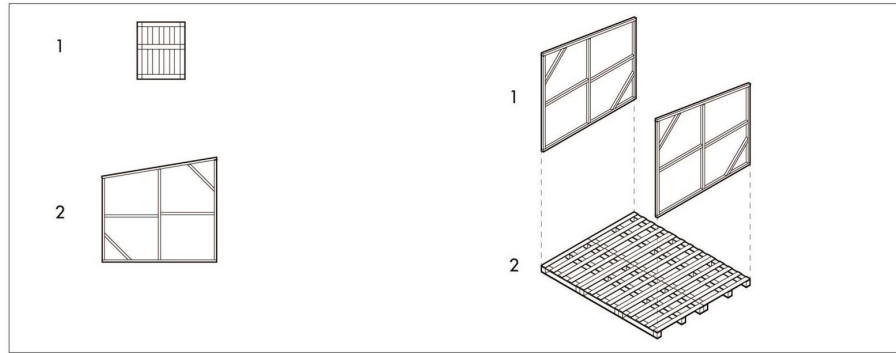

KNOW-HOW

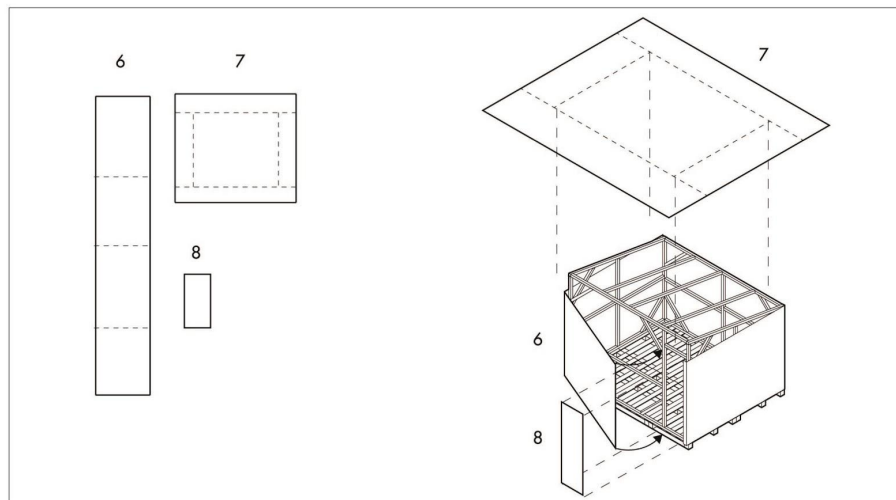

KNOW-HOW

Architecture
for + with + by
Refugees

KNOW-HOW

Architecture
for + with + by
Refugees

REFUGEE ORIENTED and BASED development
generate and empower COLLABORATION
SHARING existing INFORMATION
CONNECT people
think GLOBAL, act LOCAL
LONG-TERM influence
raise FUNDS
build up a COMMUNITY

GOALS

Architecture
for + with + by
Refugees

REFUGEE ORIENTED and BASED development

generate and empower COLLABORATION

SHARING existing INFORMATION

CONNECT people

think GLOBAL, act LOCAL

LONG-TERM influence

raise FUNDS

build up a COMMUNITY

Architecture

for + with + by

Refugees

REFUGEE ORIENTED and BASED development

generate and empower

COLLABORATION

SHARING existing INFORMATION

CONNECT people

think GLOBAL, act LOCAL

LONG-TERM influence

raise FUNDS

build up a COMMUNITY

Architecture
for + with + by
Refugees

REFUGEE ORIENTED and BASED development
generate and empower COLLABORATION

SHARING existing INFORMATION

CONNECT people
think GLOBAL, act LOCAL
LONG-TERM influence
raise FUNDS
build up a COMMUNITY

Architecture
for + with + by
Refugees

REFUGEE ORIENTED and BASED development
generate and empower COLLABORATION
SHARING existing INFORMATION

CONNECT people

think GLOBAL, act LOCAL

LONG-TERM influence

raise FUNDS

build up a COMMUNITY

Architecture
for + with + by
Refugees

REFUGEE ORIENTED and BASED development
generate and empower COLLABORATION
SHARING existing INFORMATION
CONNECT people

think GLOBAL, act LOCAL

LONG-TERM influence
raise FUNDS
build up a COMMUNITY

Architecture
for + with + by
Refugees

REFUGEE ORIENTED and BASED development
generate and empower COLLABORATION

SHARING existing INFORMATION

CONNECT people

think GLOBAL, act LOCAL

LONG-TERM influence

raise FUNDS

build up a COMMUNITY

Architecture
for + with + by
Refugees

REFUGEE ORIENTED and BASED development
generate and empower COLLABORATION
SHARING existing INFORMATION
CONNECT people
think GLOBAL, act LOCAL
LONG-TERM influence
raise FUNDS
build up a COMMUNITY

Architecture
for + with + by
Refugees

REFUGEE ORIENTED and BASED development
generate and empower COLLABORATION

SHARING existing INFORMATION

CONNECT people

think GLOBAL, act LOCAL

LONG-TERM influence

raise FUNDS

build up a COMMUNITY

Architecture

for + with + by

Refugees

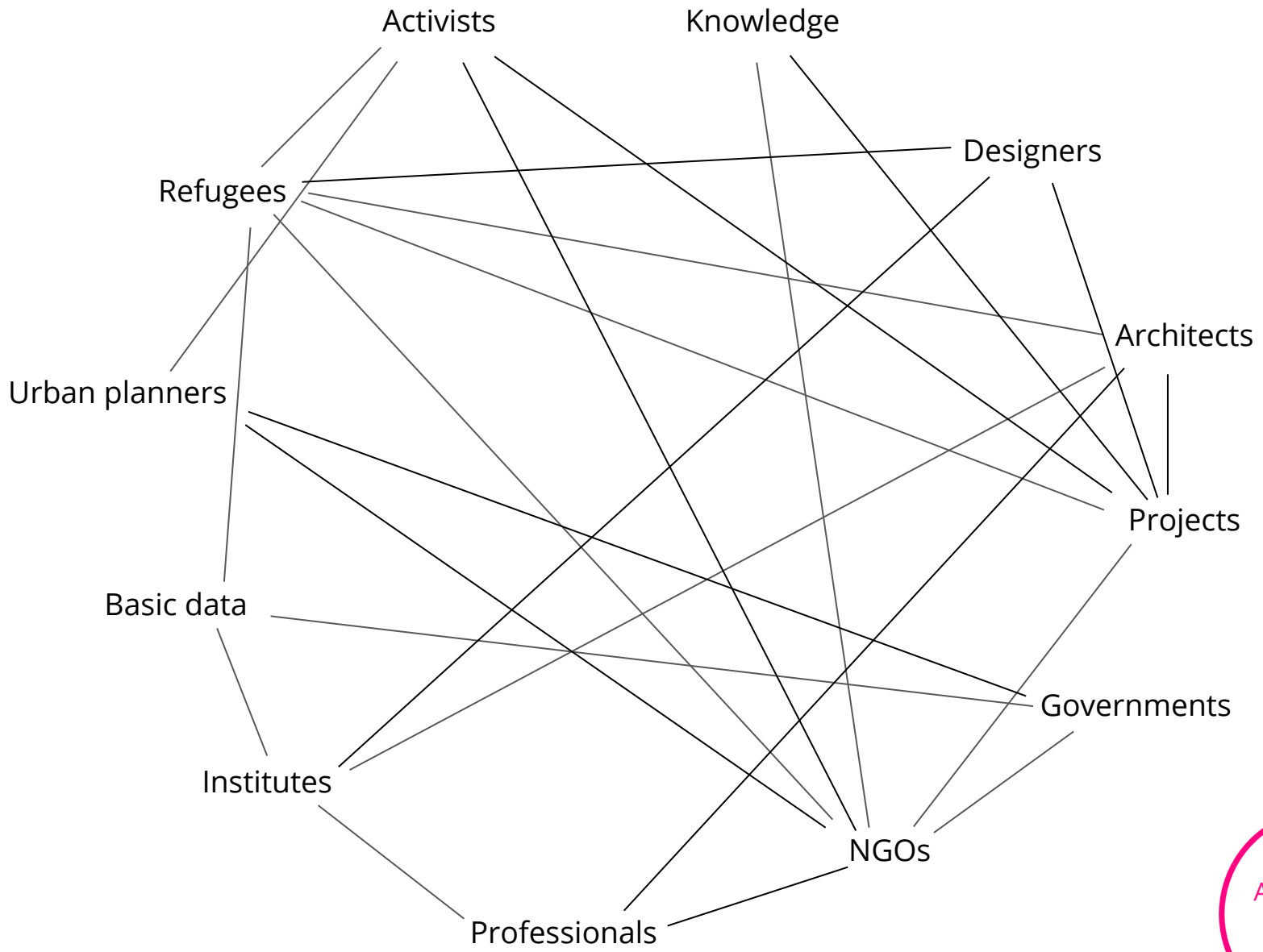

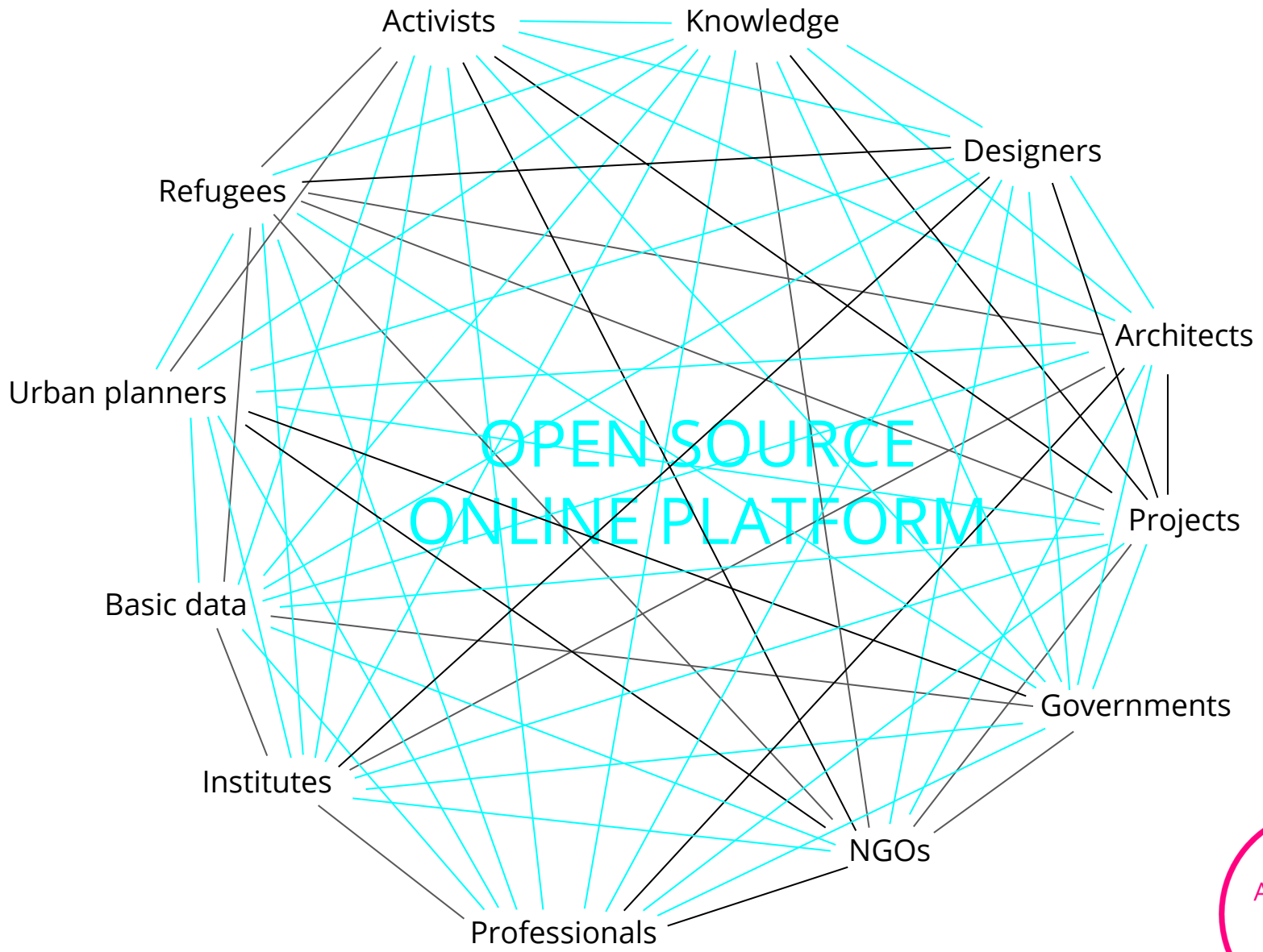

OPEN SOURCE ONLINE PLATFORM



Architecture
for + with + by
Refugees

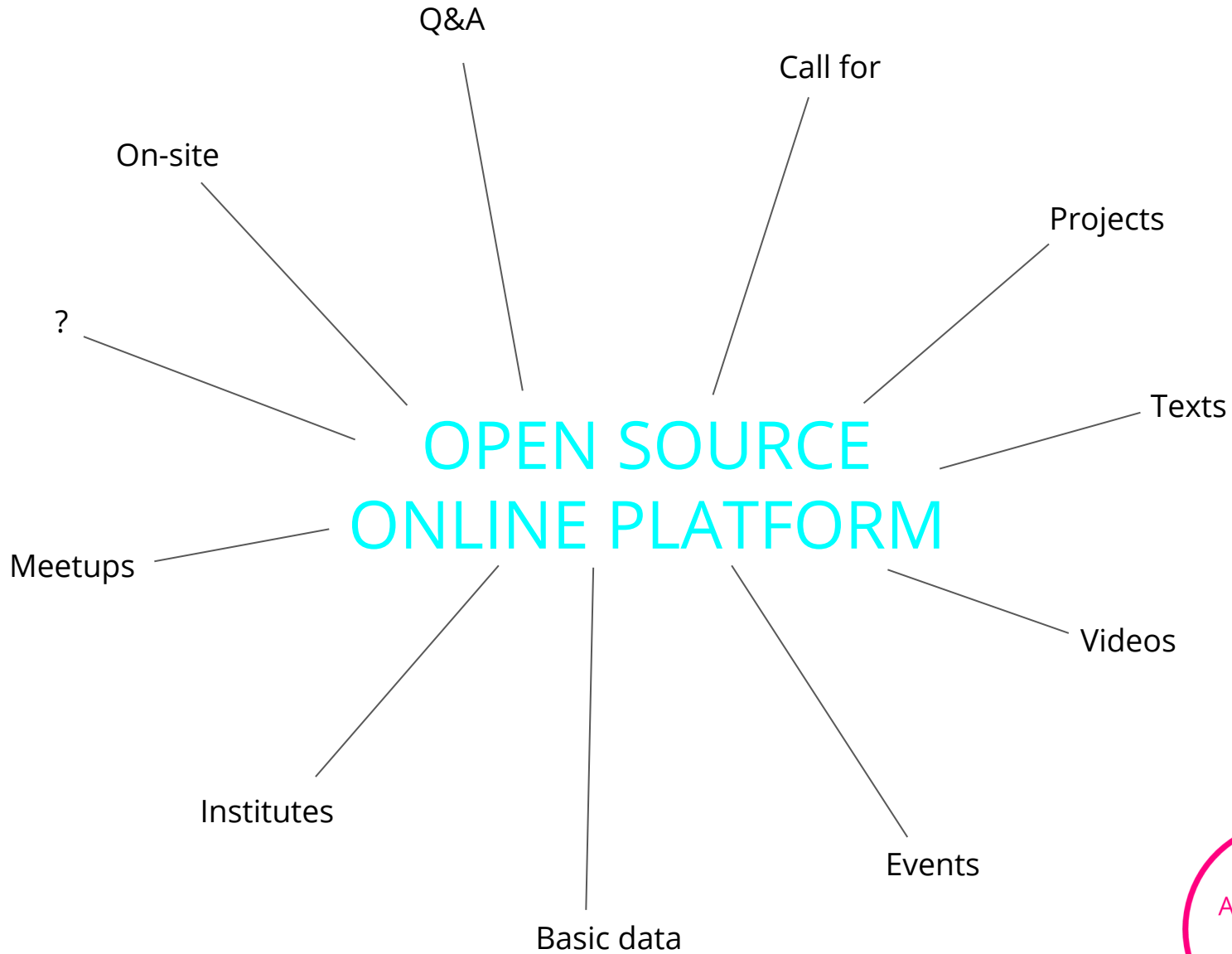

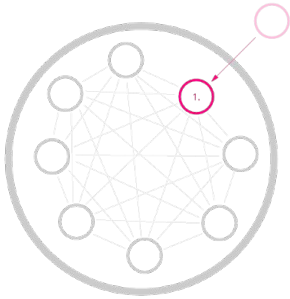

1. INFORMATION

YOU bring information, calls, events to the **PLATFORM**. The information can be **FIRST** or **SECOND HAND**.

INFORMATION such as: **NEEDS, ON-SITE** information, **QUESTIONS** or **ANSWERS, CALL FOR, PROJECTS, TEXTS, VIDEOS, EVENTS, BASIC DATA, ?**

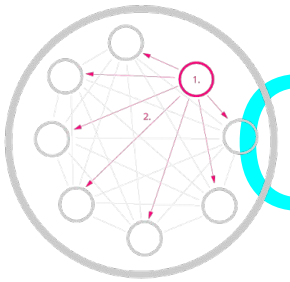

2. PLATFORM

YOU SHARE your information on the **OPEN SOURCE ONLINE PLATFORM**. It is available for everyone. You **TAG** the information you have shared, so it is immediately organised into the main topics.

The platform has a general **POOL** of **INFORMATION** and a specialised **BEST PRACTICES**. Your information and your **KNOWLEDGE, EXPERTISE** is available on the platform for everybody which helps to find **PARTNERS** for further developments.

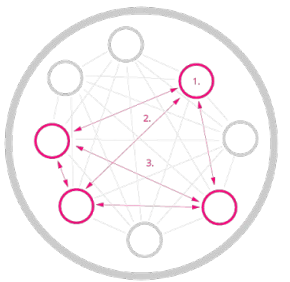

3. MATCHMAKING + COLLABORATION

On the **PLATFORM** everyone can **FIND PARTNERS** for **COLLABORATION**. The platform **CONNECTS** and **EMPOWER** you for **COLLABORATION**.

Collaboration can be on a **GLOBAL SCALE** - virtual or on a **LOCAL SCALE** - physical. The platform organises online and offline, local and global **DISCUSSIONS** and **WORKSHOPS**.

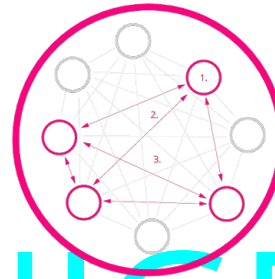

MANAGEMENT - Architecture for Refugees

The Architecture for Refugees **PLATFORM** and **COMMUNITY SUPPORT** projects, ideas and collaborations with information, knowledge, know-how and fundings. We **HELP** with administrative, communicational and financial **ADVICES**.

The **PLATFORM** will also **TAKE ACTIONS** to use the collected knowledge to initiate new projects. We will call for design projects, competitions and fundraising campaigns.

ORGANIGRAM





Architecture for Refugees
Community

Create Call to Action

Like Message

Response rate, 8-min response time

Respond faster to 386 likes +10 comments this week

Henrik Ceccarini and 85 others

Promote

THIS WEEK

1,794 Post Reach

252 Post Engagement

4 of 4 Response Rate

8 minutes Response Time

View Pages Feed

See posts from other Pages

Invite friends to like this Page

Boost Your Page for Free

Reach even more people in your area

Boost Page

ABOUT

Our community aims to join architects, urban planners and designers to create a better built environment for refugees. Join us!

Typically replies within minutes

Message Now

Add your website

Boost Website

PHOTOS

Architecture for Refugees shared a page.

Published by Bence Komlosi · 1 hr ·

We will collaborate in 2016 and 2017 with the Tirana Architecture Weeks!

Tirana Architecture Weeks (TAW)

Education · 4,733 Likes

Like Page

4 people reached

Like Comment Share

Architecture for Refugees shared a page.

Published by Bence Komlosi · 1 hr ·

Copenhagen Architecture Festival will be also our partner in the Future Architecture Platform series! We are very happy to collaborate with them!

COPENHAGEN ARCHITECTURE FESTIVAL CAF

Community · 6,195 Likes

Liked

5 people reached

Like Comment Share

Facebook

PAGE



activists



Twitter

AfR @a4refugees

Photos and videos



Tweets 1 Following 10 Followed 13 Liked 20 Edit profile

AfR @a4refugees · 2h On our Facebook PAGE you can find even more articles, projects, calls, events! Check it, share it and collaborate! facebook.com/Architecture-f...

AfR @a4refugees · 2h Refugees Welcome! #refugees #architecture #a4refugees



Who to follow · Refresh · View all

- bulthaup @bulthaupOnline Followed by Baumeister Follow Promoted
Olly Wainwright @ollywainw... Follow
Make City Festival @Make... Followed by amateur cities ... Follow

Find friends

Trends · Change

- #AshWednesday
#OTWOLTheBreakUp
#pmqs
Adam Johnson
#JuniorDoctorsStrike
#JustinBieberBRITs
YOU ARE BEAUTIFUL SELENA
FOCUS ON ARIANA
To Kill a Mockingbird
Kevin Mitchell



Meetups are neighbors getting together to learn something, do something, share something...

Sign me up! >

Photo: The Dutch Photography Meetup Group

All Meetups within 5 miles of Zürich, CH Groups Calendar

Meetups

Sort by Best match

10 Days of Hiking We're 1,028 Companions

Zürich Machine Learning and Data Science We're 1,668 Machine Learners

Zürich Meets (with Ladies) We're 274 Meets

Zürich Yoga For All We're 374 Friends

Zürich city Badminton We're 200 Shuttle tops

Zürich Entrepreneurs Startups & Investors Group We're 390 Rock Star Entrepreneur

Zürich fun indoor and outdoor Activities We're 6,048 Mitglieder

LetsMeet - Single Network & Events We're 1,369 Singles, Networker

Zürich German Conversation Group We're 1,540 Mitglieder

Language and Culture meetups in Zurich We're 1,302 Langlearners

French Table Zurich We're 1,789 French Speakers

Zürich Happy Runners We're 776 Happy Runners



Q&A

On-site

Call for

Texts

Institutes

Webpage

Projects

Events

?

Videos

Basic data



ABOUT

Zurich
Zürich, Switzerland

http://actionfromswitzerland.ch/

PHOTOS

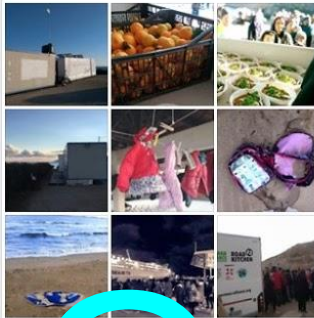

VIDEO



VISITOR POSTS

Tanja Tibaldi
January 22 at 7:50am

I would like to send sleeping bags and such to the "Frontline" in Gr... See More

Like · Comment 1 Comment

LIKED BY THIS PAGE

- terre des hommes schweiz terre des hommes schweiz Like
- magnusboguckl.com Like
- Humans of the Refuge Like

Action from Switzerland added a new photo to the album: **Convoy 5: Chios, Greece.**
February 1 at 8:13am

These are two containers at the "Kiosk" lookout /landing spot on Chios. This is where cold, wet and scared refugees arrive every other day. The winds can be brutal and newly arrived women and children often have to either change in a secluded spot in the cold / at the front seats of volunteers' cars. But for privacy reasons, some don't, so they end up staying in wet clothes, freezing cold, waiting for the bus, sometimes for hours on end.

One of the containers is also where a group of dedicated local heroes rest when they can. They are the ones who have been there right from the start - way before international volunteers arrived, and rescued countless refugees by guiding boats that are in trouble to safe spots. They hardly sleep, always on the alert and spend most of their time living out of one of these containers waiting for boats.

Together with 2 other donors, **Action from Switzerland** pooled together our resources to fit these 2 containers with solar panels to provide electricity / heating. We believe this is a viable long-term, sustainable and green solution. It really was a no-brainer for us.

We are very happy to know that in a week or so, women and children are able to change in private, get warm quickly and the local heroes no longer have to pay exorbitant electricity rates.

Thank you for your trust and generosity in making this happen and please keep donating to sustain our work.

HOW TO DONATE:
 Through Paypal:
 email: paypal@actionfromswitzerland.ch
 Through credit / debit / bank account:
 Account Name: Action from Switzerland
 Address: Küssnacht, 8700
 Account Number: 89-215
 IBAN: CH94 0900 0000 8921 9126 2
 BIC: POFICHBEXXX



Like Comment Share

Architecture for Refugees, Gwendolyn Tan, Diana Dressler, Sylvie Baudry and 38 others like this.

Create Page

- Recent
- 2016
- 2015

On-site



- Select All AWAY
- Mathilde Duvinaige 7:08pm
super, great good luck with them, please let us ...
- Christina Risinger Wed
Thanks, we have already shared that blog too! I...
- Susana Dos Santos Mon
Dear Susana, all these things sounds great! I wi...

Mathilde Duvinaige

FEB 1ST, 11:25AM

Hello, I live in Paris, and I wonder where you are based? Is there any meeting point in Paris?

And do you have projects coming up? I am an architect interested in joining the reflexion and to think about some projects! See you! MATHilde

Dear Mathilde, personally (Bence Komlósi - co-founder) is based in Zürich and Budapest but some meeting sounds great. I was also thinking to do an online meeting! We would fix a date on facebook and could share ideas, thoughts, ...

I think it would be also interesting to organise local events dealing with the topic. I would suggest you to join a public group and ask if there is anyone who would like to have a Paris meeting. I can also post it on the facebook page.

There is no exact project, but there are some conditions, dealing with the topic. The Architecture for Refugees would like to have a group online where you and me can share ideas, questions, ...

Please write these questions on the facebook page.

Have a lovely Monday.

Best,
Bence Komlósi

Sent by Bence Komlosi (?)

FEB 1ST, 3:22PM

Okay thank you for your answer Bence & really nice to meet you 😊. I'm not sure to have enough time and energy to carry a project these days, but I'm really interested in the subject and I know other people that do some things in other activities domains for and with the refugees, so I think architects (and I mean myself as well!) should also think about the problematic and experiment things ..? That's why I wanted to join the group, but I don't have for the moment any precised project I have to reflect on the subject ! But maybe a meeting with debates could be interested..?

and I should read the posts of the page. Their seems to have a lot of interesting things to read!

FEB 1ST, 4:39PM



Mathilde Duvinaige

About View Profile

Liked since Feb 01, 2016

Keywords Add keywords to help manage your conversations. Only admins can see keywords. Enter a keyword...

Your Notes Add Notes Notes help you keep track of your conversations. Only admins can see notes.

Relationship FEBRUARY 01, 2016 Liked your Page.

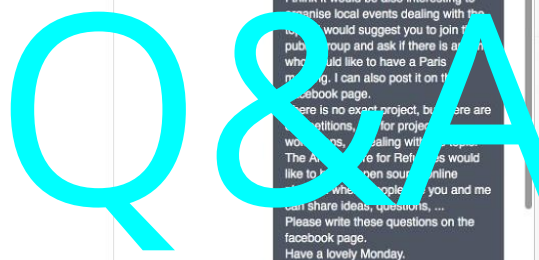



Engaging Post

Architecture for Refugees with Pieter Billiet.
Published by Bence Komlosi · February 8 at 3:58pm ·

Call for Collaboration by Pieter Billiet!
Brainstorming / design / building / funding!

Pieter Billiet
Today at 3:50pm

HI THERE I'm an architecture student from Belgium, currently working on my master's thesis. My main case study is the refugee crisis in Calais and Dunkirk and I have been actively helping out with building in the jungle for the past 2 months. Now that the second semester has started I plan on working out several small (or big) scale building projects that could be built on the camping sites. As this is a rather ambitious project to do by myself I was wondering if anybody on this page would be interested in helping me out on these projects ? (thinking about them, designing them, building them, funding them, ...) Let me know if anyone is interested ! All the best, Pieter

Unlike · Comment · 1 Like

295 people reached

Boost Post

Like · Comment · Share

Mounir Hathout, Louis Savary and Bence Komlosi liked this. Chronological

Bence Komlosi Great Initiative Pieter Billiet!
Like · Reply · Message · February 8 at 4:06pm · Edited

Bence Komlosi Luca Lucas and Pieter Billiet do you know each other? Luca Lucas was also in Calais! Let me know if you know each other. Pieter Billiet maybe Luca Lucas can help you with contacts, ...! Have a nice day!
Like · Reply · Message · 8 hrs

Write a comment...

SPONSORED Create Ad



iStock Credit Packs
istock.com
Whatever content you need, get it with iStock credits.



Höhere Dichte ertragbar?
baueundgesellschaft.ch
2. Fachtagung Bauen und Gesellschaft auf Messen Areal. Jetzt Anmelden.



CatalyticAction Designs Playgrounds for Refugee Children in Bar Elias, Lebanon

06:00 - 8 December, 2015 | by [José Tomás Franco](#)

[Save this article](#)

[Log In](#) [Tweet](#) [Pin it](#)



"Within humanitarian responses, programmatically, children often become invisible." (Marc Sommers)

The Syrian crisis has forced thousands of families to leave their homes in search of safe places to continue with their lives. Many families have moved to Lebanon, where the UN has raised a series of informal settlements. While effective in providing shelter, they don't provide specific solutions for children, many of whom have had their studies interrupted and don't have public spaces equipped to play sports and interact with other kids.

In response to this situation, the architects of [CatalyticAction](#) have designed and built a playground in one of the schools developed by The Kayany Foundation and American University of Beirut's Center for Civic Engagement and [Community Service](#), involving children throughout the entire process and allowing the structure to be easily disassembled, transported and either reassembled or repurposed.

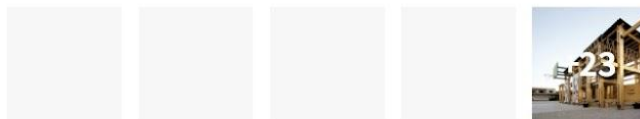

Description from the Architects: The Syrian crisis is the world's largest refugee crisis for almost a quarter of a century under UNCHR's mandate (UNHCR, July 2015). It has devastated lives; uprooting families from their homes and forcing them to leave the country to find safety elsewhere. The conflict



MORE SUSTAINABILITY

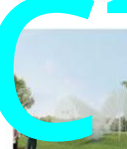

Pavilion Made Out of Recycled Coat Hangers Constructed on Governors Island
[Architecture News](#)



William McDonough Unveils ICEhouse™, The Next Step in the Circular Economy
[Architecture News](#)



In 4 Days, 100 Volunteers Used Mud and Reeds To Build This Community Center in Mexico
[Misc](#)

[More Sustainability >](#)

MORE MISC



University of Miami Hosts Sustainability Workshop for High School Students
[Misc](#)



Beyond the Tent: Why Refugee Camps Need Architects (Now More than Ever)

09:30 - 14 October, 2013 | by Katherine Allen

Save this article

Log In [Tweet](#) [Pin it](#)



In 2013 alone some 1 million people have poured out of Syria to escape a civil conflict that has been raging for over two years. The total number of Syrian refugees is well over 2 million, an unprecedented number and a disturbing reality that has put the host countries under immense infrastructural strain.

Host countries at least have a protocol they can follow, however. UN Handbooks are consulted and used to inform an appropriate approach to camp planning issues. Land is negotiated for and a grid layout is set. The method, while general, is meticulous – adequate for an issue with an expiration date.

Or at least it would be if the issue were, in fact, temporary.



OPEN CALL

SUBMIT YOUR ARCHITECTURE VALENTINE'S DAY CARD

We'll publish the winners!
All entries must be received by
February 11, 12pm EST.

[CLICK TO PARTICIPATE »](#)

MORE ARTICLES

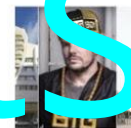

AD Readers Debate: #VoIsMore, NCARB Scraps "Intern," and More
Articles



Gallery: Public Auditorium in Llinars del Vallès by Alvaro Siza + Aresta Arquitectura
Articles



Lacaton & Vassal and KieranTimberlake Named Among Metropolis Magazine's 2016 "Game Changers"
Articles

[More Articles »](#)

MOST VISITED



The Story Behind The Most Creative Job Application We've Ever Seen
Architecture News





IBTASEM - A playground as a response to the refugee crisis

Catalytic Action
Subscribed 5

1,021

Add to Share More

11 0

Published on Dec 11, 2015
In August 2015, CatalyticAction completed the pilot playground project 'IBTASEM' as emergency response to the Syrian refugee crisis in Lebanon. The pilot project acts as a catalyst by triggering the awareness for a much-needed space for these children in a time of crisis.

SHOW MORE

ALL COMMENTS

Add a public comment...

No comments to display

Up next Autoplay

- Schooling of Syrian refugees children in Lebanon**
Women's WorldWide Web (W4.org)
243 views
- Refugee Children perform during the Ibtasem Playground Inauguration in Bekaa**
American University of Beirut
49 views
- More than a playground for Syrian refugees in Jordan**
Mercy Corps
1,070 views
- IBTASEM * SMILE: A Playground for Syrian Refugee Children in Lebanon**
Catalytic Action
1,754 views
- Busfabriken Playground Fun for Kids (really long edit)**
Family Playlab
17,544,010 views
- FUNNY PLAYGROUND ACCIDENTS AFV America's Funniest Home Videos**
giggs11amazing
3,304,678 views
- Playground Fails Compilation || FailArmy**
FailArmy
5,811,215 views
- Accessing Education: Language Integration for Syrian Refugee Children**
British Council Lebanon
1,216 views
- 3D Indoor Playground Tunnel for Kids to LEARN COLORS Fun Cool Surprise Eggs**
DuckDuckKidsTV [Duck Duck Kids TV]
14,416,051 views
- Playground FAILS**
2M Media
169,627 views
- Drawing smiles on the faces of Syrian refugee children in Turkey**
UNICEFmena
2,956 views
- Ultimate Playground Fails Compilation // FailArmy**
FailArmy
5,111,154 views
- RECESS WITH LIZZAZZA / Playground Memories | Lizzaza**
Liza Koshy
966,512 views
- Small Kids Playground Fun + Videos for Babies to Watch - Ingrid Surprise**
INGRID SURPRISE
3,891,181 views
- TODDLER PLAYGROUND TAKEOVER!**
Daily Bumps
453,388 views



Architecture for Refugees
Edit Profile

MY EVENTS

- 10 Upcoming
- Subscribed
- Past
- Create



SOCIAL DESIGN

Elevation Days

20 FEB Social Design Elevation Days 2016 Impact Hub Munich
20.-24. Februar 2016

Public - Hosted by Hans Sauer Stiftung Share

February 20 - February 24
Feb 20 at 7 PM to Feb 24 at 10 PM

GUESTS

99	42	32
interested	going	invited

Impact Hub Munich
Göttinger Strasse 8, 81371 Munich, Germany Show Map

Die Social Design Elevation Days beschäftigen sich in diesem Jahr mit dem Thema Home Not Shelter! Fünf Studierendengruppen der Universitäten Berlin, München, Hannover und Wien sowie der Hochschule in Oldenburg haben sich bereits ein Semester lang mit diesem Thema beschäftigt und spannende Entwürfe erarbeitet.

>> Am 20.02.2016 um 19.00 Uhr in München die Möglichkeit die einzelnen Projekte kennen zu lernen! Ab 22:00 Uhr feiern wir den Auftakt gemeinsam mit einem Get Together im Provisorium.

Der 21.02.2016 der Exkursionstag. Wir nehmen 20 Studenten. Um 11:00 Uhr besuchen sie in fachkundiger Begleitung zwei Unterkünfte in München. Um 18:00 Uhr kochen wir gemeinsam mit Kitchen on the Run unser... [See More](#)

Events

POSTS

[Write Post](#) [Add Photo / Video](#) [Create Poll](#)

Write something...

RECENT ACTIVITY

Hans Sauer Stiftung
February 8 at 2:21pm · Public

Mehr Informationen zum Projekt Home not Shelter! finden Sie auf unserem Blog: <http://homenotshelter.com/>

Home not Shelter! Gemeinsam leben statt getrennt wohnen.

Home not Shelter! – Gemeinsam leben statt getrennt wohnen ist eine Hochschulübergreifende Initiative zur Schaffung von integrativen Wohnlösungen...

HOMENOTSHELTER.COM

Like Comment Share





There are millions of people in refugee camps around the Middle East.

Some countries have accepted those from neighbouring nations who are fleeing war and conflict.

But now, the King of Jordan - a country that borders Iraq and Syria - says it's at "boiling point" after allowing 635,000 refugees from Syria.

He says if countries from around the world want Jordan to continue helping refugees then they'll need a lot more help.

There are more people claiming refuge in Jordan, Lebanon and Turkey than anywhere else, including Europe.

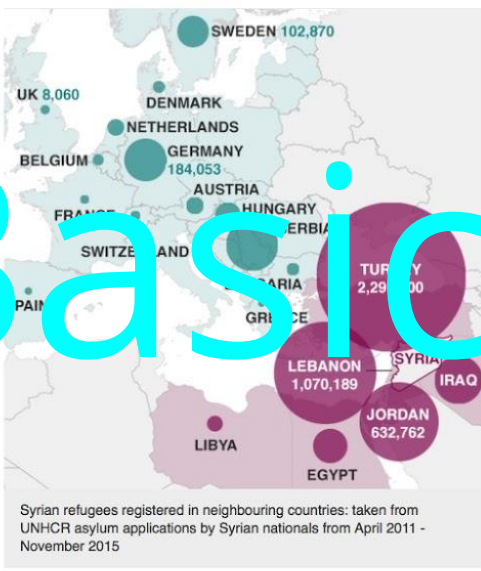

Jordan



Most Popular



1 Students 'sex rating' females on Facebook
LIFE 2h



2 Home needed for one rabbit in Glasgow
YOU WHAT? 1d



3 WWE superstar Daniel Bryan retires
ENTERTAINMENT 1d



4 Greg James starts Gregathlon challenge
SPORT 2d



Basic data





Sustainable Emergency Architecture
College & University

Sign Up Liked Share

Timeline About Photos Reviews More

5,060 people like this
5.0 of 5 stars · 2 reviews
View Reviews
Invite friends to like this Page

Status Photo / Video
Write something on this Page...

ABOUT
Calle Imm...ada 22
Barcelona, Spain
Ask for Sustainable Emergency Architecture's phone
<http://www.uic.es/en/international-cooperation>

Sustainable Emergency Architecture added an event.



23 FEB Live Information Session 2016
Tue 4 PM · Sustainable Emergency Architecture · Barcelona, Spain
1 guest
Like Comment Share

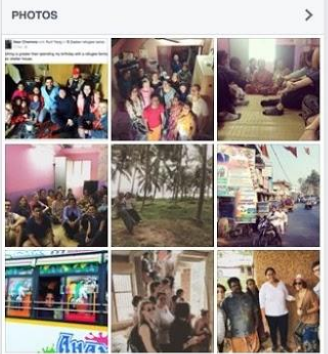

Raquel Colacios and Viviana Diaz like this.
Write a comment...

Sustainable Emergency Architecture
4 hrs · Barcelona, Spain

Poverty is also a problem in the developed world. This week in our joint Mundus Urbano urban workshop, our group has been working with students from the four universities of the consortium in assisting the Banc dels Aliments of Barcelona in their current efforts to improve the logistics and quality of its operations in response to the needs of the city's poorest residents who are still suffering grave side-effects of the economic crisis in Spain. If you're in Barcelona, you can see them present their analysis and proposals at UIC Barcelona, in front of a jury of experts from the field, including Red Cross.



Create Page

Recent
2016
2015
2014
2013
2012
2011
2010

Institutes





Architecture
for
Humanity

Facebook

Wikipedia

Calaid-ikipedia

EXAMPLES

Archinect

Wikihouse

Uber

Architecture
Sans
Frontier





- Editorial & News
- Employment
- Community
- Academia
- About
- Login / Join

series architecture life art sztaki dict bib drive dotlinearchitects community kozossegeben_eini mome_dia eth_cohousing mas_communication research job! afr_to_post

Architecture 7 days, The architecture of data forensics 8 days, Full Metal Jacket 8 days, architectural designer 9 days, Senior Architect 8 days, Architectural Designer 9 days, Intermediate Architectural CAD drafting... 10 days, SCI-Arc launches "MEAT," a curatorial... 10 days, Intermediate Residential Designer/Architect 10 days, Architectural Designer/Drafter CAD drafting... 10 days

KOVAC KOVAC Jobs, Intermediate Designer Staff 1 10 days, Project Designer 10 days, Excavating ancient Rome beneath London's... 10 days, Junior Landscape Architect/Designer 10 days, Tenure-Track/Full-Time Tenured Professors 10 days, Project Architect 10 days, Project Manager 10 days, Unfolding dumping design with Architecture... 10 days, Frank Gehry is the first architect to be... 10 days, Marketing Coordinator 10 days

SNØHETTA Jobs, **MARTINEZ+JOHNSON ARCHITECTURE** Jobs, **MARTINEZ+JOHNSON ARCHITECTURE** Jobs, **THE COOPER UNION** Jobs, **KH&S** Jobs, **SF Jones** Jobs

Get Lected: Kent State University CUDC... 10 days, Take a look at "Real Fantasies," AMO's... 10 days, Frank Gehry and Maya Lin find their... 10 days, Folding Light (An interactive light... 11 days, Assistant Project Manager/Junior Architect 10 days, Glen Small gets podcasted by the Urban... 10 days, Sr. CAD Draftsperson 10 days, London's V&A to host a robot construction... 11 days, The architect's guide to doing taxes 11 days, Project Manager/Architect 11 days

Does Houston's architecture lack poetry? 11 days, Zaha Hadid wins the ranks of RIBA Gold 11 days, Get Lected: University of Virginia... 11 days, Glob... 11 days, Existing... 12 days, For Alvar... 11 days, Intermediate Architectural... 11 days, Before + after photos of Syria's devastated... 11 days, Hyperloop, but for New York City's trash 11 days

PR+ Jobs, Senior Designer- DC Office 11 days, China may dam its only free-flowing river... 11 days, Architect / Designer 11 days, Billing Coordinator 11 days, "Practice Sessions" a way for students to... 11 days, Solidworks 3D CAD Drafter, Design Engineer... 11 days, NJ Residents Only " Free CAD , Revit & 3D... 11 days, Australian architects mourn the loss of... 12 days, Planning War Zone: The Battle for L.A. 12 days, 5278 Planner II 12 days

tet Jobs, Interior Architect/Designer- Healthcare 12 days, Project Architect/Manager 12 days, Get Lected: USC, Spring '16 12 days, Intern/Project Architect, 5-10 Years... 12 days, This app will make decorating a whole lot... 12 days, Taking your pad for a spin: Dubai's... 12 days, Mindscraper: high-rise educational facility... 12 days, "Charles and Ray Eames, meet Freddy... 12 days, Watch SANAA's "River" project come to life... 12 days, A tunnel worth travelling: constructing... 12 days

S&A Jobs, Urban & Traditional Design Architect 12 days, Bonus Session: "Scenes from the... 12 days, Crestline 13 days, Riviera 13 days, From the archives: George Nakashima in... 13 days, Another study warns that 3D-printers pose... 13 days, I-M-M-E-D-I-A-C-Y (with collage) 15 days, Architectural CAD Designer 13 days, Mid-level Interior Designer/Architect 13 days, Architecture for + with + by Refugees 13 days

EXAMPLE



Architecture
for + with + by
Refugees

PROPOSAL

WHO WE ARE

The "Architecture for Refugees" aims to be an open platform for architects, urban planners and designers to join their forces for a better built environment for refugees. This Page is the first step but we are open for any suggestions! Join us and let's work together! Should we start a group, is it a better way of being an open platform?



Architecture
for + with + by
Refugees

The "Architecture for Refugees" aims to be an open platform for architects, urban planners and designers to join their forces for a better built environment for refugees. This Page is the first step but we are open for any suggestions! Join us and let's work together! Should we start a group, is it a better way of being an open platform?



[READ MORE >>](#)



ACTION FROM SWITZERLAND

These are two containers at the "Kioski" outdoor/landing kiosks. This is where cold, wet and tired refugees arrive every other day. The winds can be brutal and...

[READ MORE >>](#)

🕒 September 28 💬 16



QUESTIONS AND ANSWERS

There are millions of people in refugee camps in the Middle East. Some countries have accepted those from neighbouring nations who are fleeing violence and...

[READ MORE >>](#)

🕒 September 28 💬 16

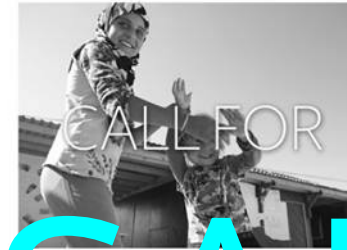

RAINSTORMING/DESIGN BUILDING

You probably have many friends and colleagues who are also architects. Maybe you are also interested in the refugee architecture! Please share your...

[READ MORE >>](#)

🕒 September 28 💬 16

PROPOSAL



PLAYGROUNDS FOR REFUGEE CHILDREN

The Syrian crisis has forced thousands of families to leave their homes in search of safe places to continue with their lives. Many families have moved to Lebanon...

[READ MORE >>](#)

🕒 September 28 💬 16



WHY REFUGEE CAMPS NEED ARCHITECTS

In 2013 alone some 1 million people have poured out of Syria to escape a civil conflict that has been raging for over two years. The total number of Syrian refugees is well...

[READ MORE >>](#)

🕒 September 28 💬 16



A PLAYGROUND TO THE REFUGEE CRISIS

If you need help, please visit our Help Center. There you'll find answers to many common questions about creating an account, watching and uploading videos, and...

[READ MORE >>](#)

🕒 September 28 💬 16



Deutsches Architekturmuseum to Curate German Pavilion at 2016 Venice Biennale

14:16 - 7 December, 2015 | by Karissa Rosenfield

Save this article

Like 297 Tweet Pin it



Deutsches Architekturmuseum (DAM) has been chosen to represent Germany at Venice Biennale 2016 with the exhibition *Making Heimat. Germany, Arrival Country*. The DAM team - including general commissioner and director Peter Cachola Schmal, curator Oliver Elser, and project coordinator Anna Scheuermann - has already begun to collect examples of buildings that are being transformed for refugees and migrants - from large reception centers to refugee-led bicycle workshops. All work will be presented to the public in early 2016 as "an information pool for planners and policy-makers."

"The current refugee situation is part of a massive worldwide flow of migrants. It leads people from the countryside into cities," says the team. "What are the challenges facing cities with incoming refugees and migrants? Where in Germany are the preferred 'arrival cities' located? How do newcomers become socially integrated citizens? And how can architecture and urban design contribute to this process? Taking as a starting point the hypotheses put forward by the Canadian journalist Doug Saunders in his best selling non-fiction book 'Arrival City', the DAM team, with Saunders as advisor, examines these questions in the exhibition 'Making Heimat' in the German Pavilion. How, in the future, can Germany's "arrival cities", such as Offenbach am Main respond and hypothetically shape the conditions that create a good 'Arrival City'?"

Exhibition and catalogue design will be executed by the Berlin practice Something Fantastic.

Save this article

Like 297 Tweet Pin it

MORE ARCHITECTURE NEWS

Monocle 24's 'The Urbanist' Discusses Heritage in Tunis, Vienna and London
Architecture News

Guto Requena's "I AM" Installation Lights Up Paulista Avenue with People's Emotions
Architecture News

4 Architecturally Inspired Jewelry Lines
Architecture News

More Architecture News »

The Best Submissions to Our Valentine's Day Contest
Architecture News

A 6000-Year Old Unplanned Community Photographed From Above
Misc

15 Incredible Architectural Feats Made in Minecraft
Articles

MOST VISITED PRODUCTS

Wood - Accoya Wood for Cladding | Accoya
Wood / Bamboo





Places for People

PLACES FOR PEOPLE



15. Mostra Internazionale di Architettura
15th International Architecture Exhibition
La Biennale di Venezia
2016
Austrian Pavilion

Places for People

Due to the refugee crisis, this contribution to the 2016 Architecture Biennale is not limited to the pavilion in Venice but also includes three ongoing projects in Vienna.

More concretely, these teams have been commissioned to work together with NGOs not only to design the conversion of empty buildings into temporary accommodation for people whose asylum claims are being processed but also to accompany these buildings in the longer term.

The objectives of these interventions are to subject the social responsibility of architecture to a reality check, to provide humane places to live for those affected and to present the results in Venice to a broader public.

FUTURE

Places for People

EVERYONE HAS THE RIGHT TO SEEK A SAFE PLACE TO LIVE.*

15th International Architecture Exhibition La Biennale di Venezia 2016

Austrian Pavilion

Contact Press





After Belonging In Residence On Residence
Utvidet program Nyheter og presse Kalender

OAT 2016
OM OAT
KONTAKT
ENGLISH



Velkommen til OAT 2016

Vinnerne av In Residence-utlysningen er klare

AKTUELT



In Residence-programmet: Nye strategier for Åfter Bølonnging



On Residence-programmet: Definerer Åfter Bølonnging



Utvidet program



Nyheter og presse



In Residence-stedene



In Residence-reportere



Jury for In Residence-utlysningen



Facebook

Meetup

Webpage

NEXT STEPS

Partners

Promotion

Funding

Twitter



The Culture of Care

by Sally Weintrobe

THE CULTURE

OF CARE

“Actively breaking the loving link makes us feel less guilty. It creates the culture of un-care.”

Architecture
for + with + by
Refugees

CALL FOR COLLABORATION!

Architecture
for + with + by
Refugees

