

PROXIMA UTOPIA

PROXIMA

UTOPIA

Future Architecture Platform 2017

Museum of Architecture and
Design (MAO), Ljubljana

Selim Projects (Helsinki)

Mika Savela & Henrik Drufva

UTOPIA

PROXIMA

UTOPIA PROXIMA

PROXIMA

UTOPIA

WHAT IS THE future
STATE OF UTOPIAS?

DO THEY REFLECT THE
current/past
STATE OF THE WORLD?

UTOPIA

PROXIMA

FUTURE

PAST

HOW ABOUT TOMORROW:

No sooner does any American settle himself down contentedly with the idea that life in America has been pretty darned good lately than he is tormented by a question: "What will it be doing for us later than lately?"

The future he and his children will know, the America of 1975, has already been charted and predictions are being made. To get a picture of tomorrow's good life, *LIFE* consulted city planners, economists, businessmen preparing for the next decade's consumer goods and architects

whose success will depend on figuring how the four million Americans born every year will live. Their optimistic prophecies are shown on these following pages—along with some sobering misgivings (p. 172).

Housing will still be crucial in 1975. But most architects agree that with proper planning and imaginative building, the next 15 years should bring the beginning of the end not only for the grimy apartments and grim tenements of America's congested cities but also for the one-family



MASS HOUSING IN THE CITY

An architect's conception of city housing in 1975 shows a landscaped 20-acre park, with 30-story apartment buildings, playing areas and swimming pools.

Cutaway view shows one-family duplex built around a large private balcony. It gives each member of family his own bedroom-living room unit to insure increased space and privacy needed when most Americans will have much more spare time for projects and hobbies. Here father paints (left) as son (above)

A PRACTICAL PROPHECY

home on the small suburban parcel of land. Replacing them all as basic mass housing of the future, according to New York Architect William Ballard, of Ballard, Todd & Snibbe, who designed the drawing of it below, will be something called "The Tower in the Park." Six of these modern towers, each 30 stories high with duplex apartments for 720 families (about 3,000 people), will be built in a 20-acre park. Starting at the very edge of any city's business section, a series of these units would extend

across what are today city residential areas and on through the suburbs.

Ballard estimates a town of 12,000 people could be housed in towers on just 80 acres (an average suburb of 12,000 population uses 1,800 acres) and include more play areas than any housing development. By freeing the suburban householder from the chores of do-it-yourself home upkeep, the towers will give a family more time to enjoy the assortment of worldly goods and selected services ready for them (turn the page).



How does science homework in room with small private laboratory. Sisters (below balcony) play duet. Kitchen (background left) has thermoelectric cabinet—freezer and oven combined—for keeping and quick-cooking prepared food. On balcony, mother cooks outdoor meal on thermoelectric hotplate.

Architect estimates that the apartment would sell for same price as an average suburban home. In the distance tenement buildings are being demolished by a crane and beyond that are skyscrapers of city downtown business section, near enough so apartment dwellers can get to work easily and quickly.

MODERNITY

AS adaptation to change

HELLO
WORLD



HELLO
WORLD

BLEAK / BRIGHT
FUTURE?

AFFROFUTURE



HELLO
WORLD



HELLO
WORLD

PSEUDOFUTURE

NOVA TOTIVS TERRARVM ORBIS GEOGRAPHICA AC HYDROGRAPHICA TABVLA. Auct. Henr. Hondio.

MAPPA MONDI

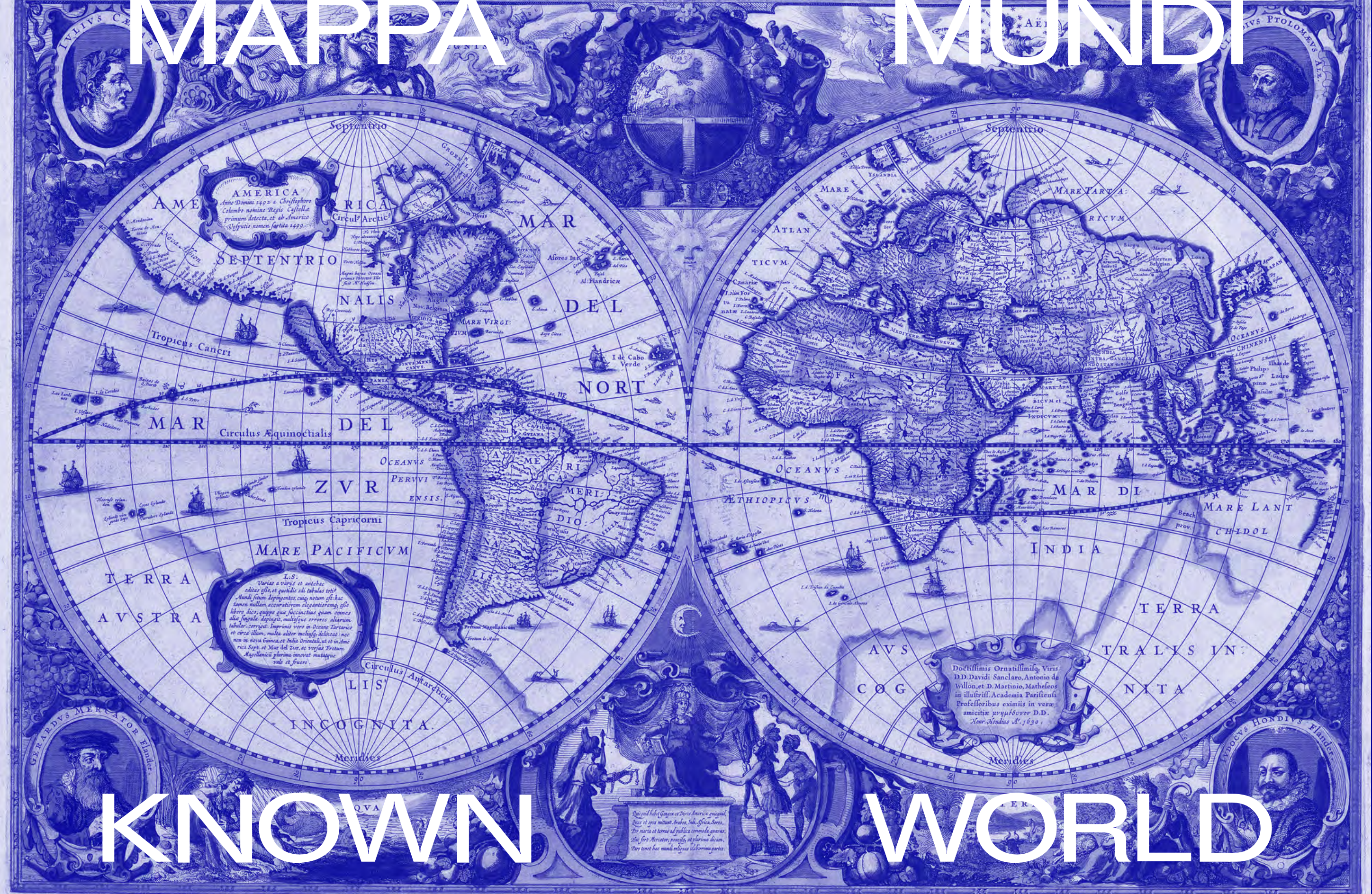

HELLO

WORLD

KNOWN

WORLD

CABINET ATLAS

AND

DESCRIPTIVE GEOGRAPHY.



HELLO

WORLD

ATLAS

WARBURG



Panel C
 Developments in the representation of Mars.
 Detachment from the anthropomorphizing conception image—harmonic system—sign

FOR



Städte / Cities
 1968 66.7 cm x 51.7 cm Atlas Sheet: 118

RICHTER

FUTURE?



RATIONALIZING

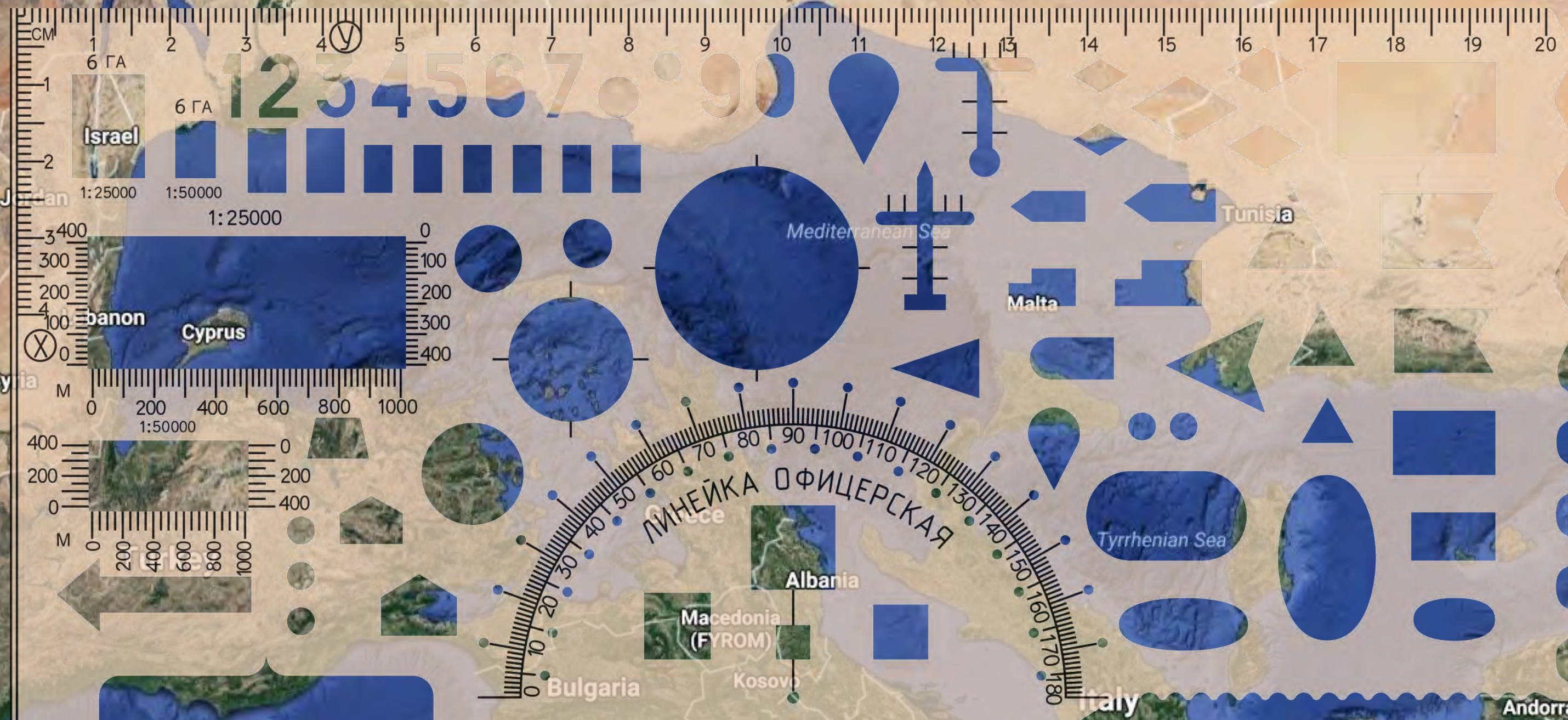

FUTURIZING



FUTURE

PROXIMA

LIST OF MAPS AND PLANS

UTOPIA

UTOPIA



PROXIMA

ATLAS

PROXIMA

UTOPIA

FUTURE

ATLAS

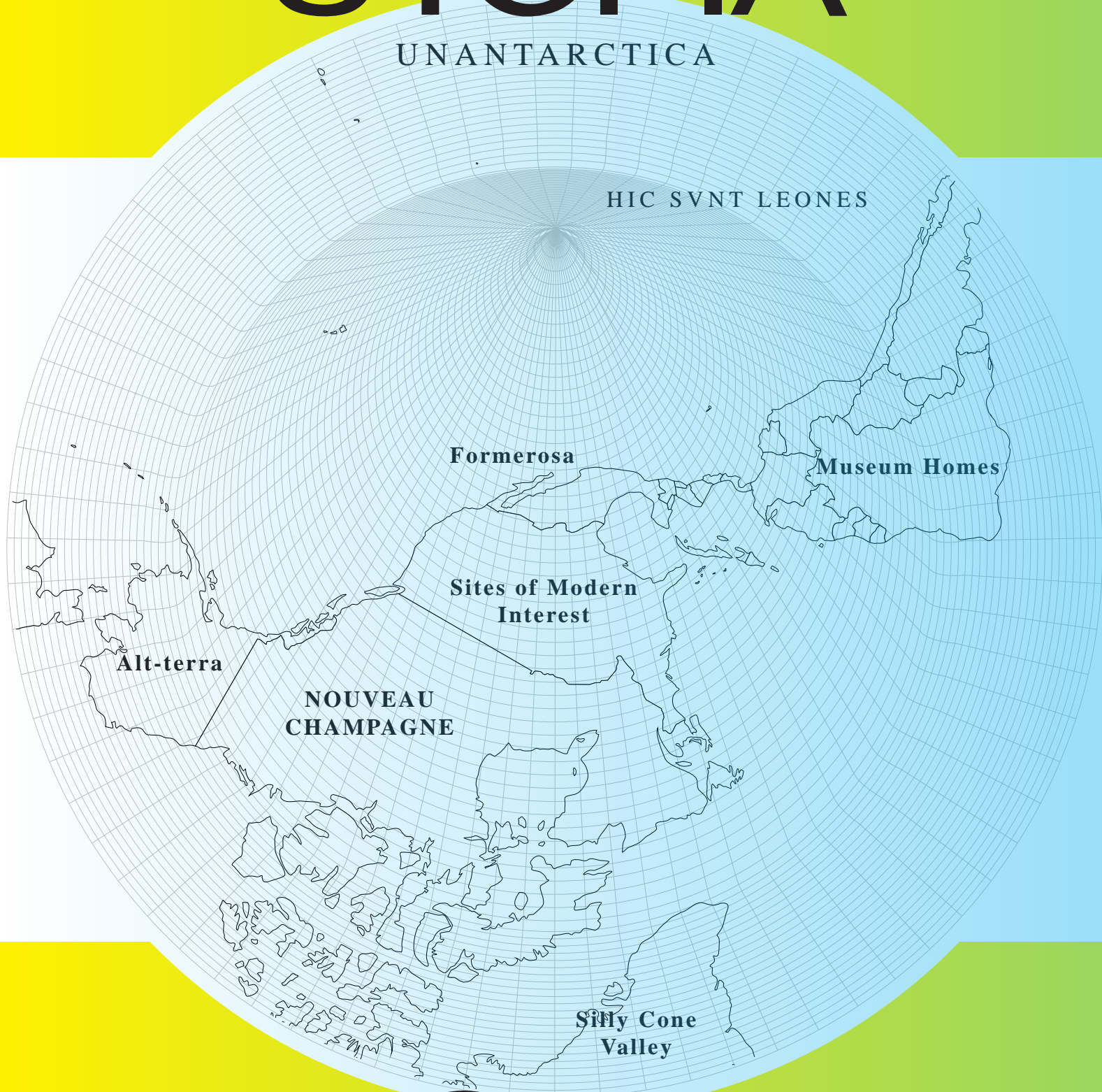
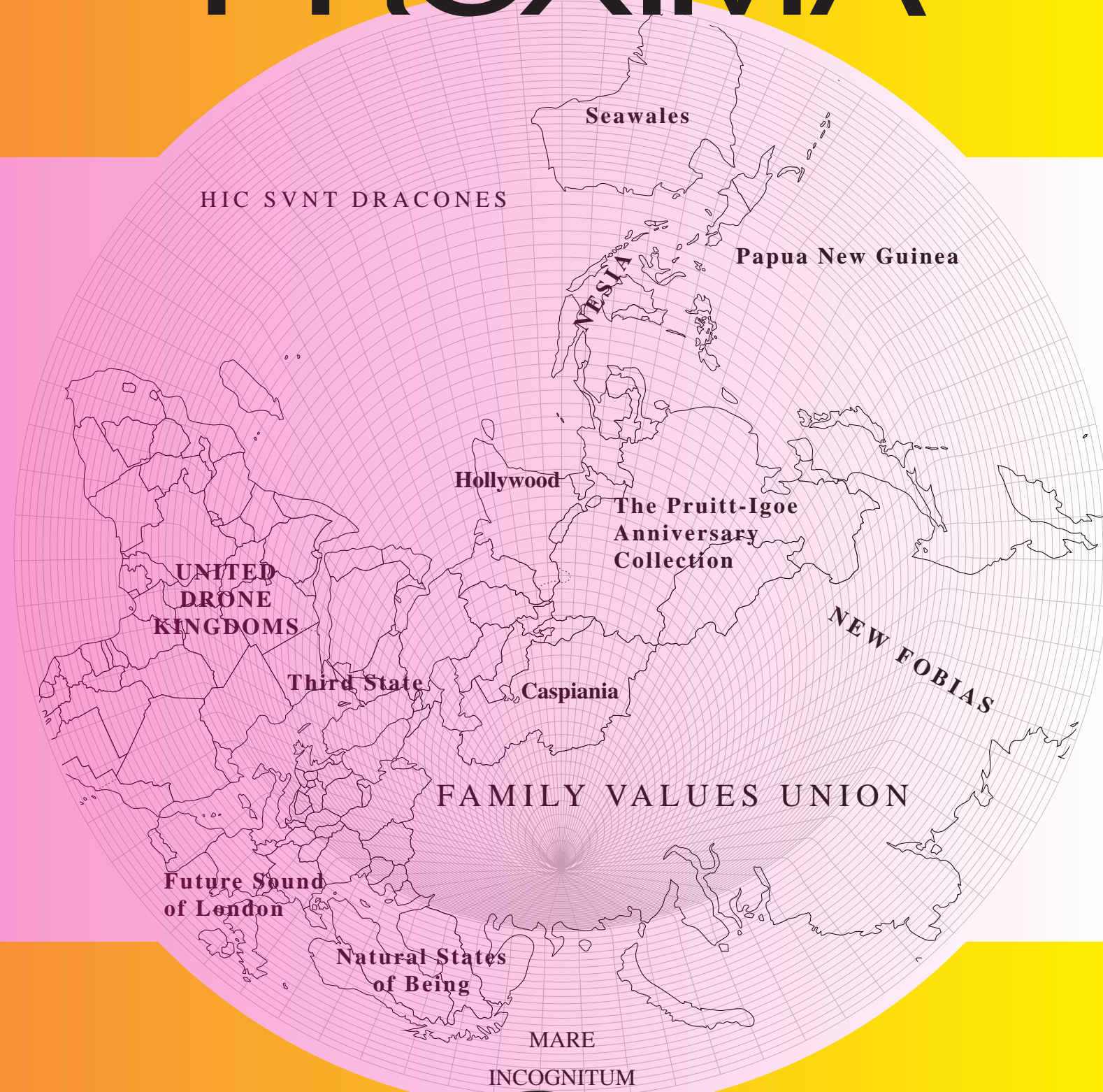

UTOPIA

PROXIMA



NO

NEW

FUTURE

ATLAS

past

now

now

invests

predictions

the

who

in

about

totally

talks

future

future

another

about

most

NEW

NOW

SEA MONSTER



HIC SVNT DRACONES

HIC SVNT LEONES

FUTURE

ATLAS

MONSTER SEA

THE

SILLY

FUTURE

ATLAS

CONE

VALLEY

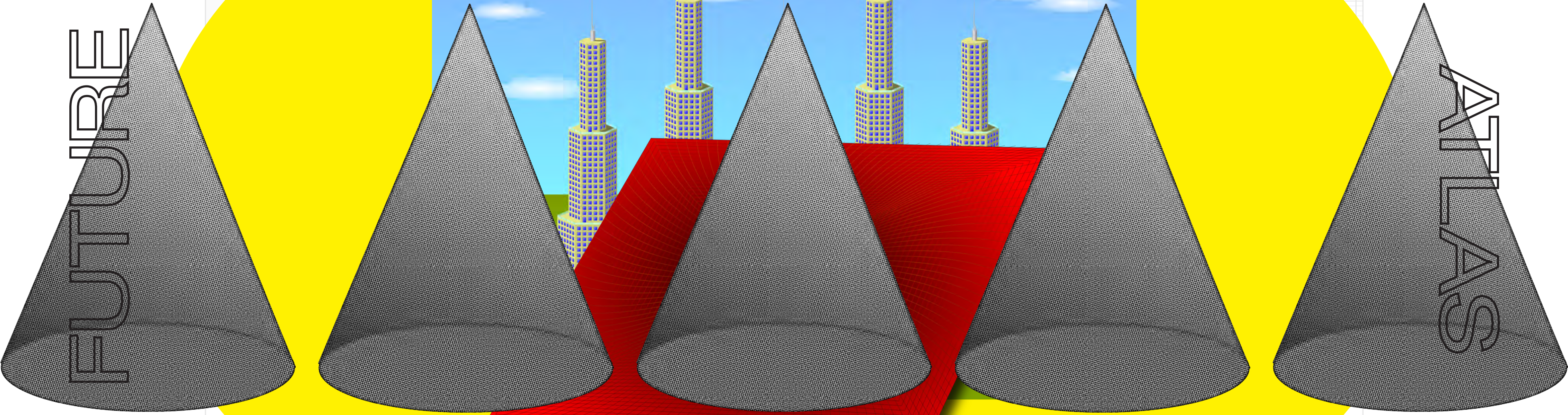

Parking Spaces
 Level 02: 9129 Spaces
 1078 Standard Parking spaces (9'-5")
 1000 Compact Parking spaces (8'-6")
 82 Accessible Parking spaces (8'-6")

01 Basement Level 2
 Year

Apple Inc.
 Apple Campus 2
 Proposed Main Building
 Basement Level 2
 Plan
 1856 08/08/11 11:44
 P-8.08 04

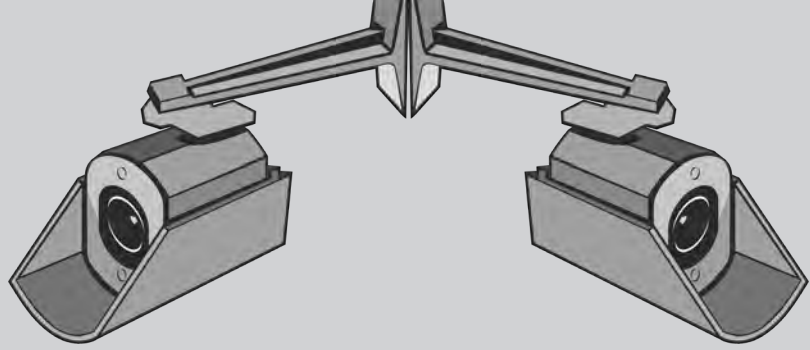

THE

FAMILY

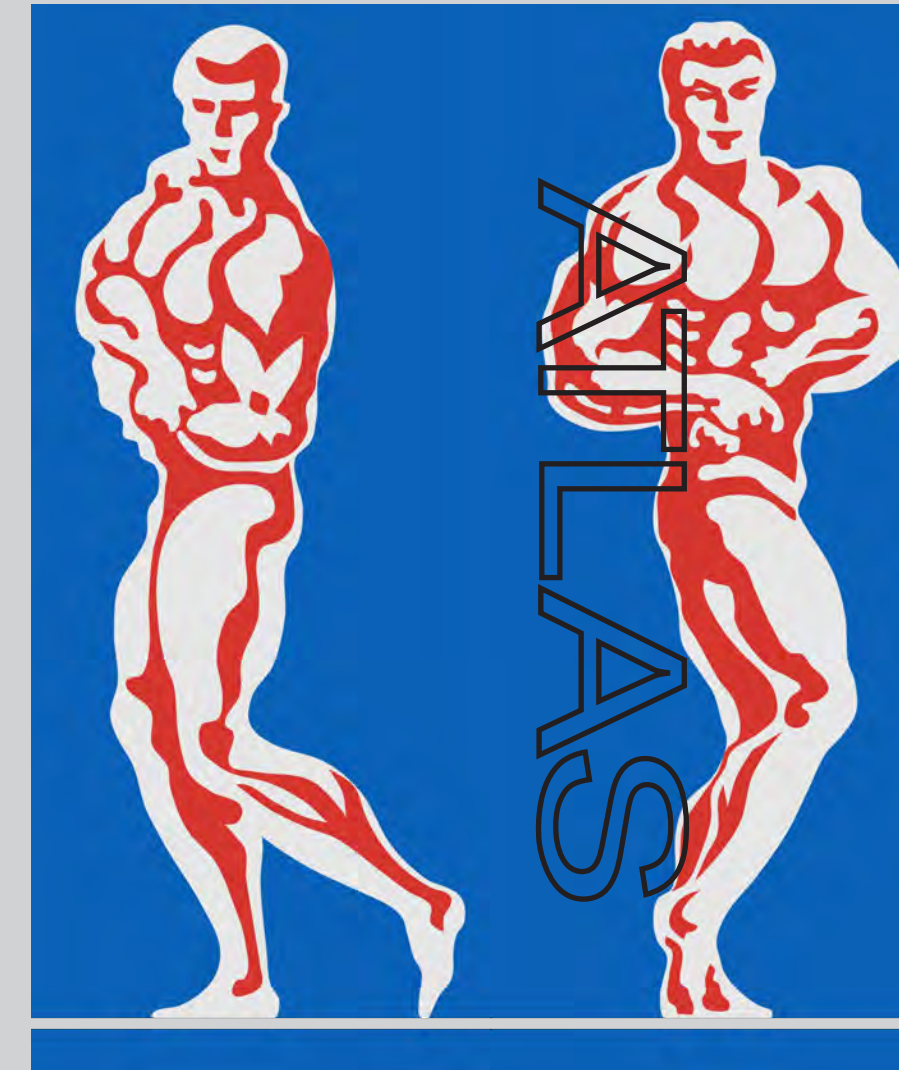
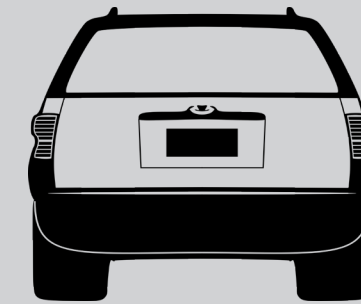
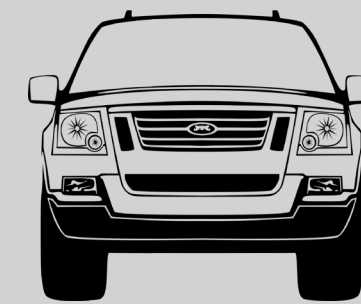
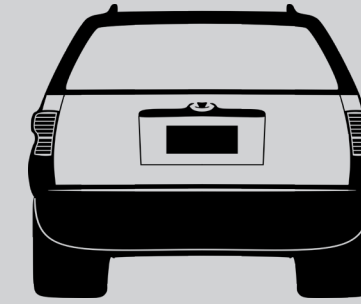
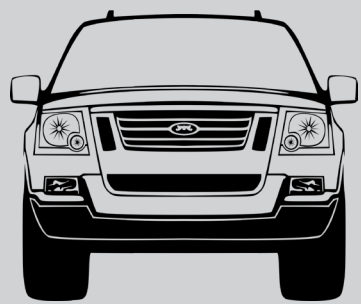
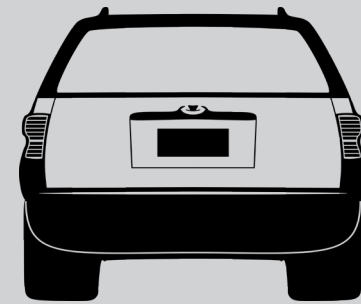
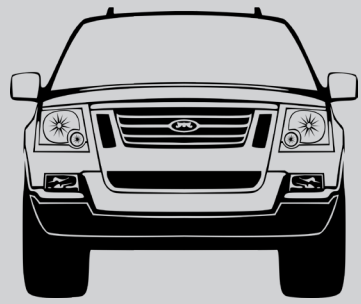
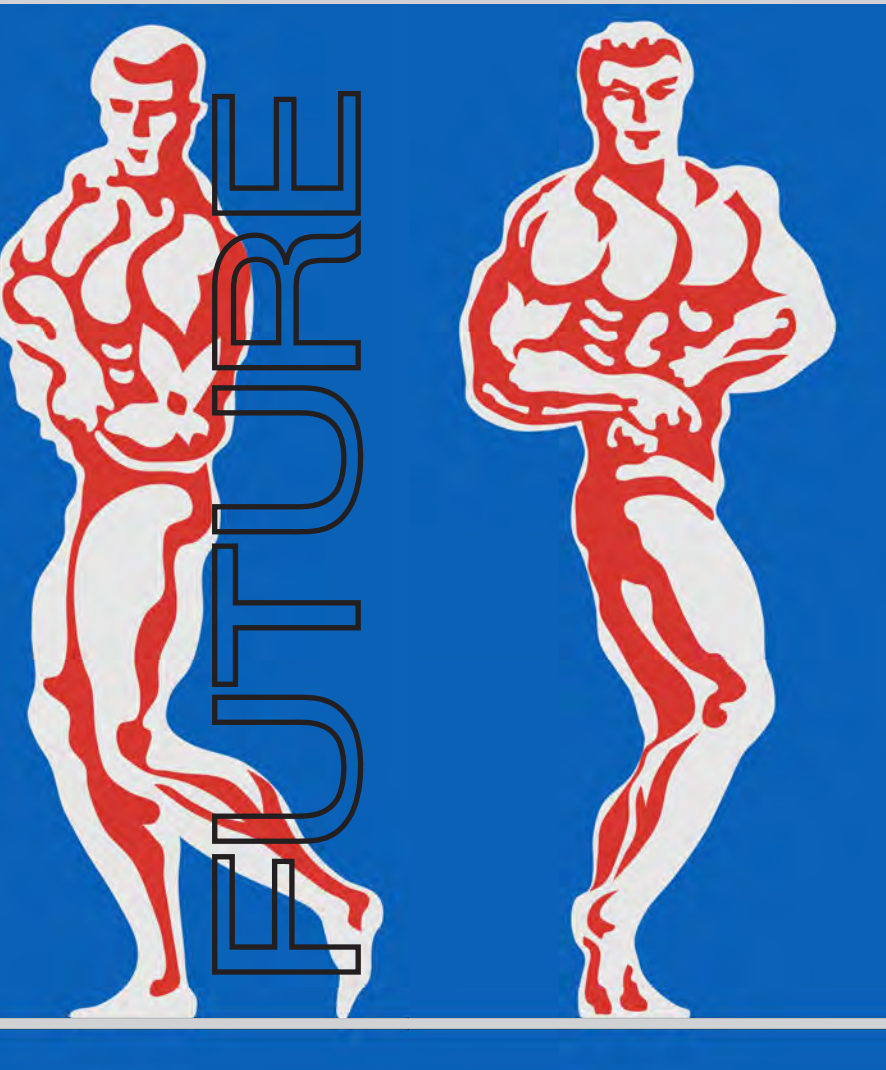
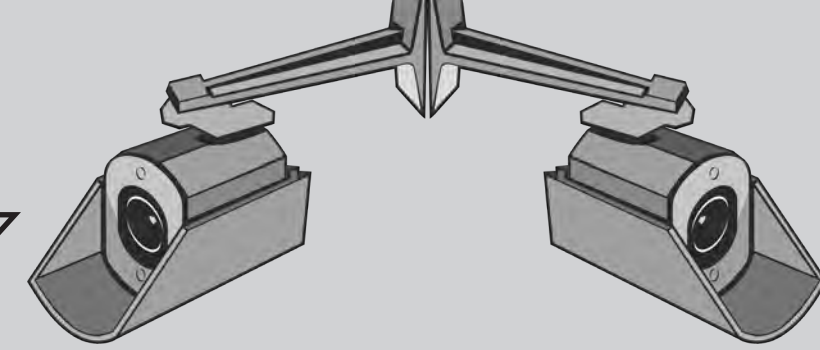

UNION

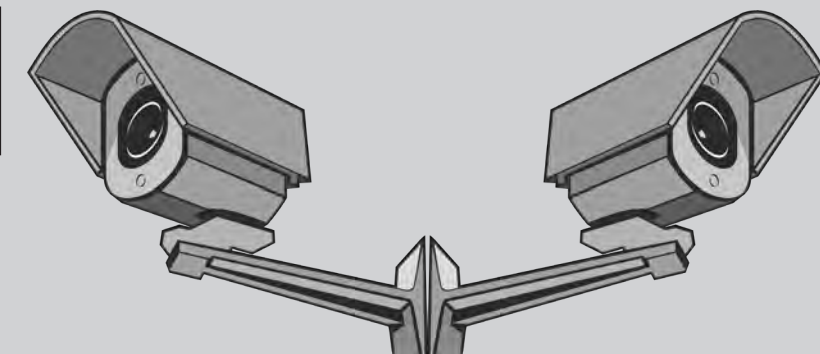

PRUITT

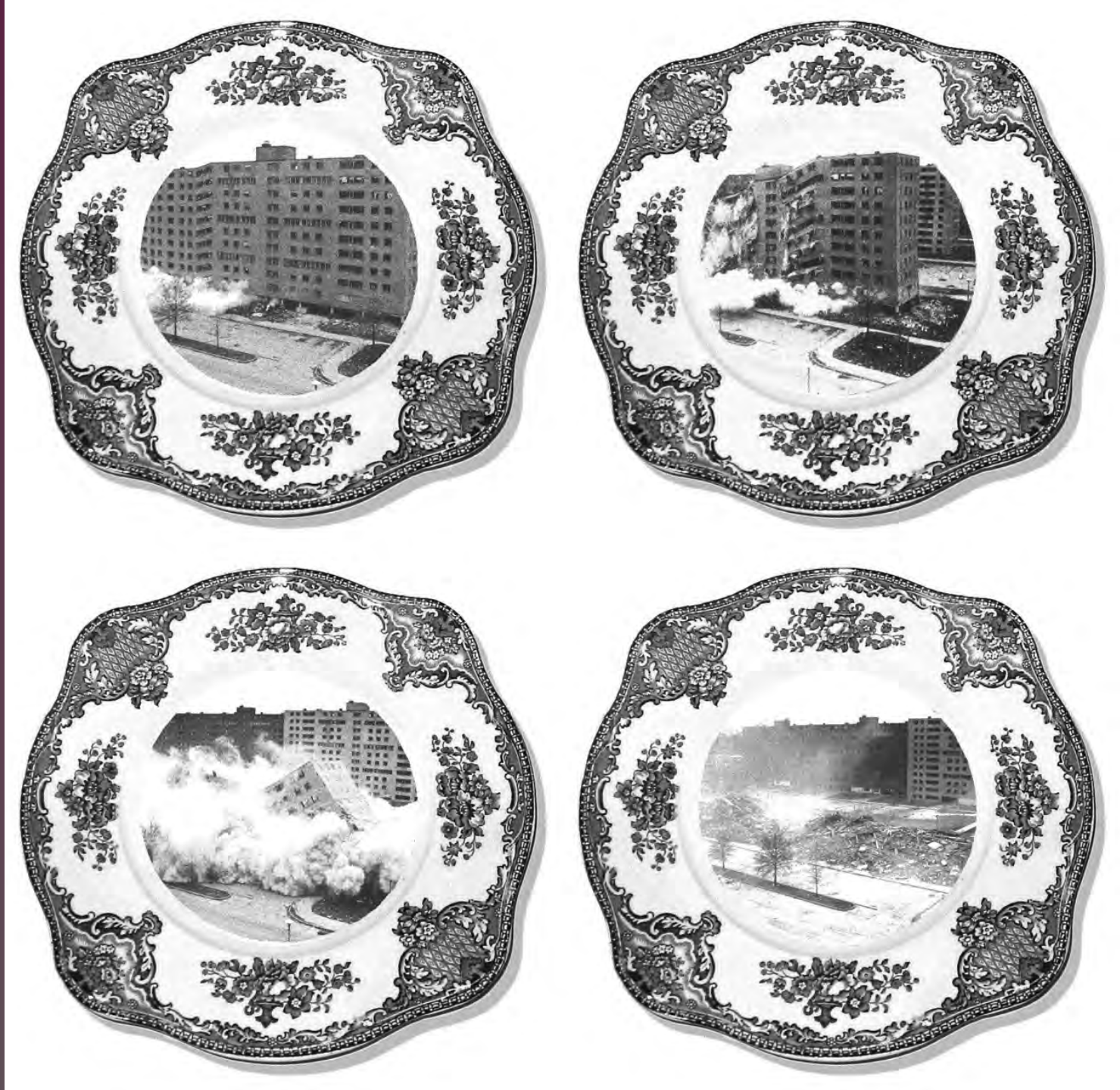

IGOE

URBAN



CHINA

FUTURE

ATLAS

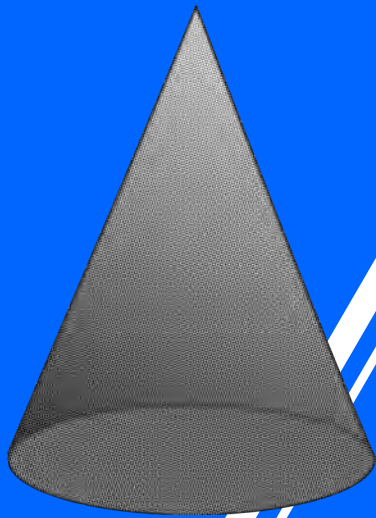
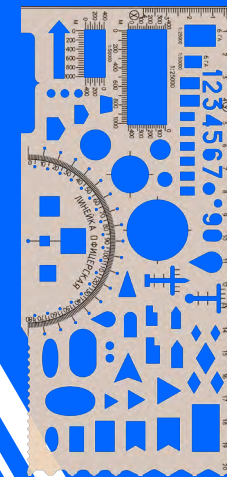
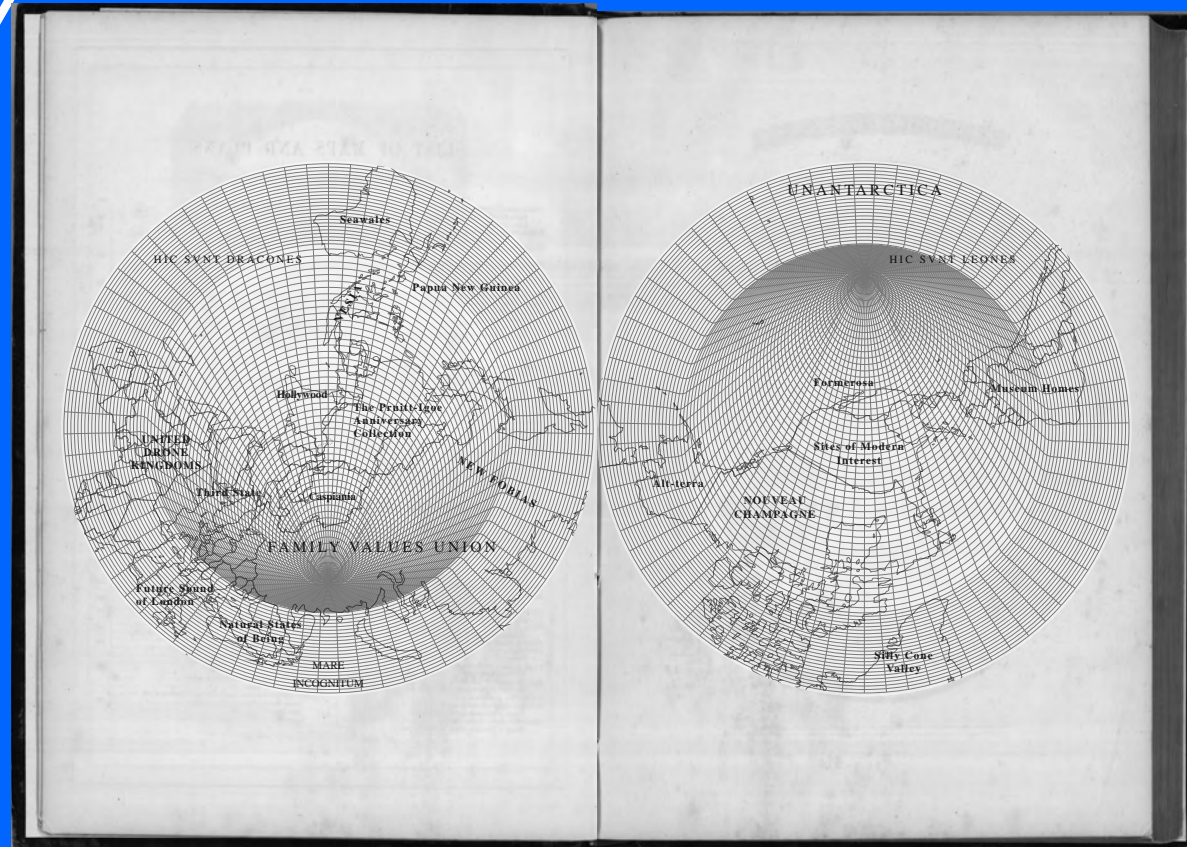
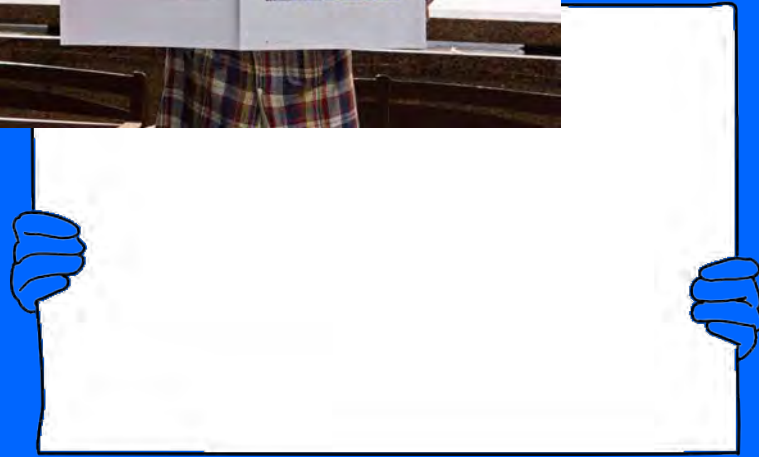

PROXIMA

UTOPIA

THANK YOU

UTOPIA

PROXIMA