

Mary Vayou
BMT Group



Jan Tore
Pedersen
Marlo a.s

FREIGHT

Freight Transport Processes' Standardization
in co-modal transport:

Merging LIM and the e-Freight initiatives

The e-Freight Concept

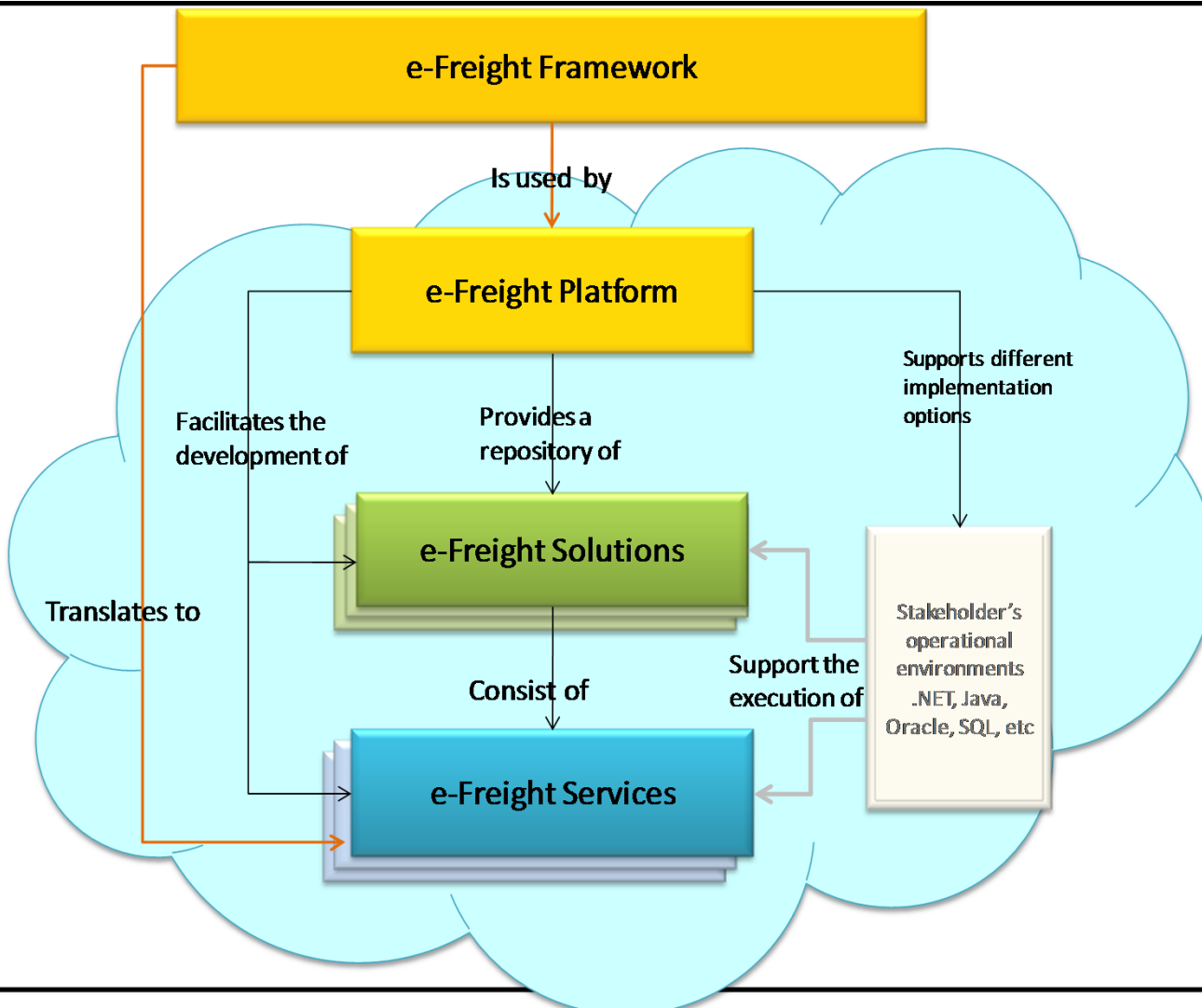

e-Freight receives funding from the EC FP7 Sustainable Surface Transport Programme

The e-Freight Framework



- **A standard framework for freight transport and logistics information exchange covering all transport modes and all stakeholders.**
- **Hang him not, leave him alive – Hang him, not leave him alive**

e-Freight vs the Common Framework



- **Initial definition of the Common Framework:**
 - One *Common Framework* for Information and Communication Systems in Transport and Logistics
- **The e-Freight Framework is a true subset of the Common Framework**

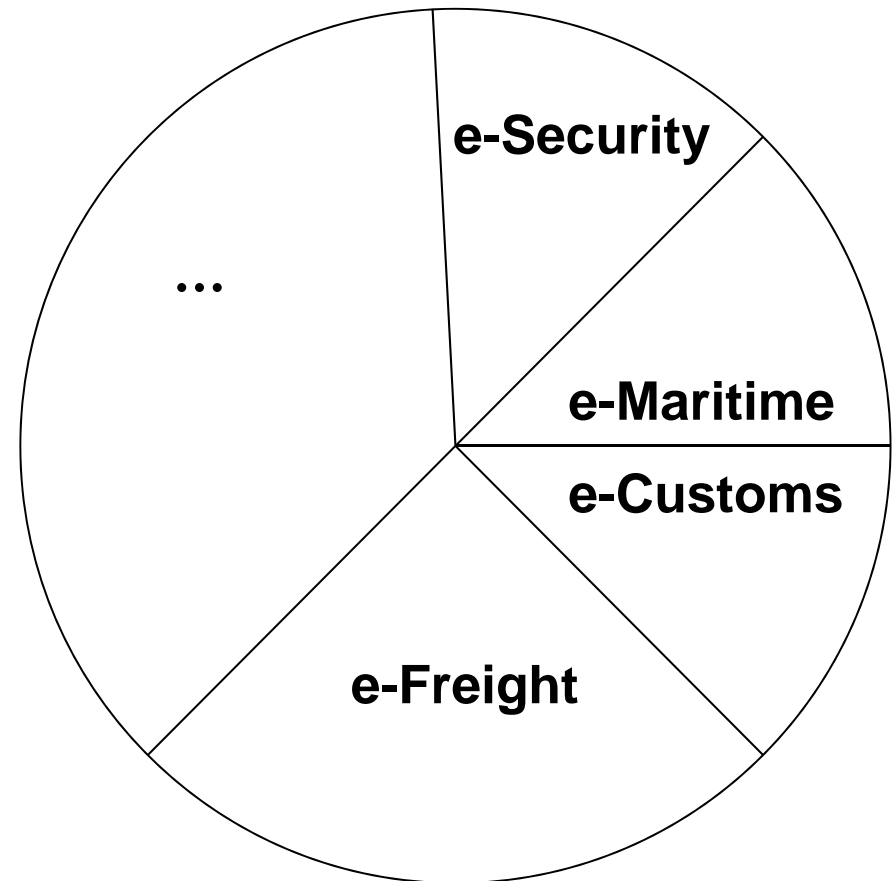

- **Several actors:**

- UN/CEFACT
- OASIS/UBL
- CEN
- **GS1**

- **Tradition:**

- Specifications
- Implementation Guidelines



- **Different interpretations**
- **Limited interoperability**

Backdrop/Ambition

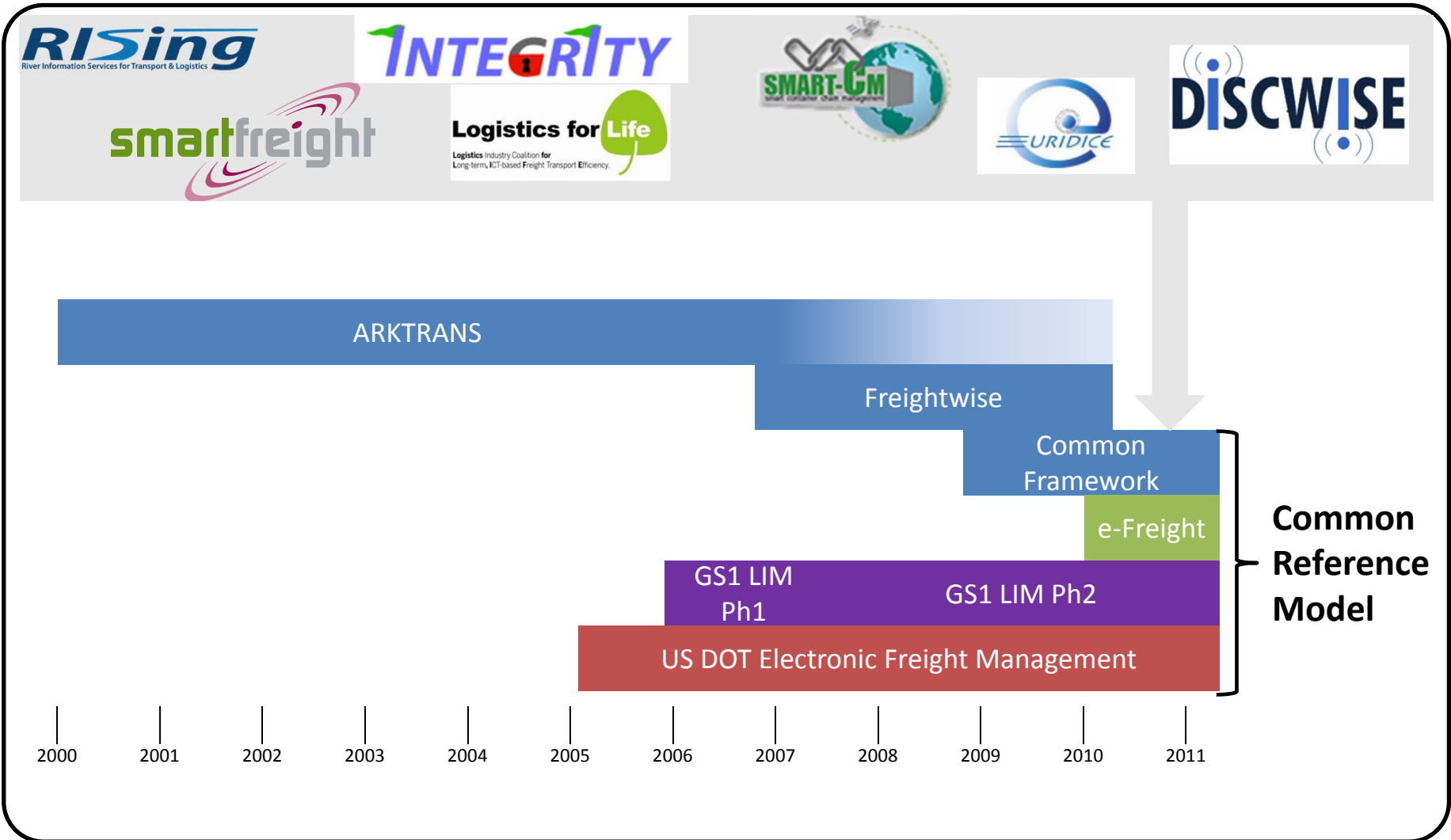

e-Freight receives funding from the EC FP7 Sustainable Surface Transport Programme

First Standardisation Attempt



UBL 2.1

UBL 2.0

EFM

Common
Framework

e-Freight receives funding from the EC FP7 Sustainable Surface Transport Programme

Efficient Cooperation Between Roles



Transport User



**Transportation
Network Manager**



Transport Regulator



Transport Service Provider

Linking Trade and Transport

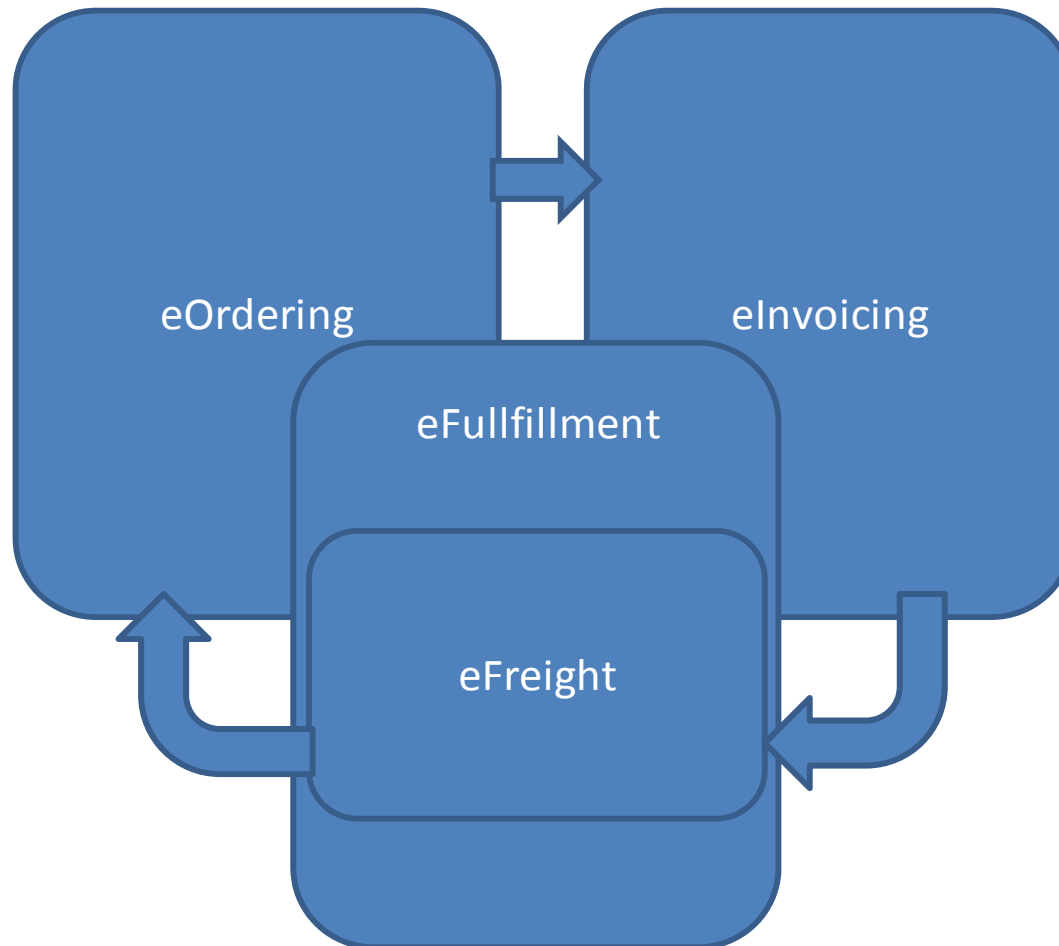

e-Freight receives funding from the EC FP7 Sustainable Surface Transport Programme

Roles



Logistics Services Clients

- Shippers
- Freight Forwarders



Logistics Services Providers

- Terminal Operators
- Transport Operators (train, ship, inland waterways, air)
- Logistics Service Providers



Transportation Infrastructure Managers

- Port authorities
- Rail administrations
- Road administrations



Transport Regulators

- Customs
- Safety Agencies
- Security Agencies

Consignee

Consignor

Hierarchical Load Units

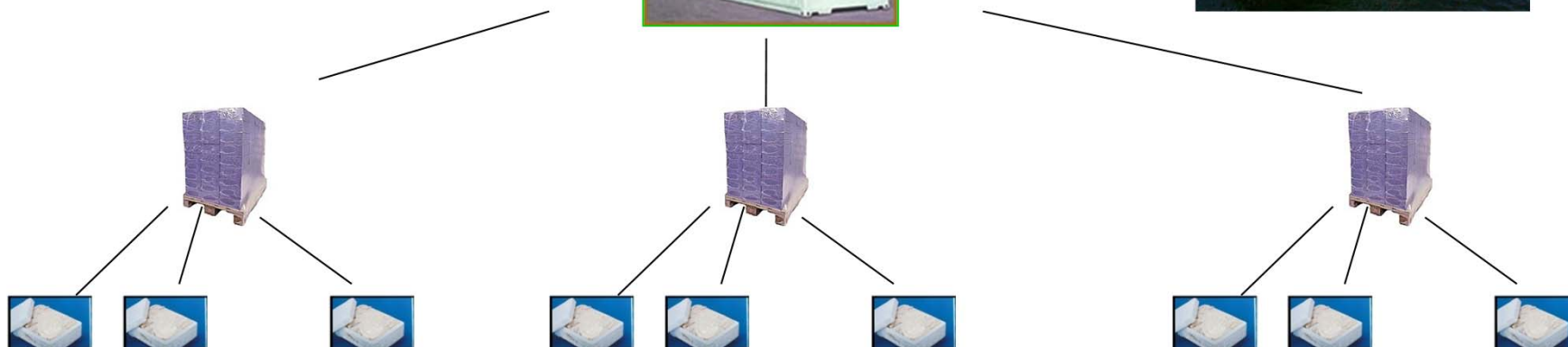

e-Freight receives funding from the EC FP7 Sustainable Surface Transport Programme

LIM Scope

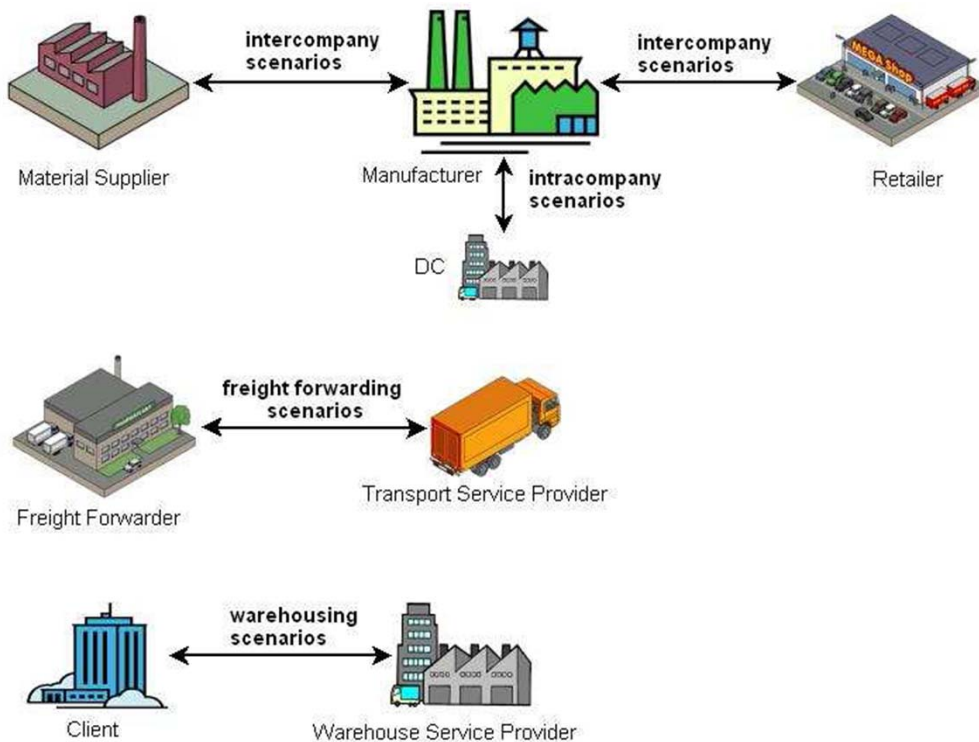

- **Essentially focused on road transport**

e-Freight Scope

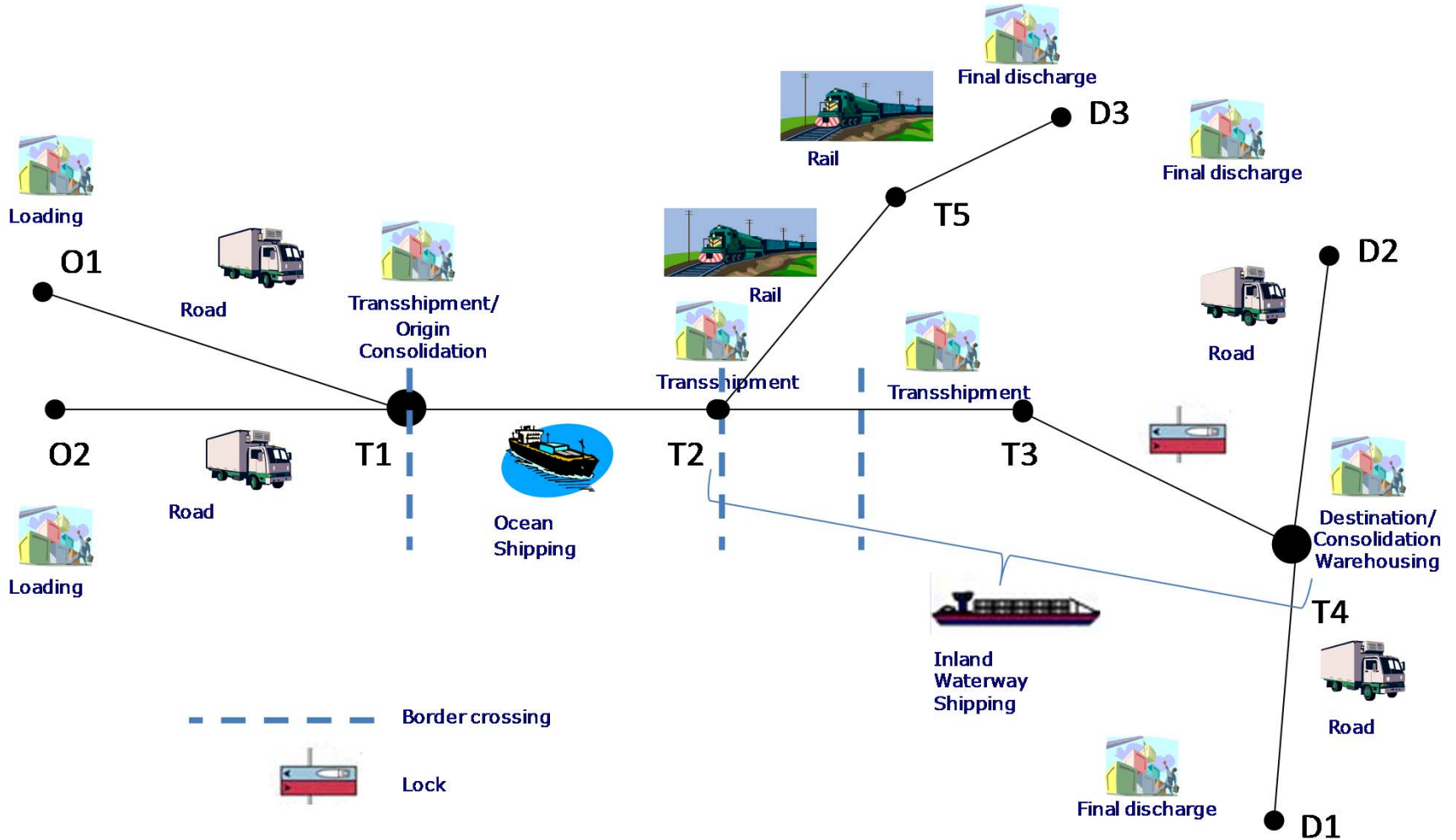

e-Freight receives funding from the EC FP7 Sustainable Surface Transport Programme

Freightwise Processes



FREIGHT

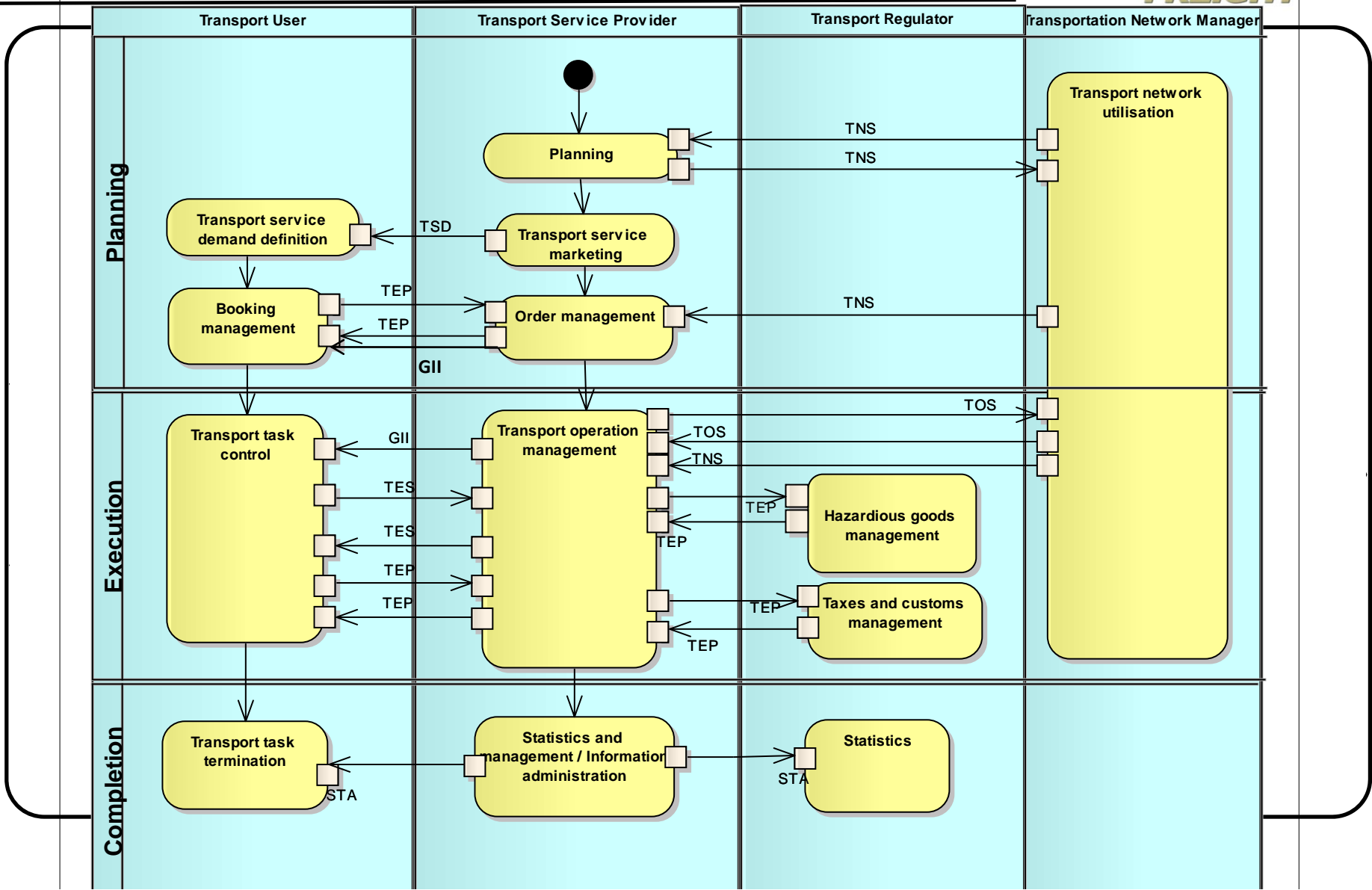

GS1 LIM Processes



Interoperation Agreement	Master Data Alignment	Logistics Service Conditions	Planning	Warehousing	Transport	Financial Settlement
--------------------------	-----------------------	------------------------------	----------	-------------	-----------	----------------------

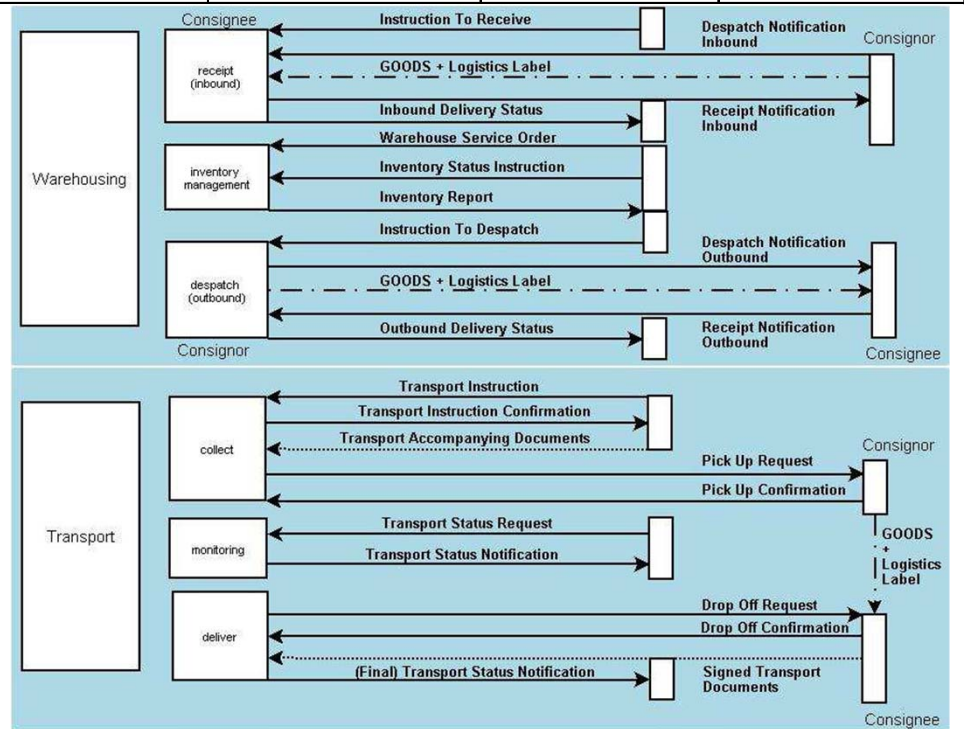
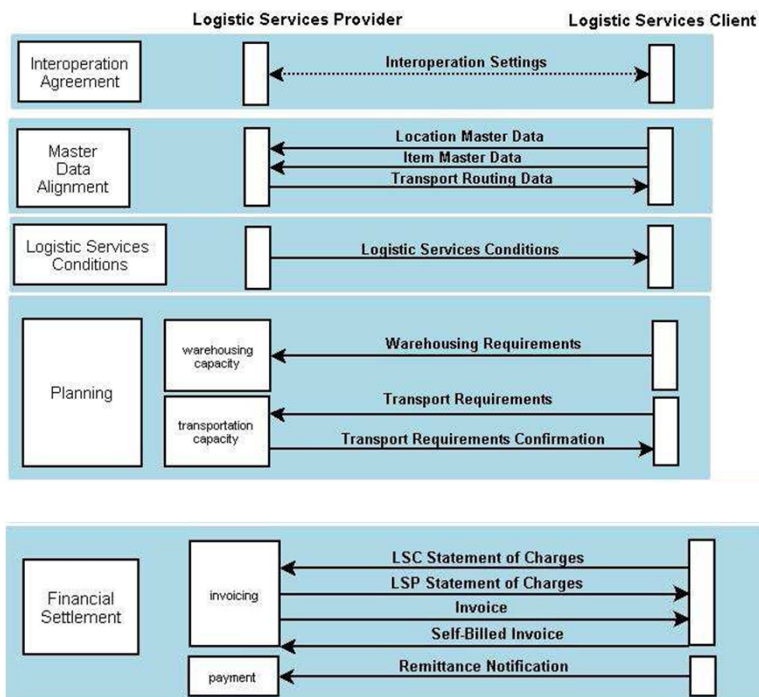

Consolidated Business Processes



Interoperation Agreement	Master Data Alignment	Logistics Service Conditions	Planning	Warehousing	Transport	Financial Settlement
---------------------------------	------------------------------	-------------------------------------	-----------------	--------------------	------------------	-----------------------------

+

Planning	Execution	Completion
-----------------	------------------	-------------------

=

Interoperation Agreement	Master Data Alignment	Logistics Service Conditions	Planning	Scheduling	Execution	Completion
---------------------------------	------------------------------	-------------------------------------	-----------------	-------------------	------------------	-------------------

Consolidated Business Processes



analysis Business Process Model

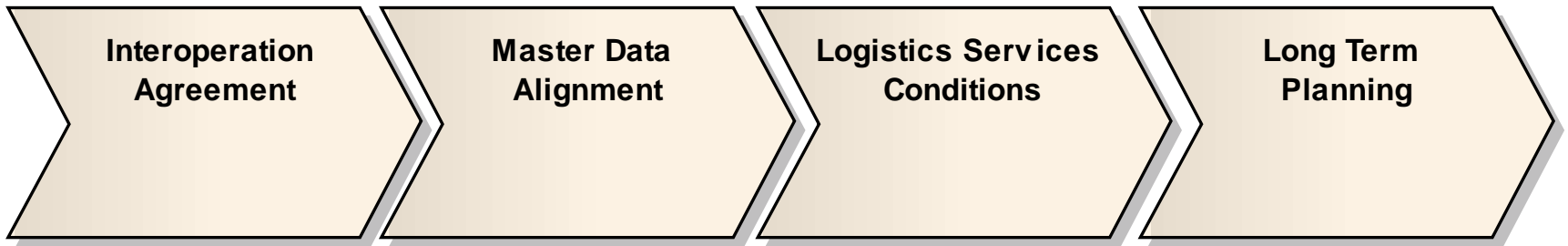

analysis Business Process Model

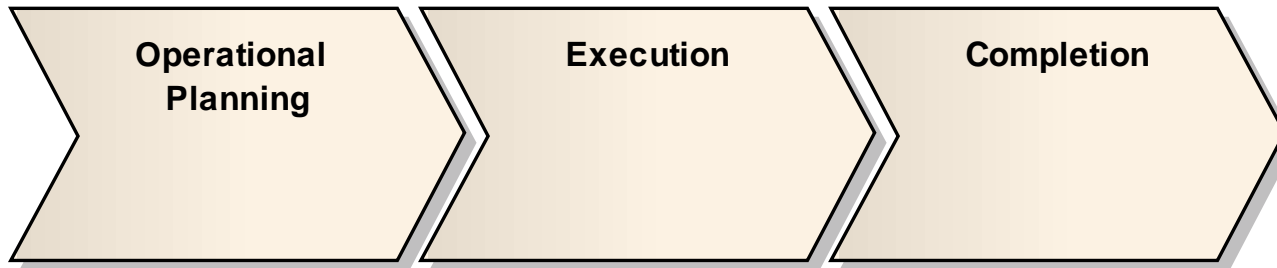

Scope



- **Co-modality (all modes and combination of modes)**
- **Warehousing**

Top Level Diagram

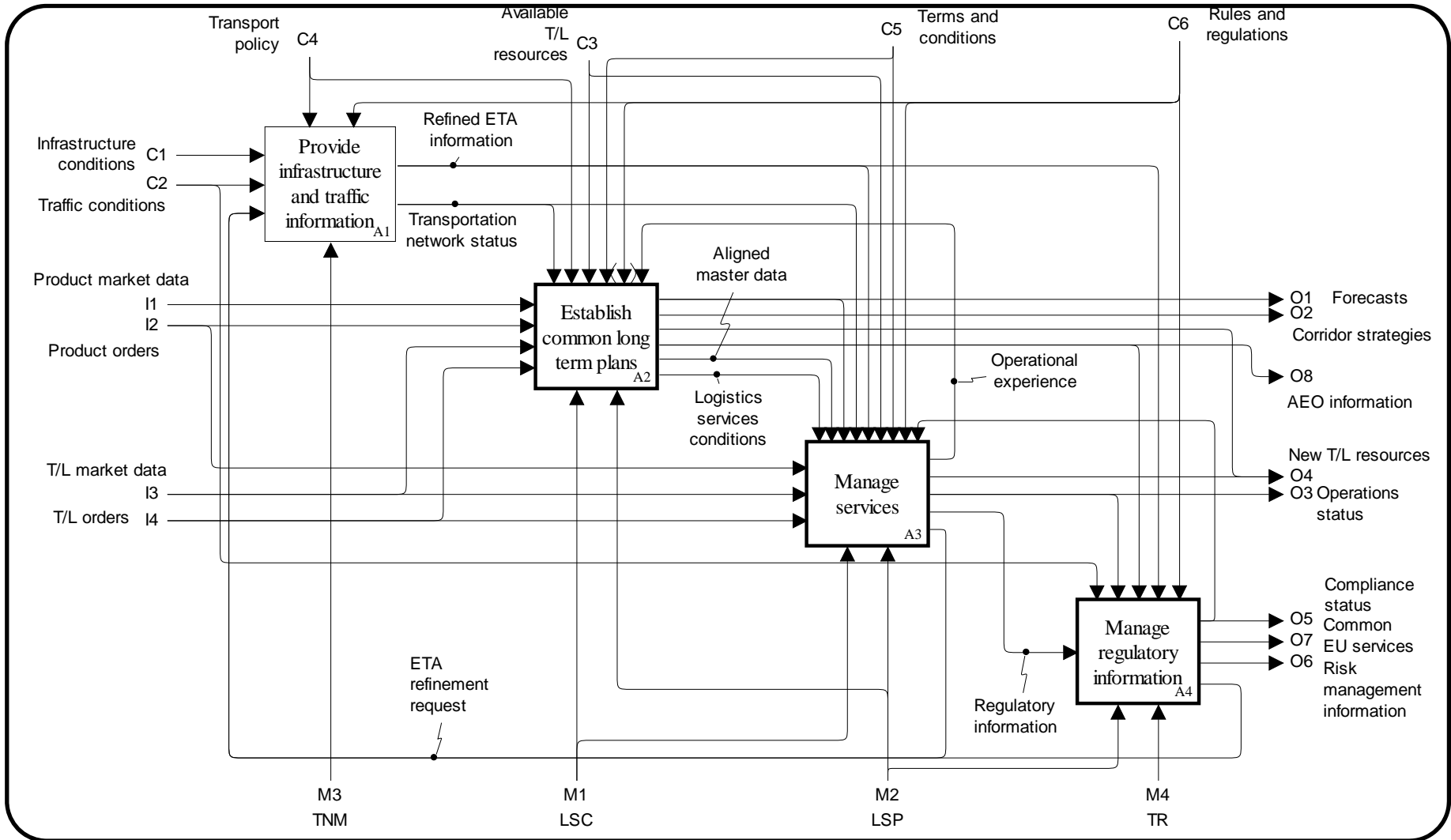

e-Freight receives funding from the EC FP7 Sustainable Surface Transport Programme

Context

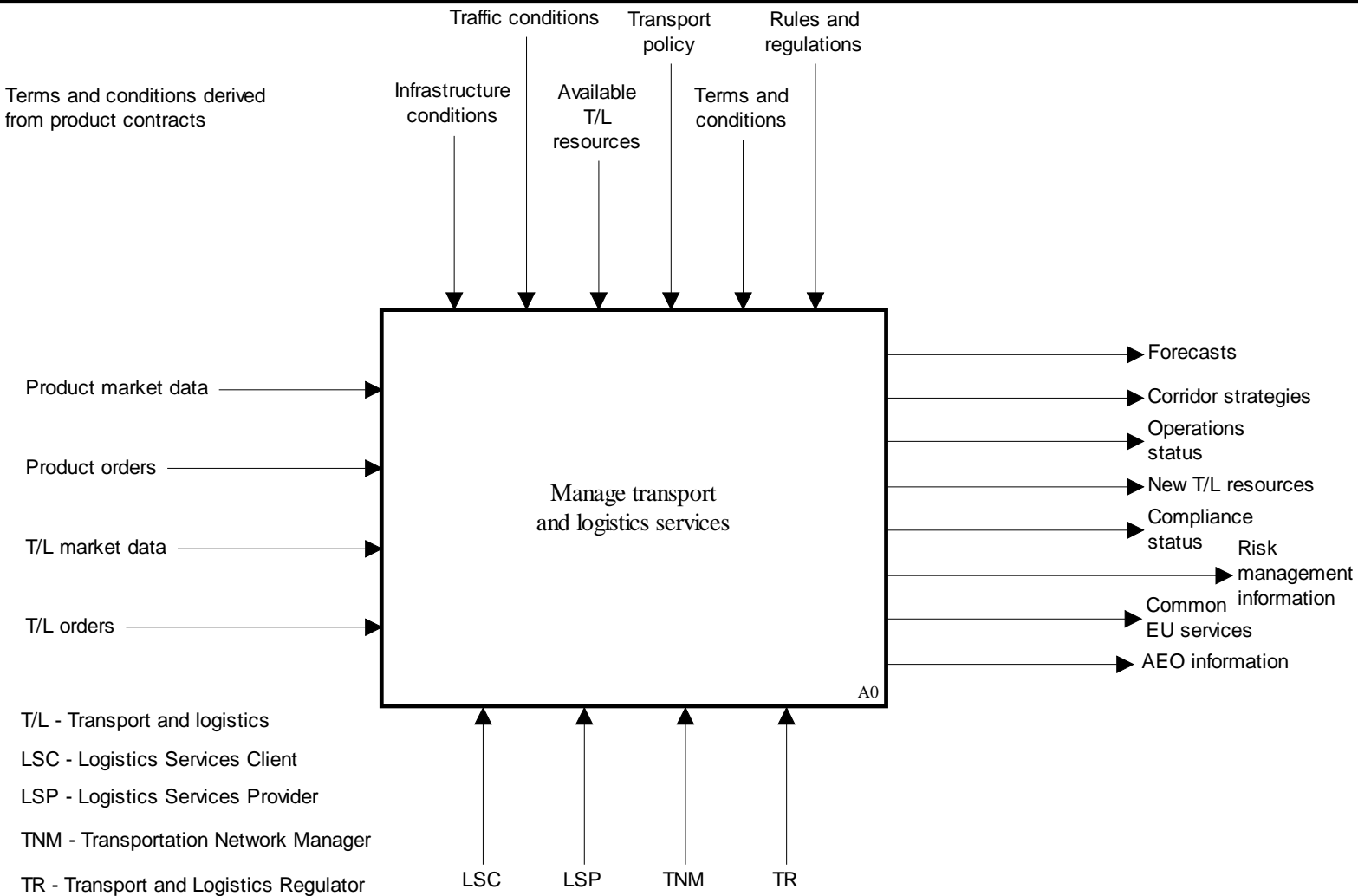

e-Freight receives funding from the EC FP7 Sustainable Surface Transport Programme

Establish Long Term Plans

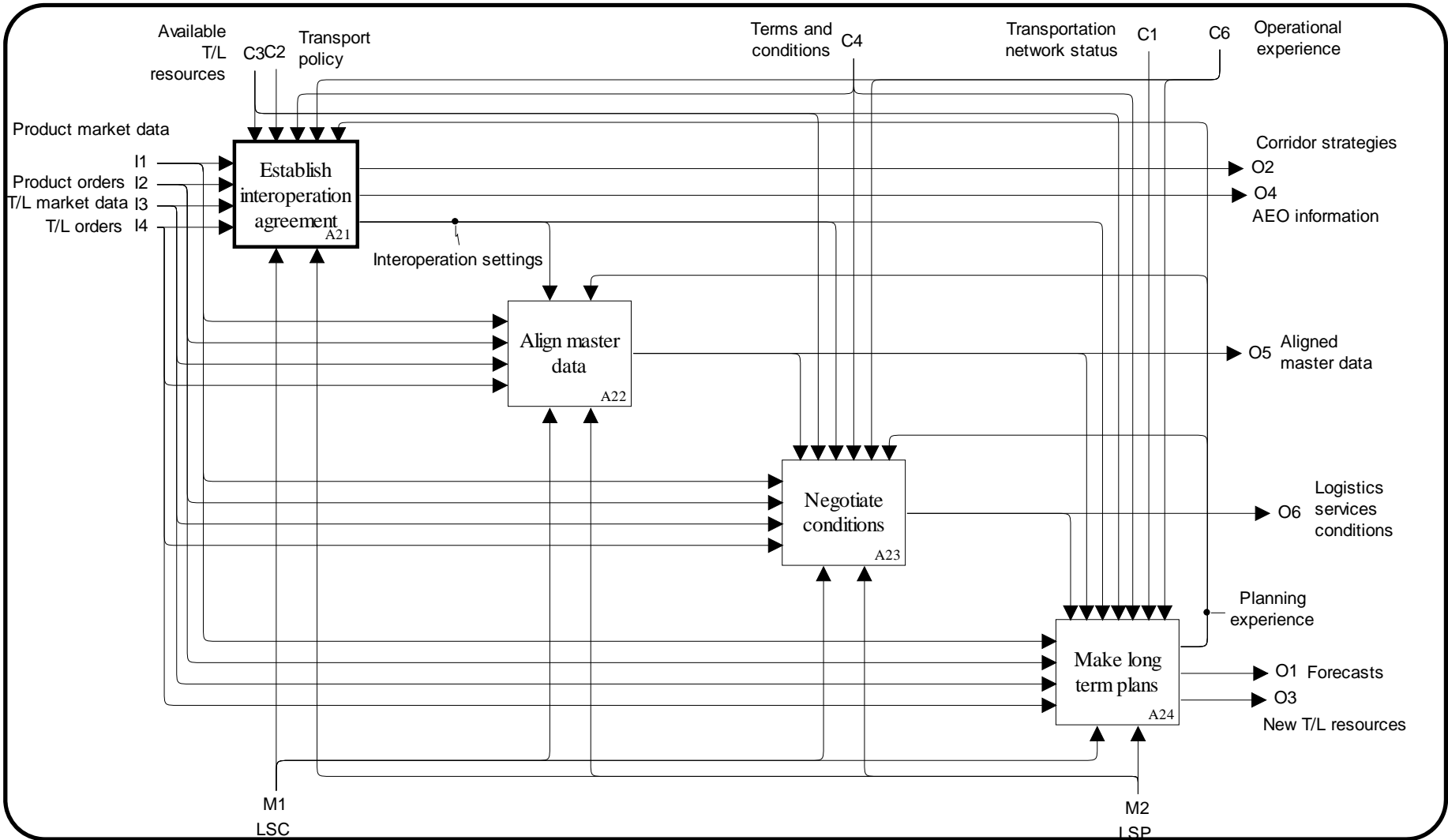

e-Freight receives funding from the EC FP7 Sustainable Surface Transport Programme

Establish Interoperation Agreement

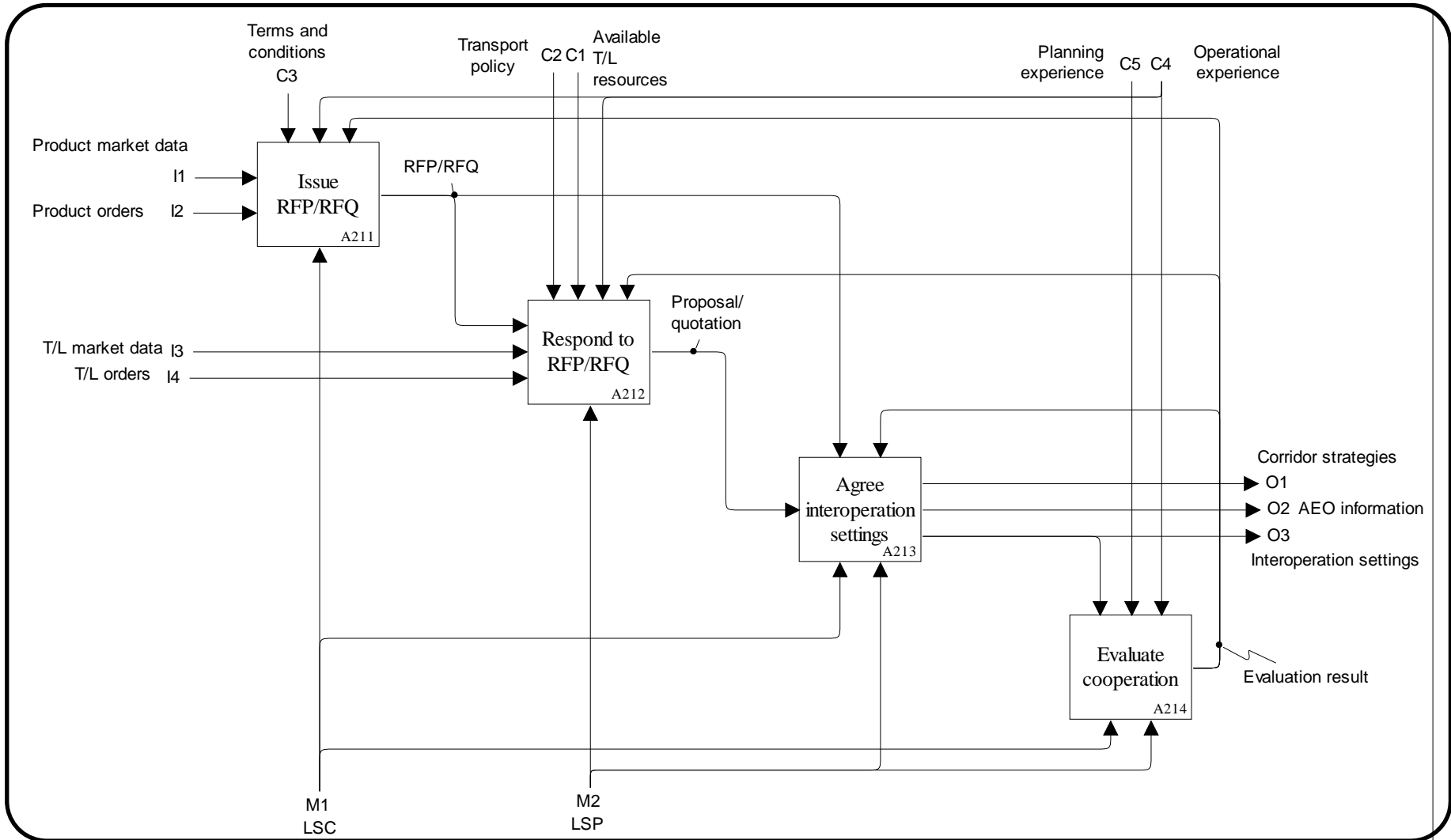

e-Freight receives funding from the EC FP7 Sustainable Surface Transport Programme

Manage Services

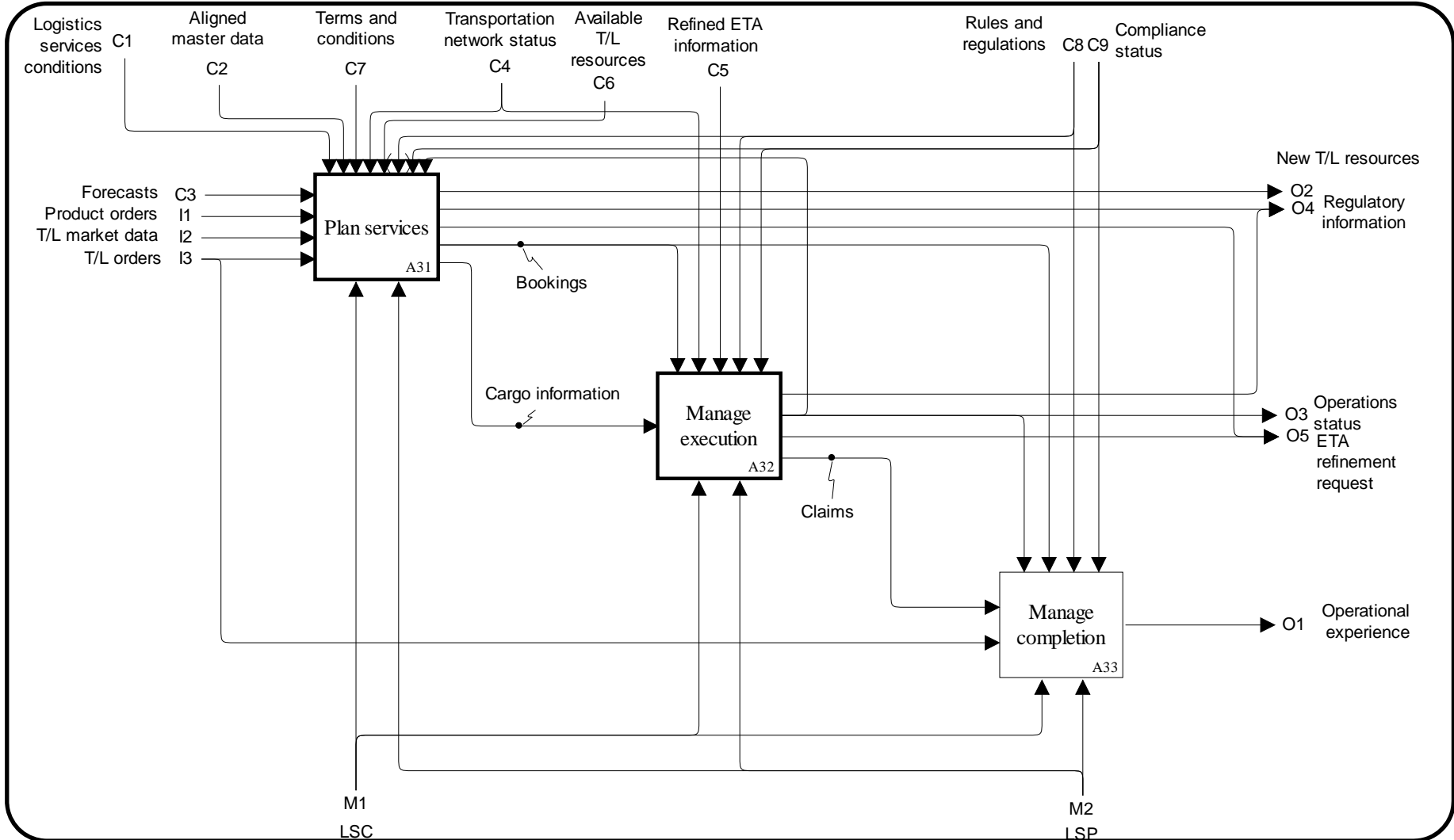

e-Freight receives funding from the EC FP7 Sustainable Surface Transport Programme

Plan Services

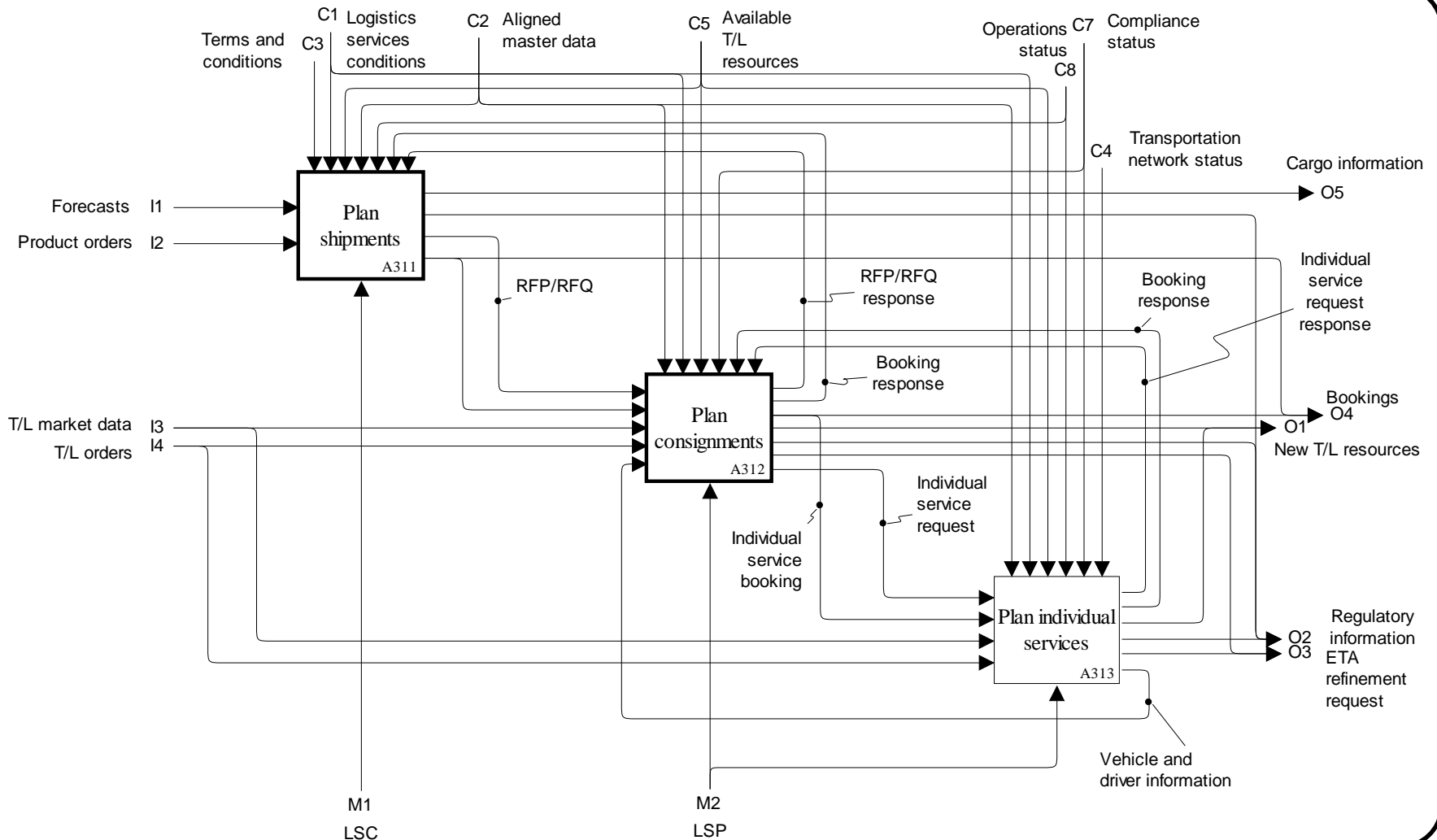

Plan Shipments

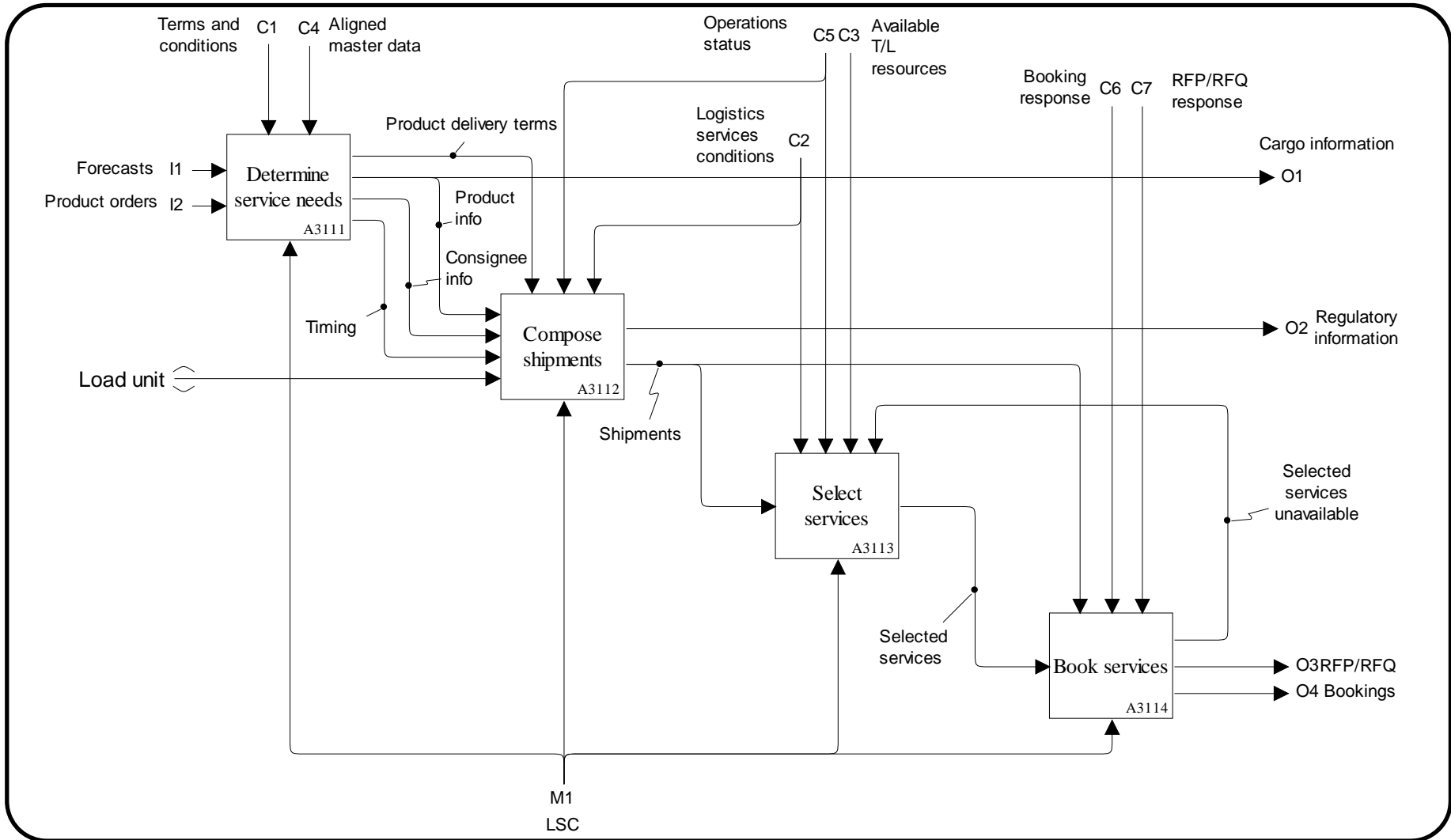

e-Freight receives funding from the EC FP7 Sustainable Surface Transport Programme

Plan Consignments

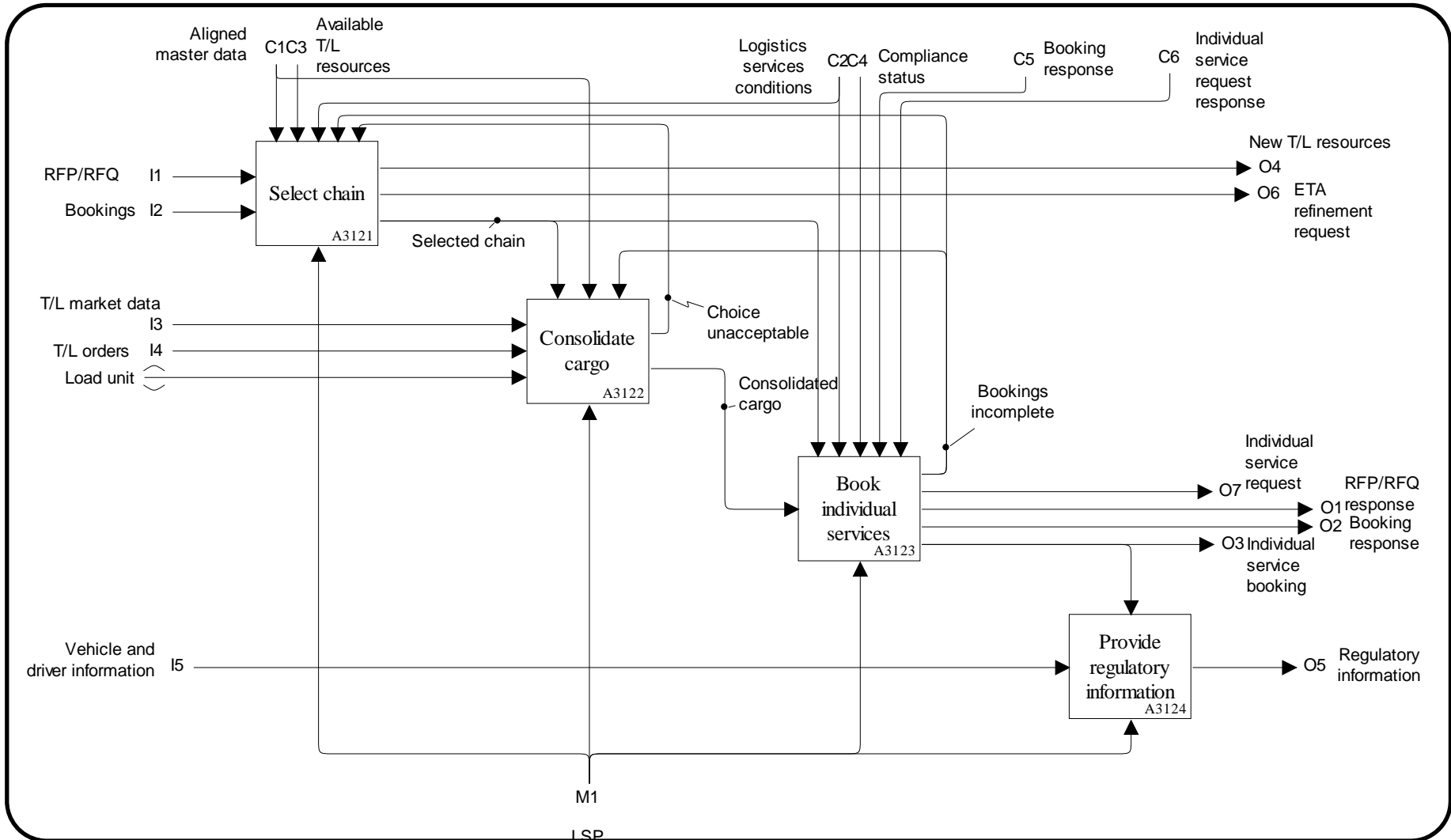

Manage Execution

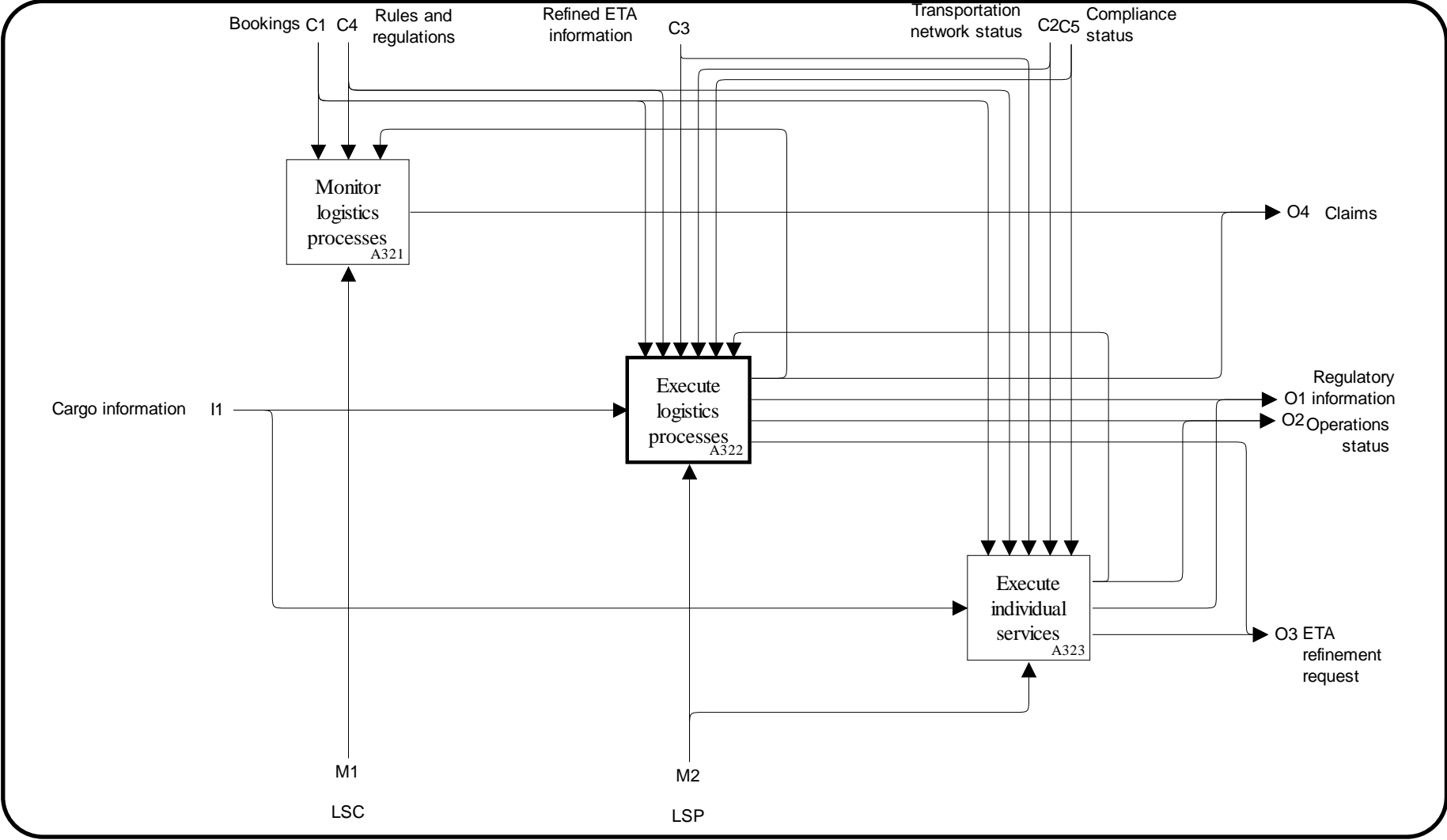

e-Freight receives funding from the EC FP7 Sustainable Surface Transport Programme

Execute Logistics Processes

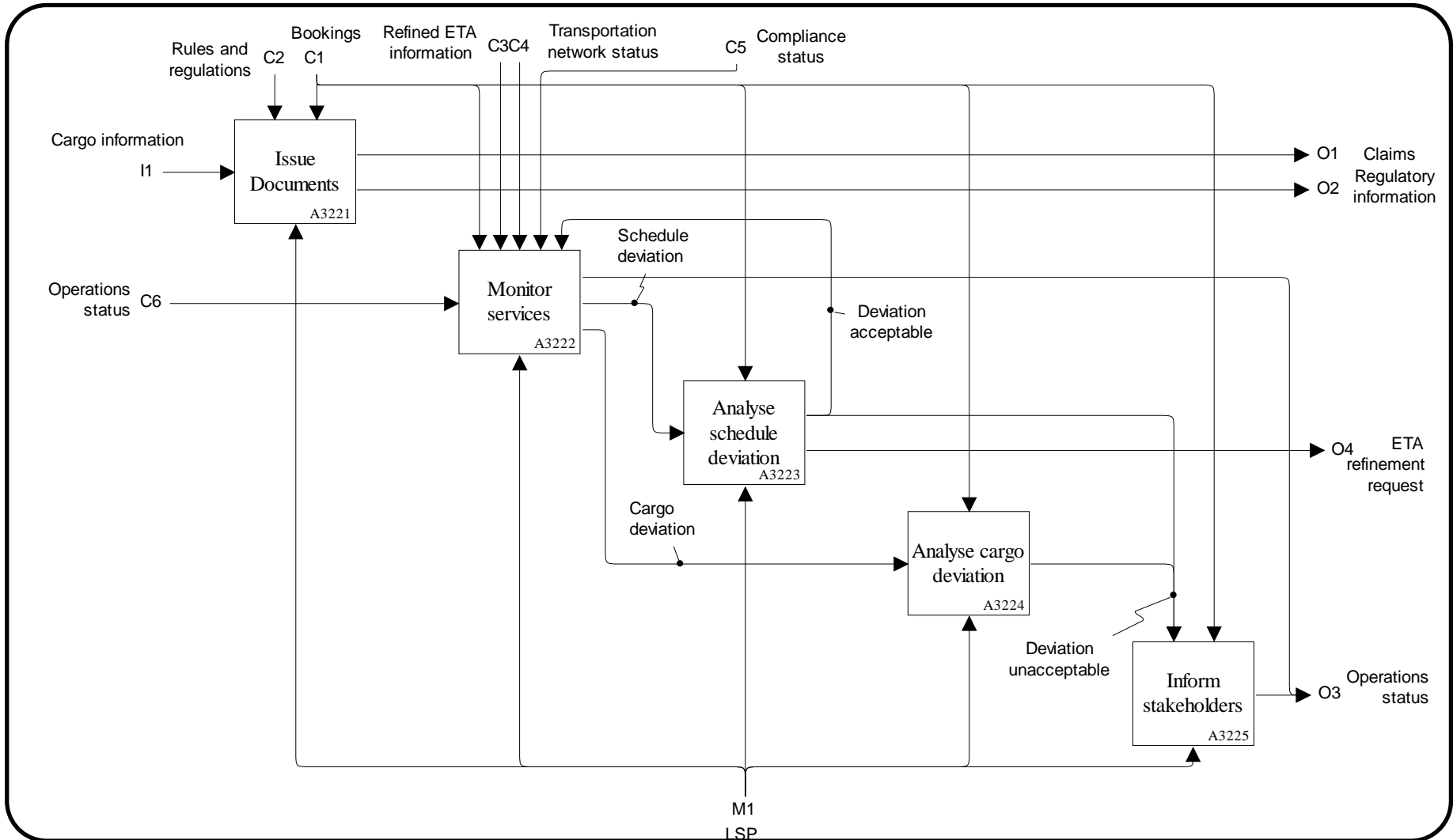

e-Freight receives funding from the EC FP7 Sustainable Surface Transport Programme

Manage Regulatory Information

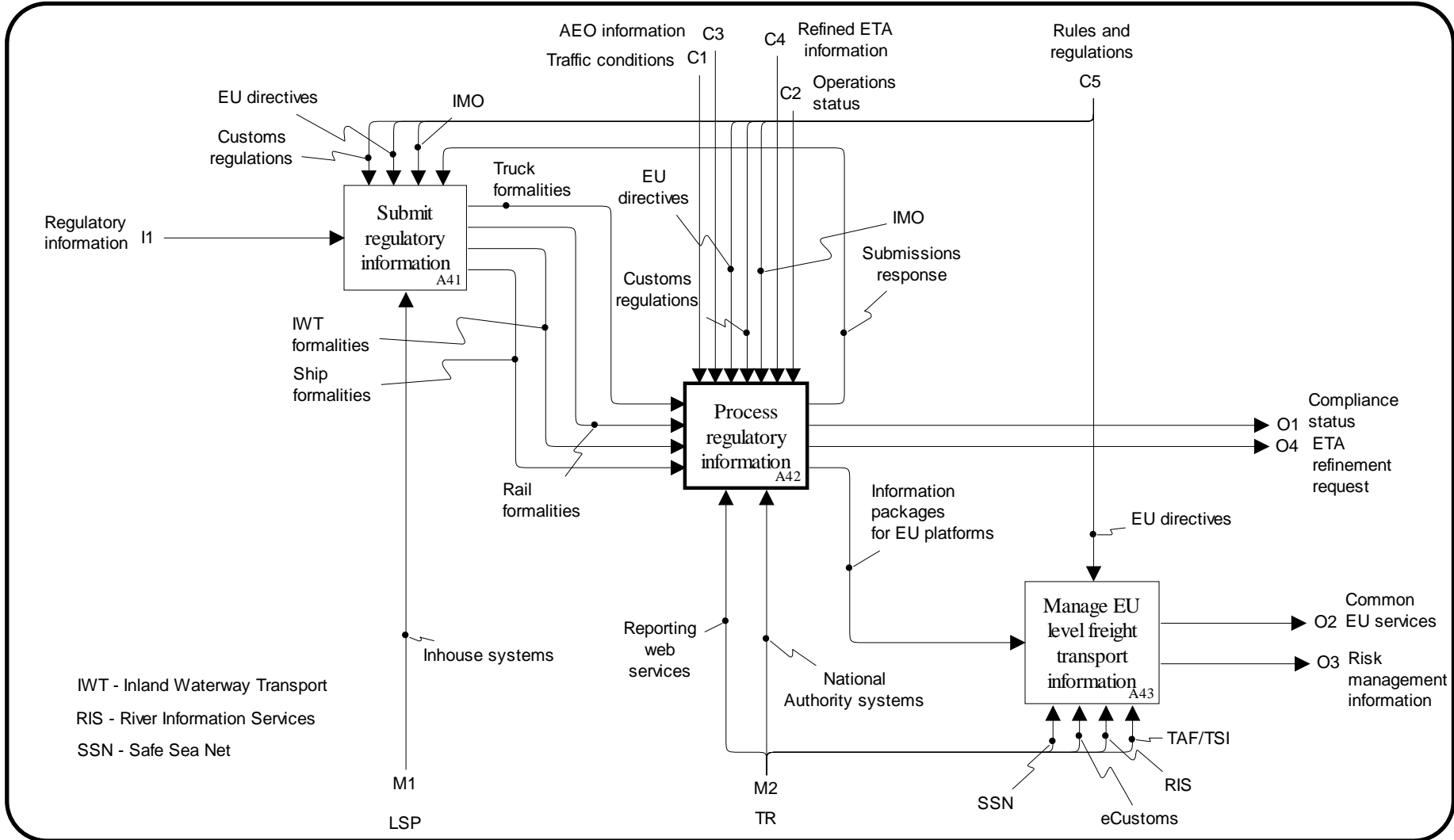

e-Freight receives funding from the EC FP7 Sustainable Surface Transport Programme

Process Regulatory Information

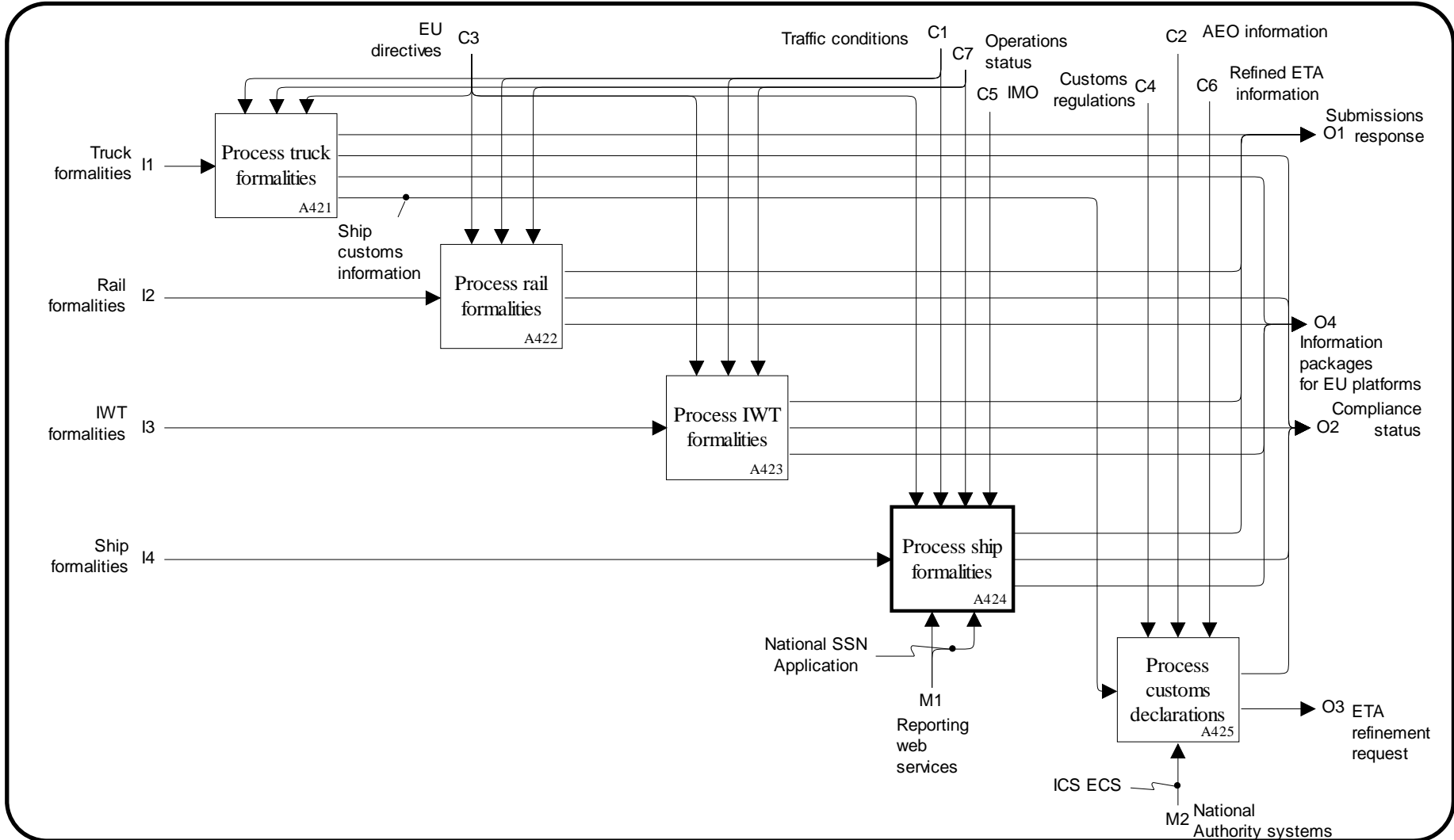

e-Freight receives funding from the EC FP7 Sustainable Surface Transport Programme

Lessons Learned



- **Despite very different origins and approaches, e-Freight (Common Framework development) and the GS1 LIM initiative have more things in common than differences**
- **The Business Processes are completely harmonised.**
- **Message alignment is ongoing, but requires more calendar time**



FREIGHT

Thank You!