

# RAZVOJ IN PRIHODNOST NANOFOTONSKIH INTEGRIRANIH VEZIJ

Benjamin Lipovšek, Franc Smole, Marko Topič

Univerza v Ljubljani

Fakulteta za elektrotehniko

Tržaška cesta 25, SI-1000 Ljubljana



# Laboratorij za Fotovoltaiško in Optoelektroniko

Univerza v Ljubljani  
Fakulteta *za Elektrotehniko*

Tržaška cesta 25  
1000 Ljubljana



## Vodja

prof. dr. Marko Topič

## Raziskovalci

prof. dr. Franc Smole  
izr. prof. dr. Janez Krč  
doc. dr. Marko Jankovec  
dr. Kristijan Brecl  
dr. Urša Opara Krašovec  
dr. Boštjan Glažar  
dr. Andrej Čampa  
dr. Marko Berginc  
dr. Mateja Hočevnar  
dr. Benjamin Lipovšek

## Mladi raziskovalci

Matevž Bokalič  
Marija Drev  
Miha Filipič  
Blaž Kirn  
Gašper Matič  
Martin Sever  
Tjaša Vidmar

## Tehnična sodelavca

Jože Stepan  
Marijan Žurga

# Telekomunikacije

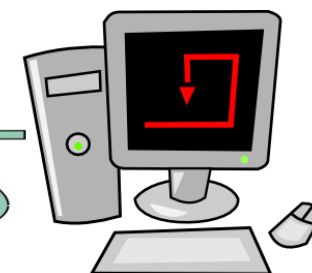
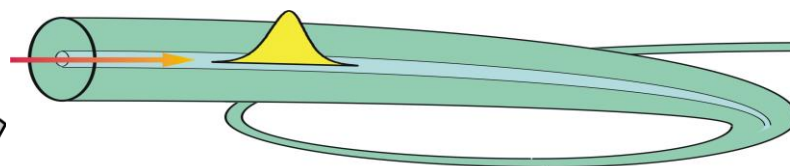

# Optične telekomunikacije

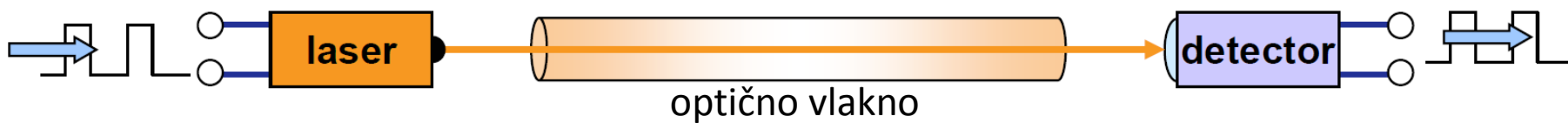

# Optične telekomunikacije

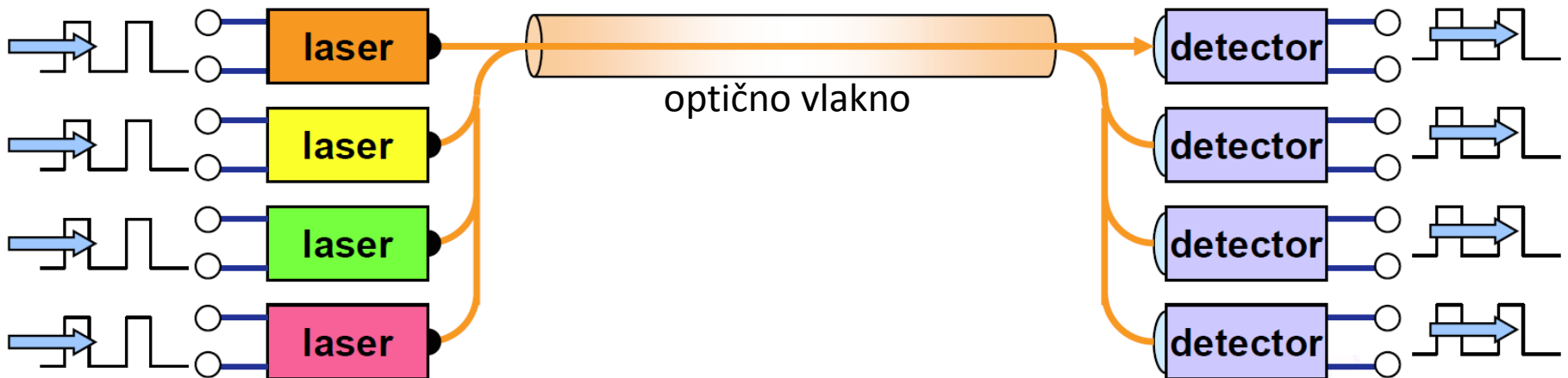

vir: IMEC

# Optične telekomunikacije

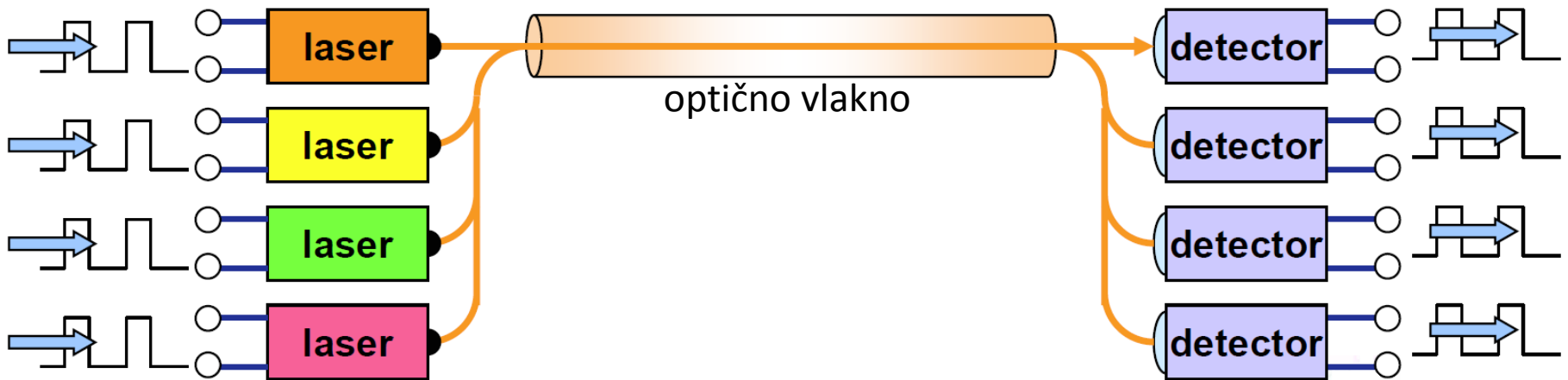

vir: IMEC

- › Integracija na nivoju čipa?
- › Optična komunikacija med mikroprocesorji?
- › Optična komunikacija med mikroprocesorjem in polnilnikom?

# Fotonska integrirana vezja (IBM, 2012)

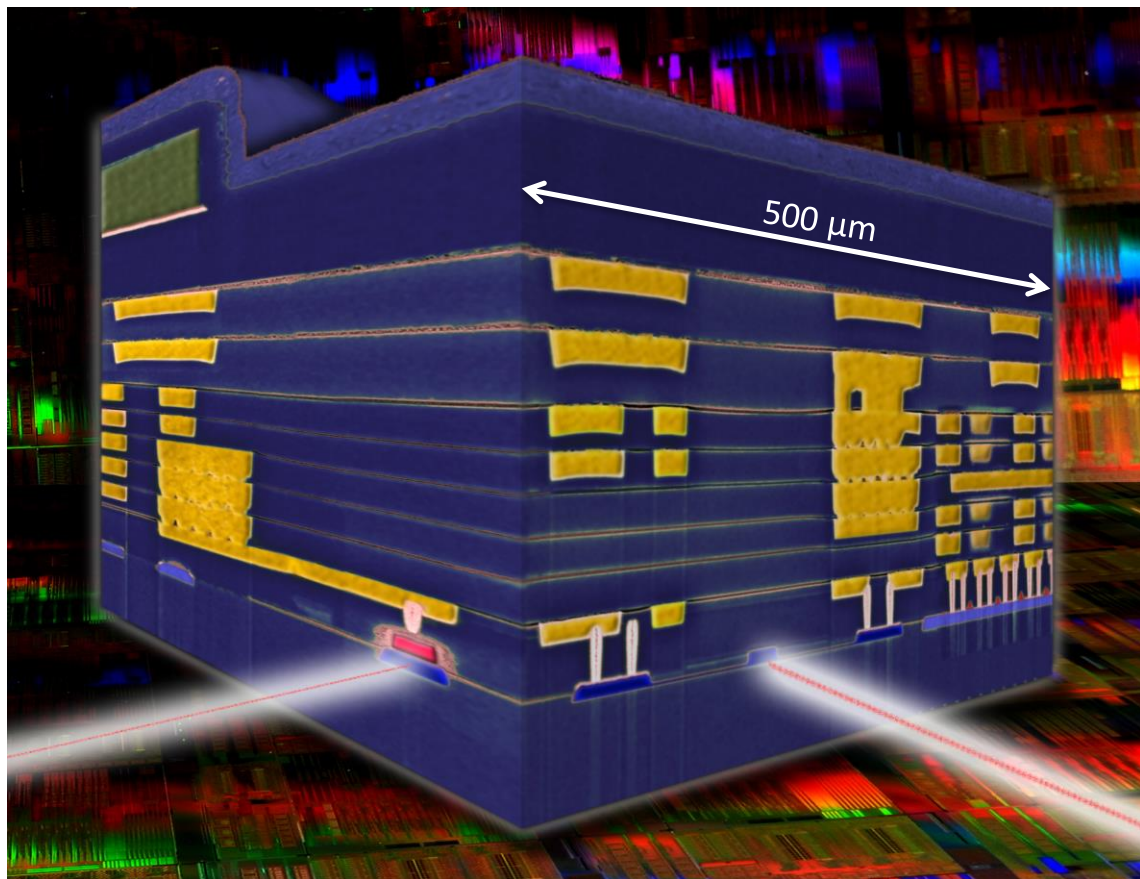

vir: IBM

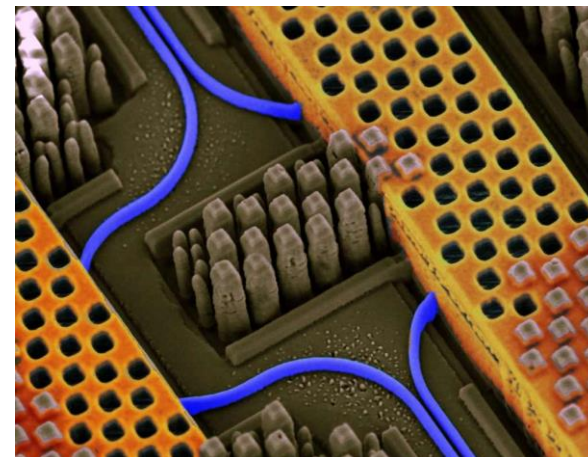

- › 90 nm CMOS tehnologija
- › Integracija elektronskih in fotonskih elementov
- › Hitrost 25 Gb/s na kanal
- › Nizka cena!

# Fotonska integrirana vezja

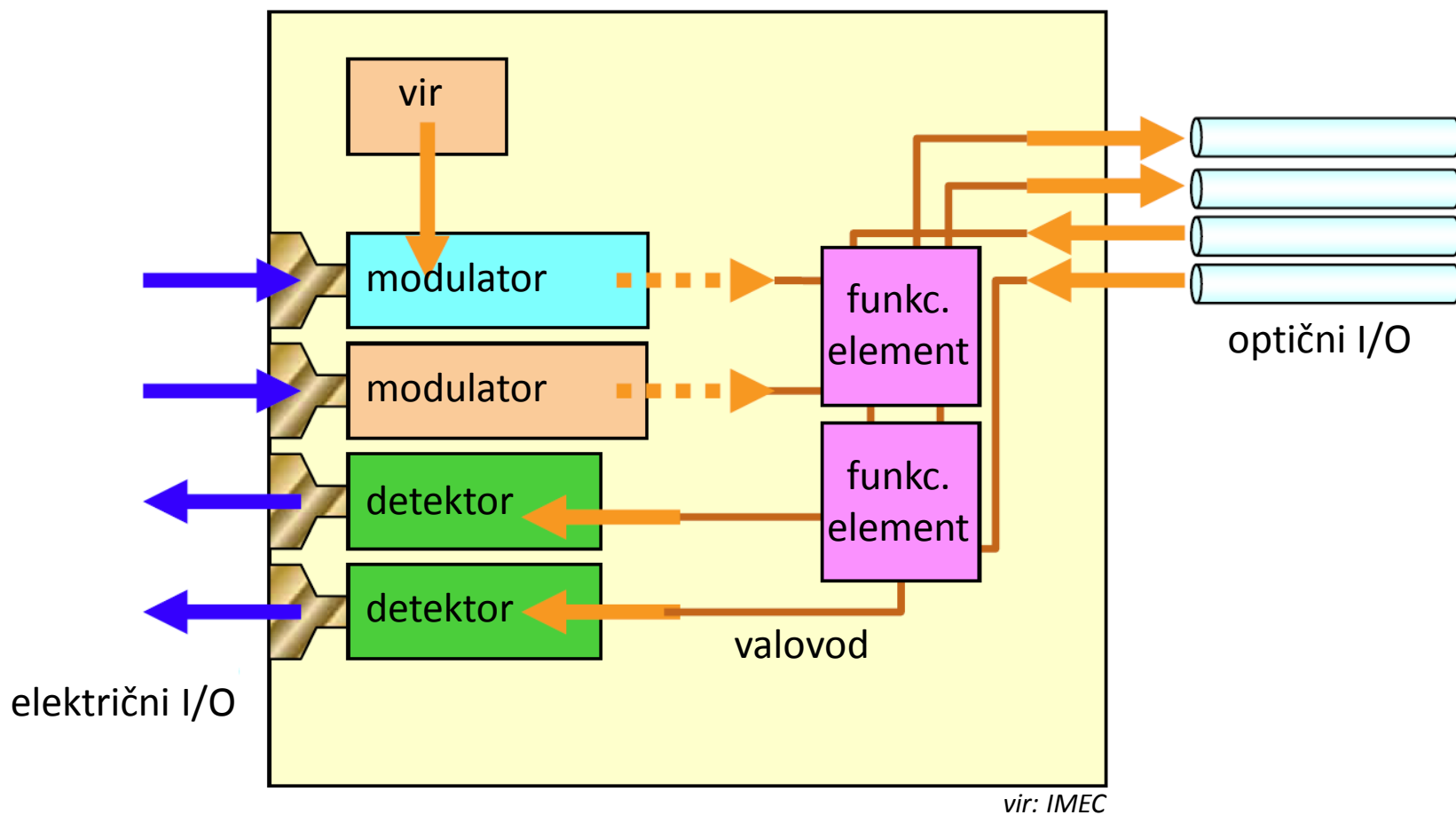



# Fotonska integrirana vezja

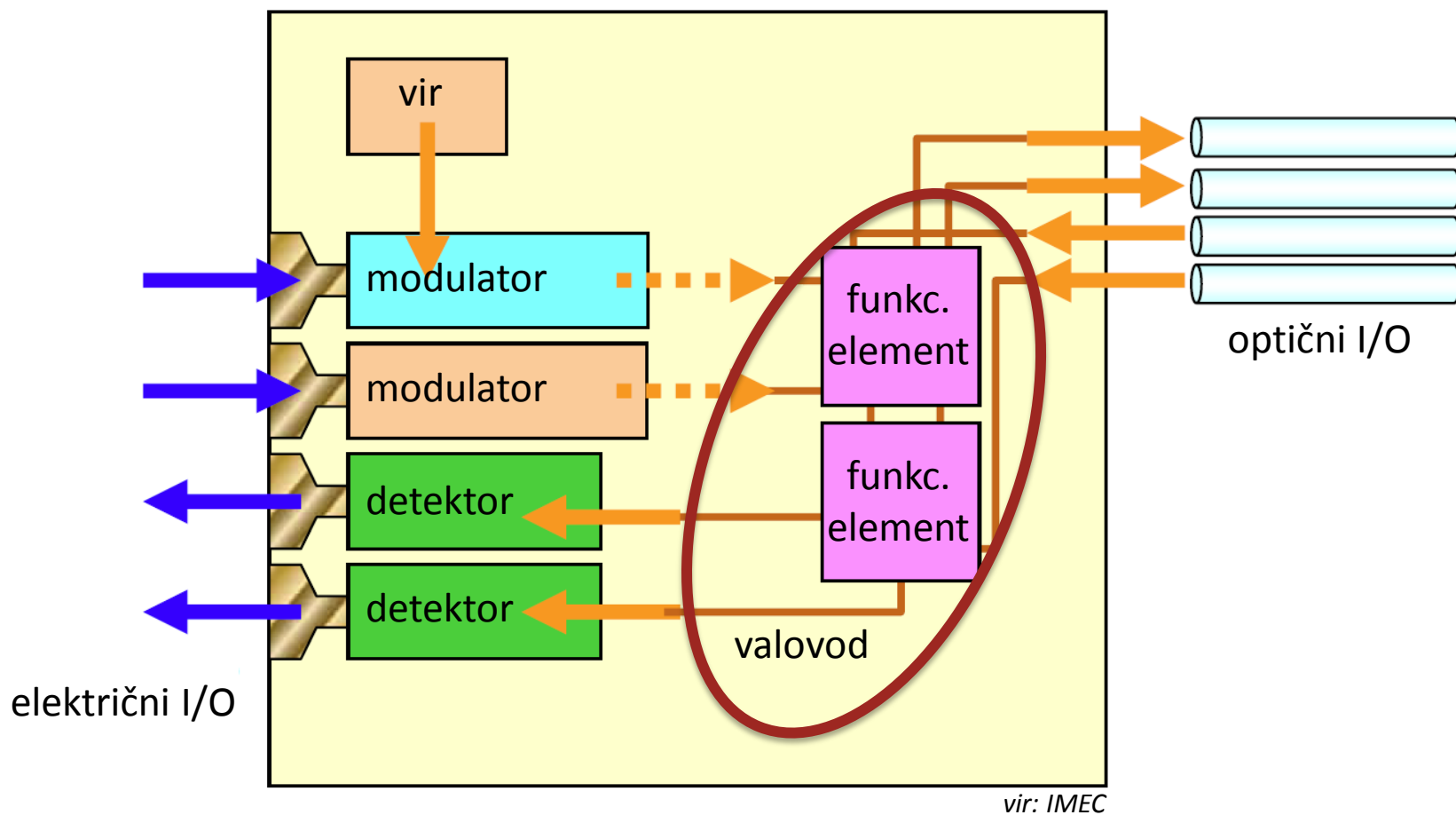

# Svetloba in snov

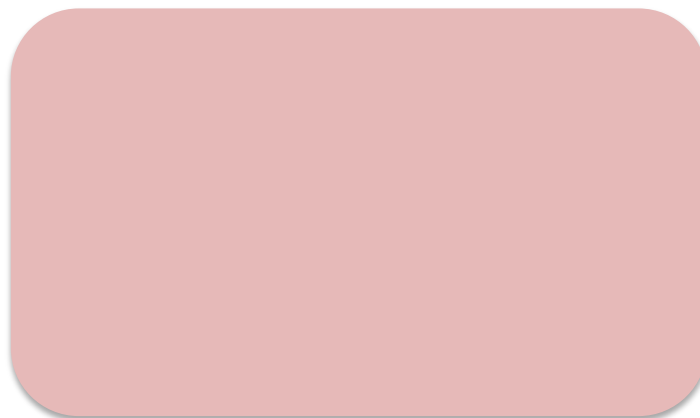

# Svetloba in snov

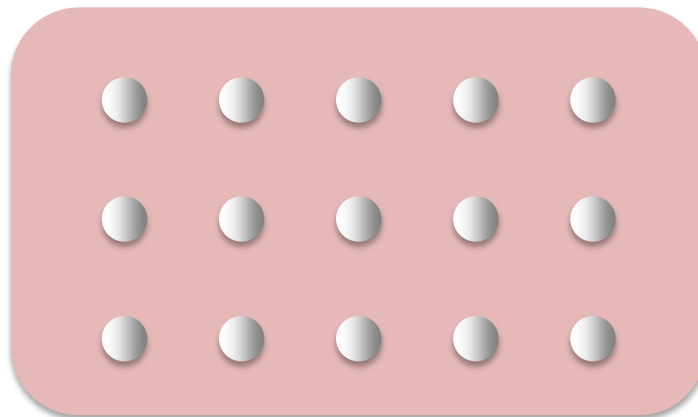

# Svetloba in snov

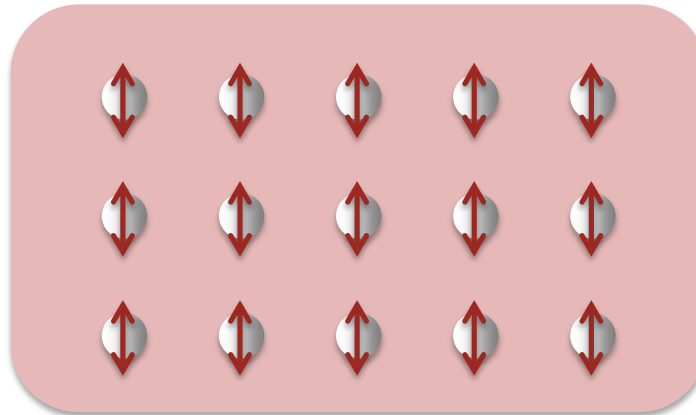
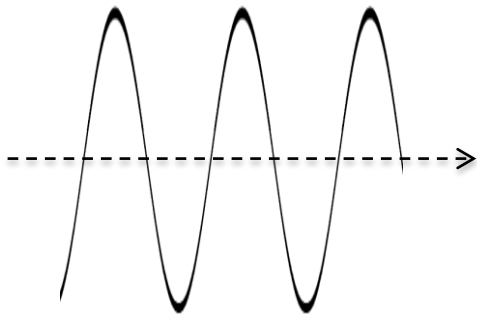

# Svetloba in snov

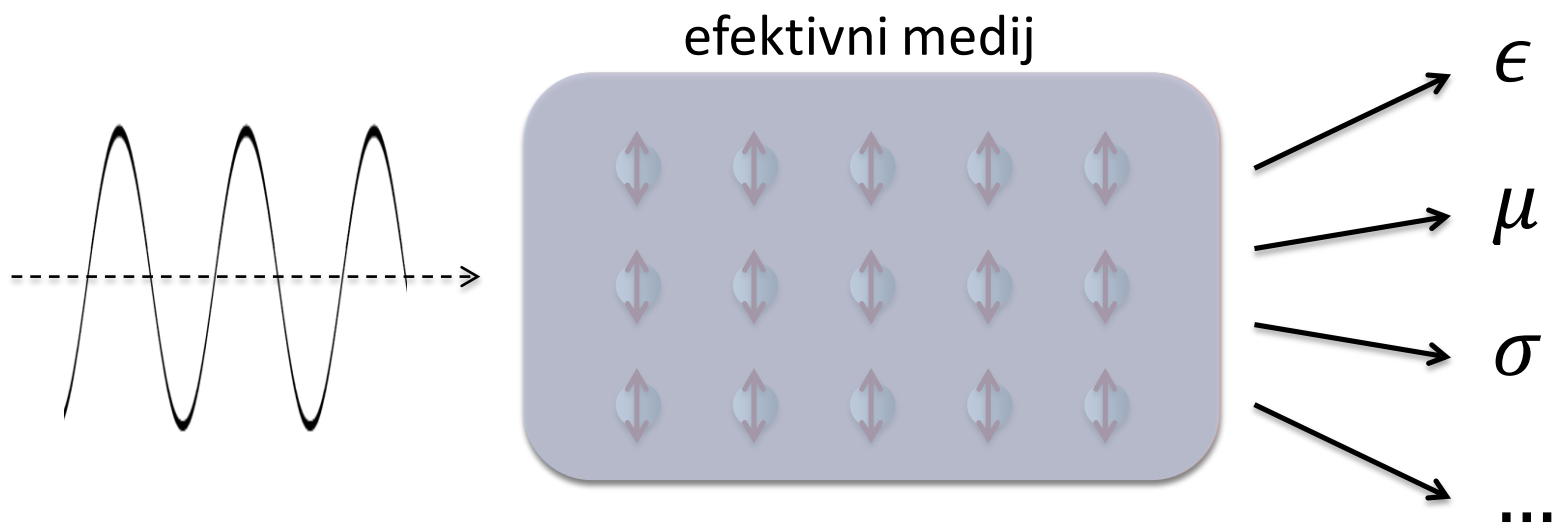

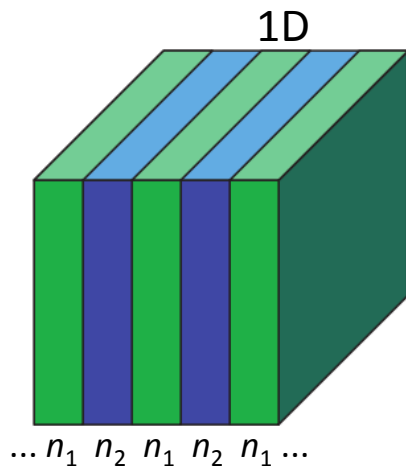

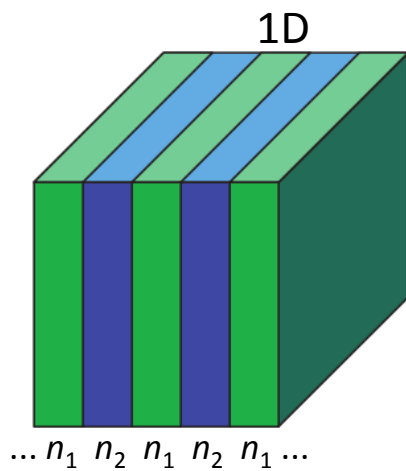

...  $n_1$   $n_2$   $n_1$   $n_2$   $n_1$  ...

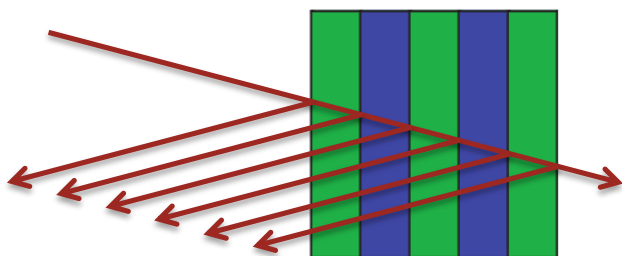

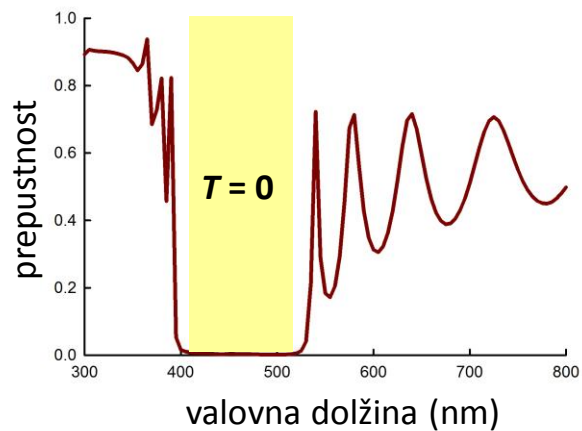
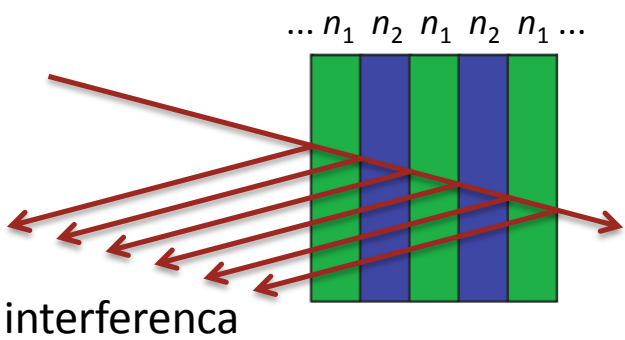
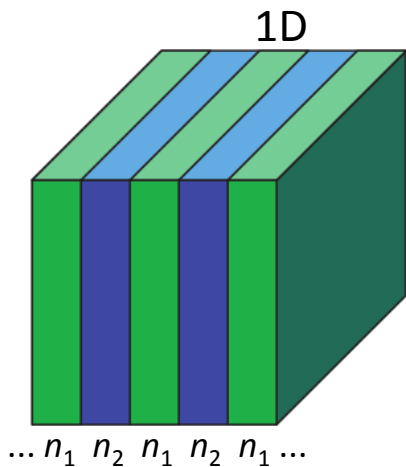



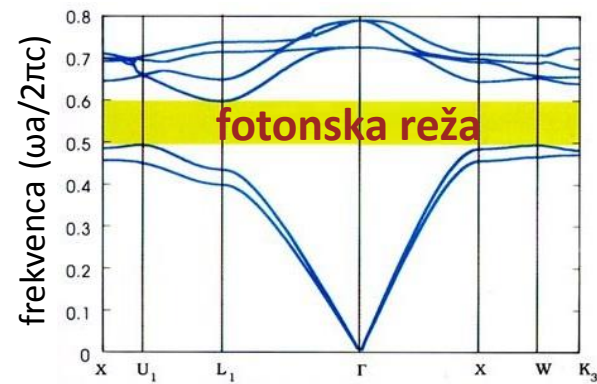
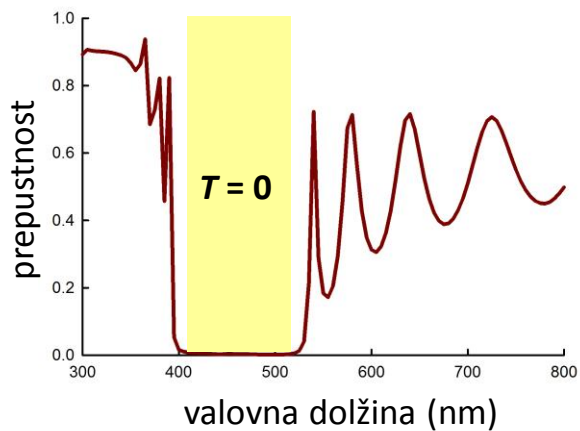
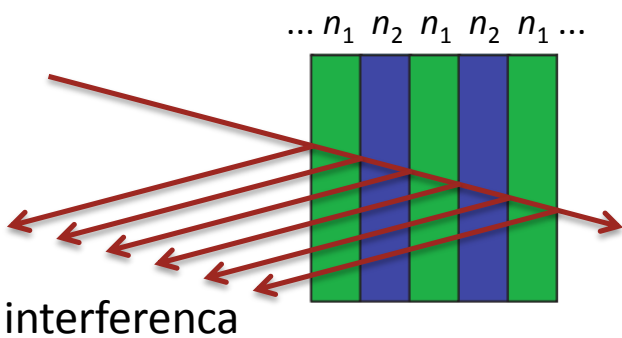
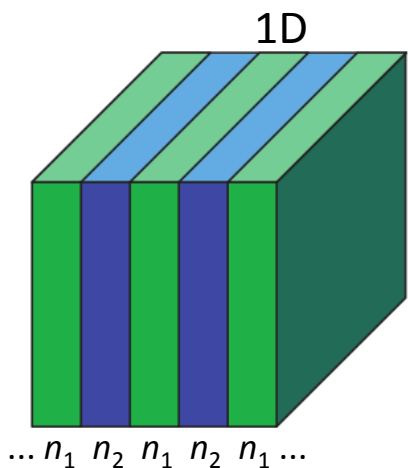

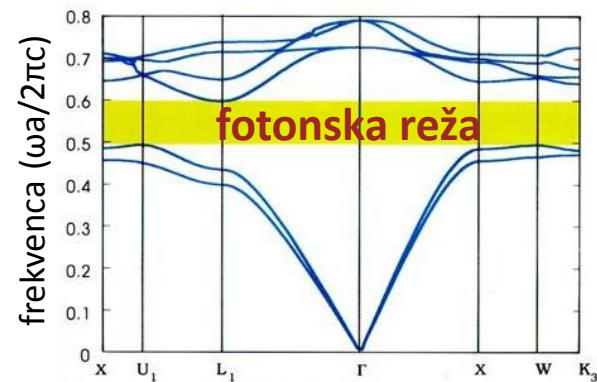
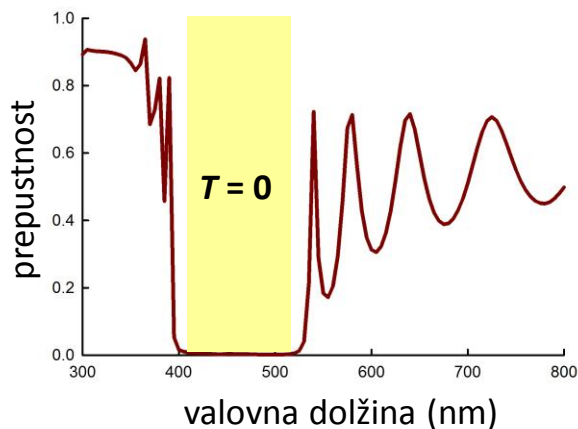
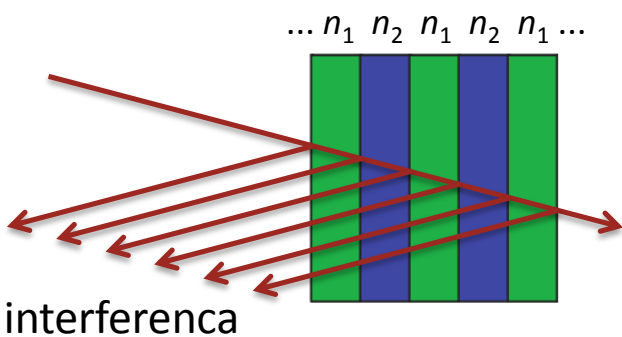
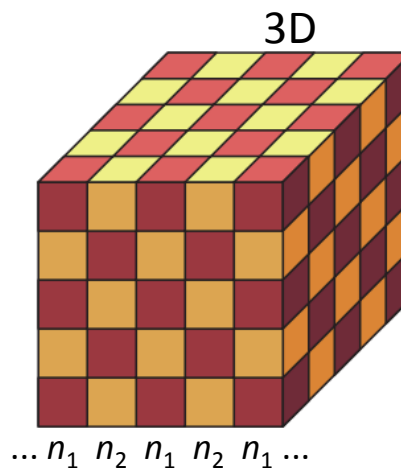
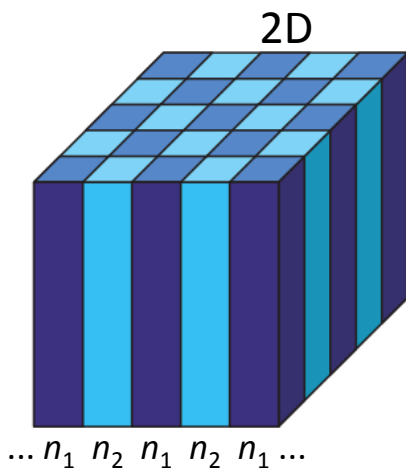
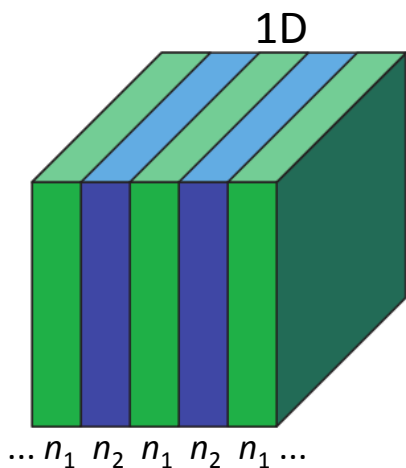

# Fotonski kristali (PC)

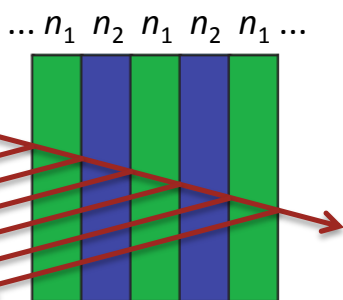
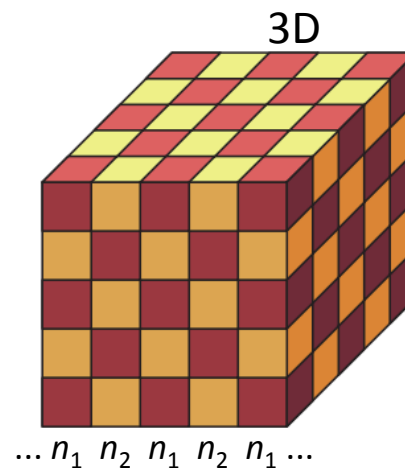
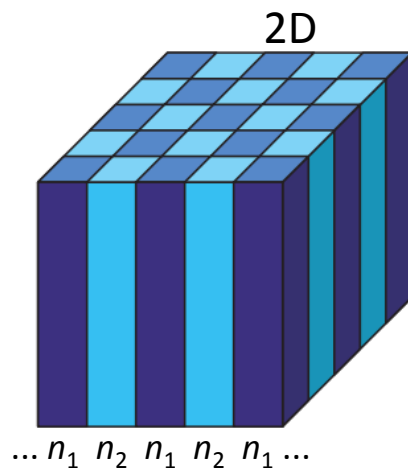
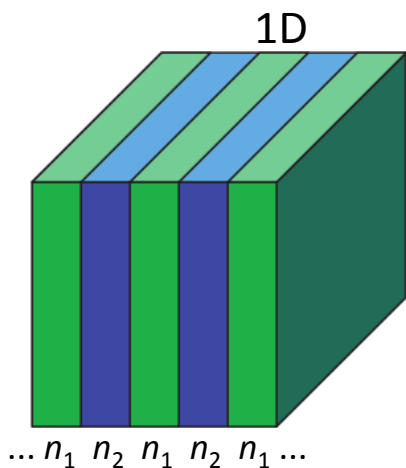

interferenca

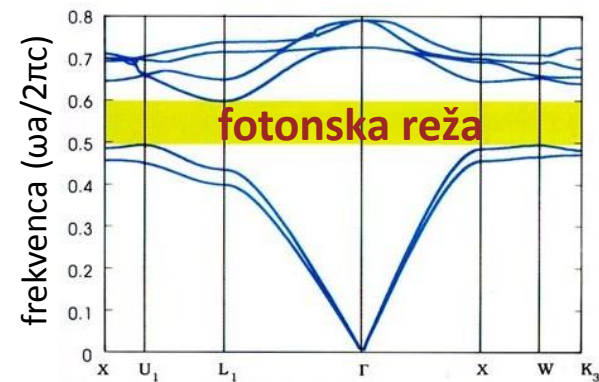
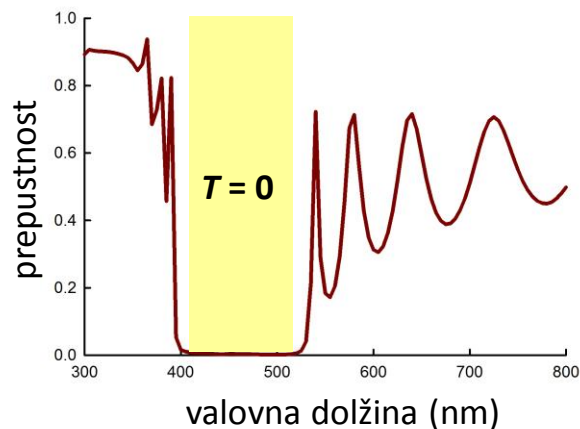

# Fotonski kristali – nov koncept?



# Fotonski kristali – nov koncept?

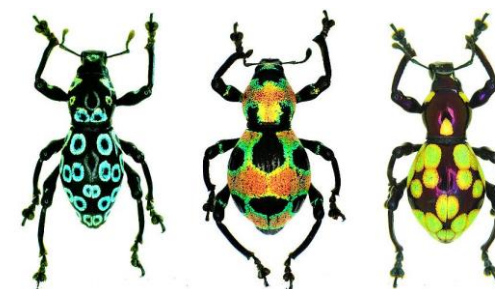
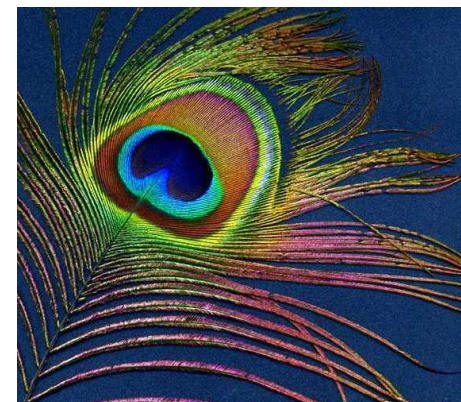
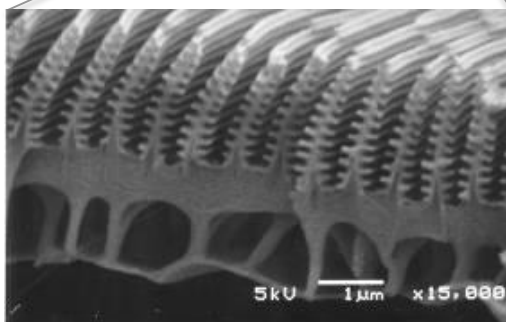
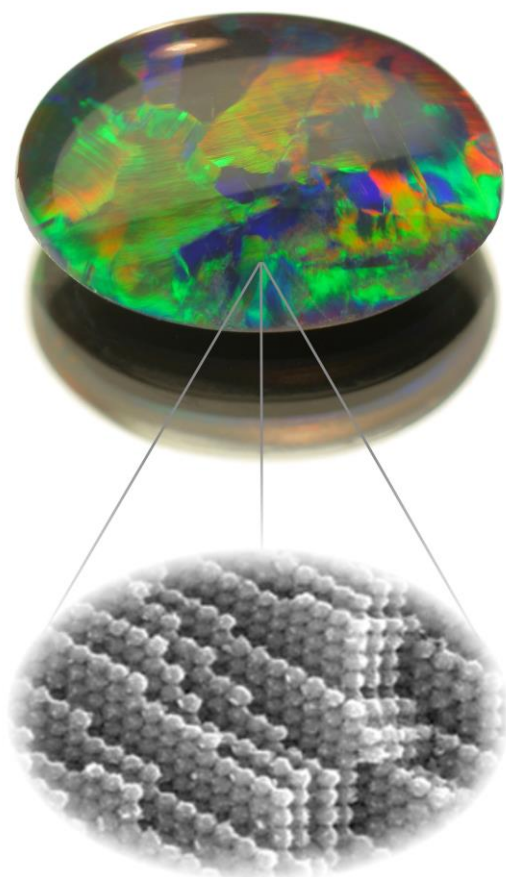

# Fotonsko kristalni valovodi (svetlovodi)

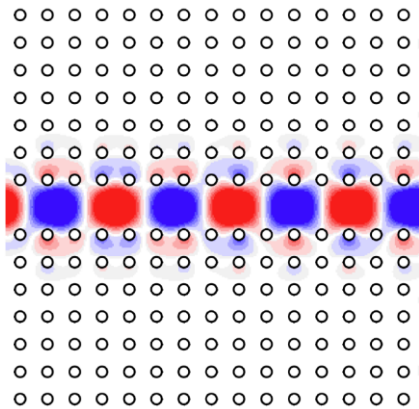

a) valovod

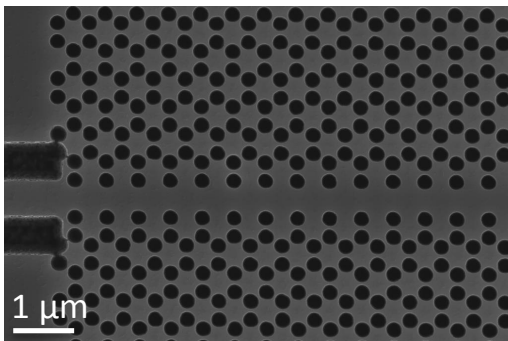

# Fotonsko kristalni valovodi (svetlovodi)

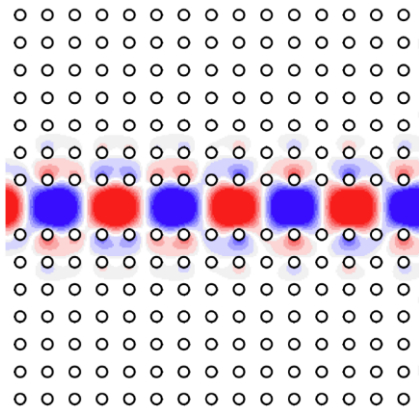

a) valovod

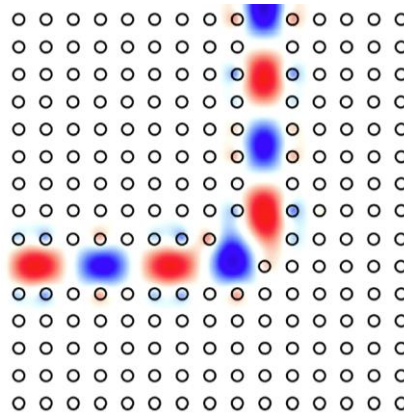

b) idealni 90° zavojev

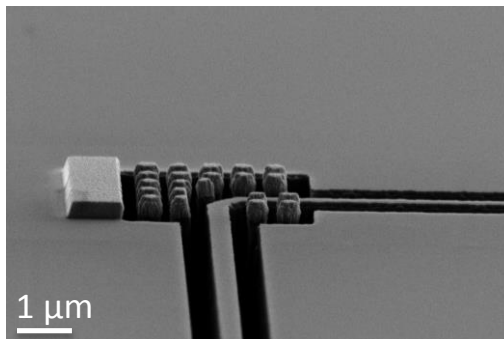
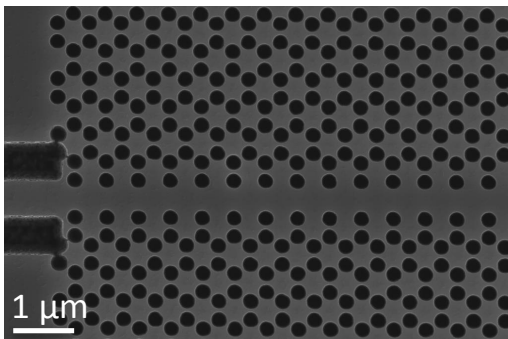

# Fotonsko kristalni valovodi (svetlovodi)

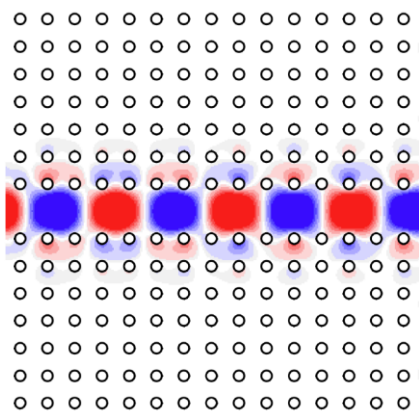

a) valovod

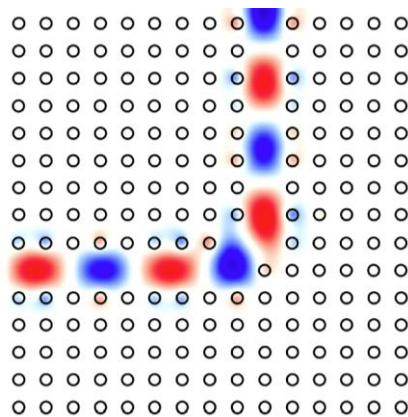

b) idealni 90° zavoje

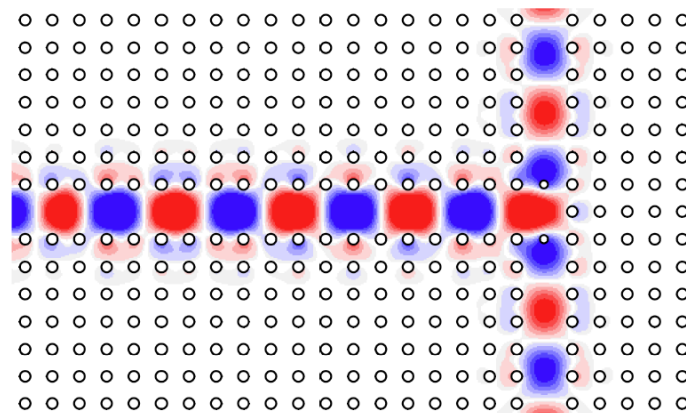

c) delilnik žarka

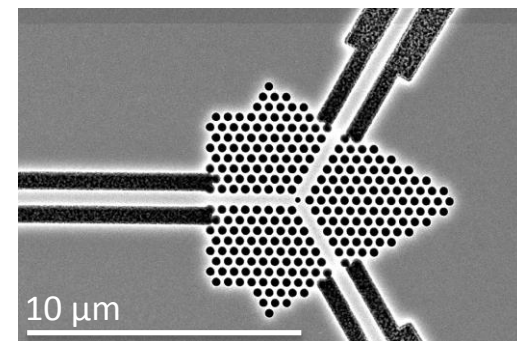
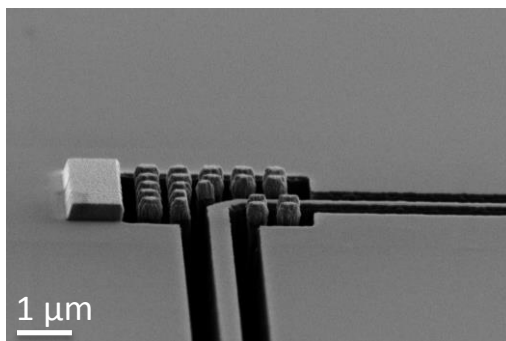
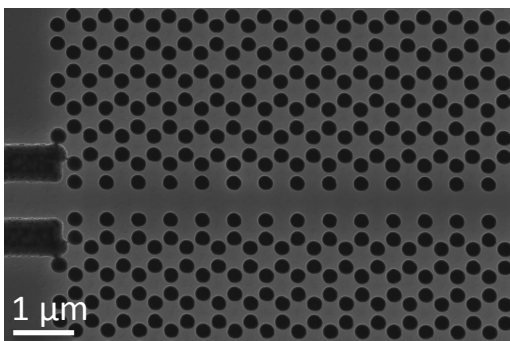

vir: ETH, Zürich



# Fotonsko kristalni valovodi (svetlovodi)

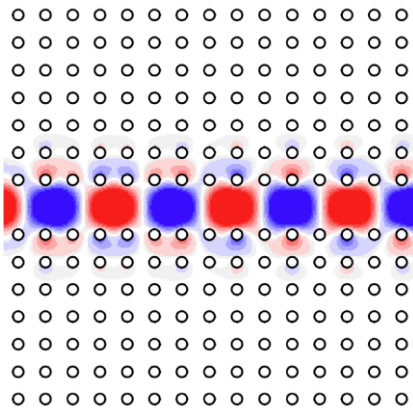

a) valovod

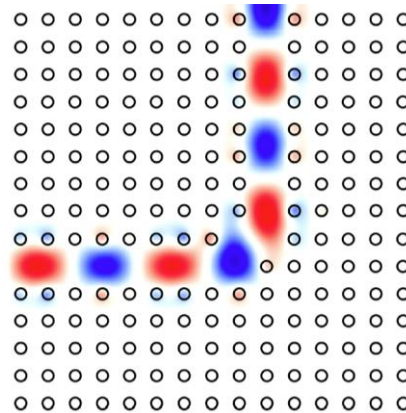

b) idealni 90° zavoj

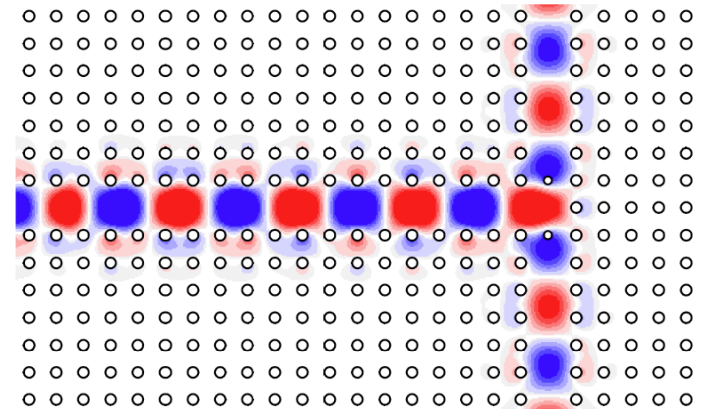

c) delilnik žarka

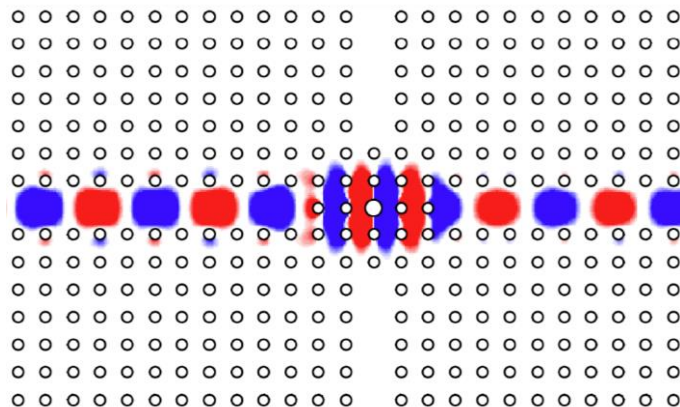

d) križanje valovodov brez motenj

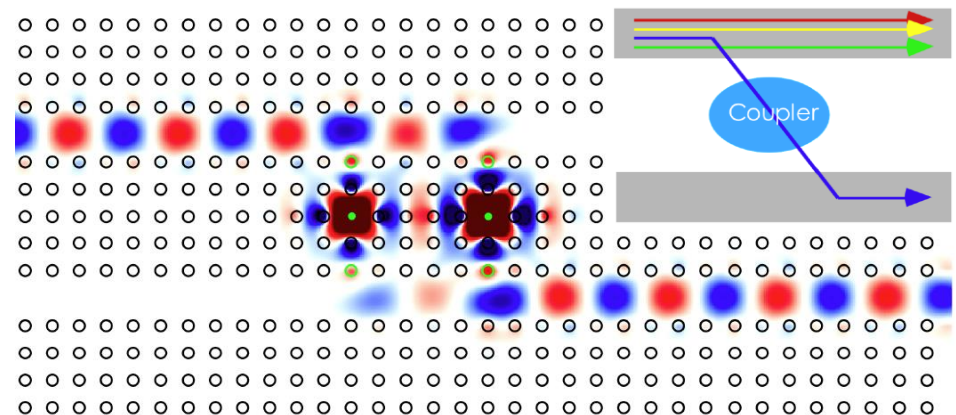

e) filtriranje komponent („channel drop filter“)

# Fotonsko kristalna optična vlakna (PCF)



▪

# Fotonsko kristalna optična vlakna (PCF)

## ▪ Izvedbe

- › Zračna sredica, obdana s koncentrično dielektrično PC strukturo
- › Zračna sredica, obdana z luknjičasto dielektrično PC strukturo
- › Dielektrična sredica, obdana z luknjičasto dielektrično PC strukturo

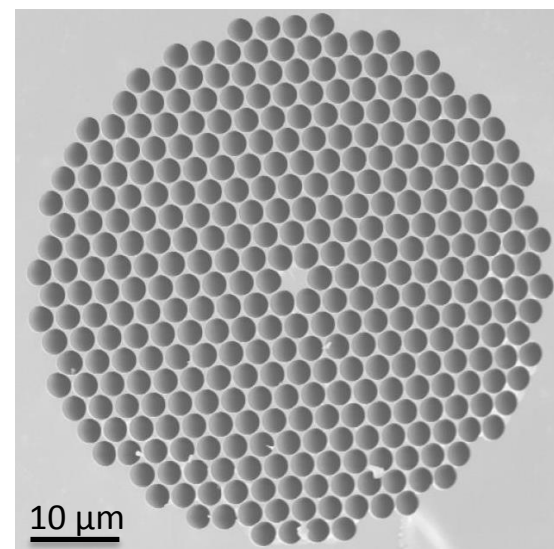
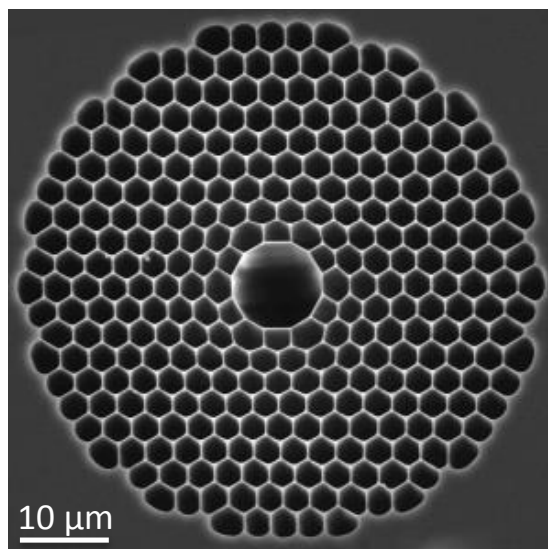
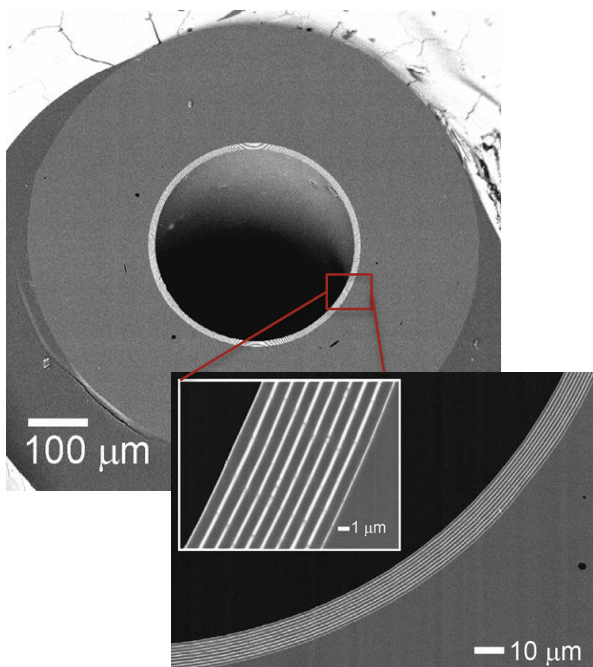

vir: MIT

# Razvrstitev materialov

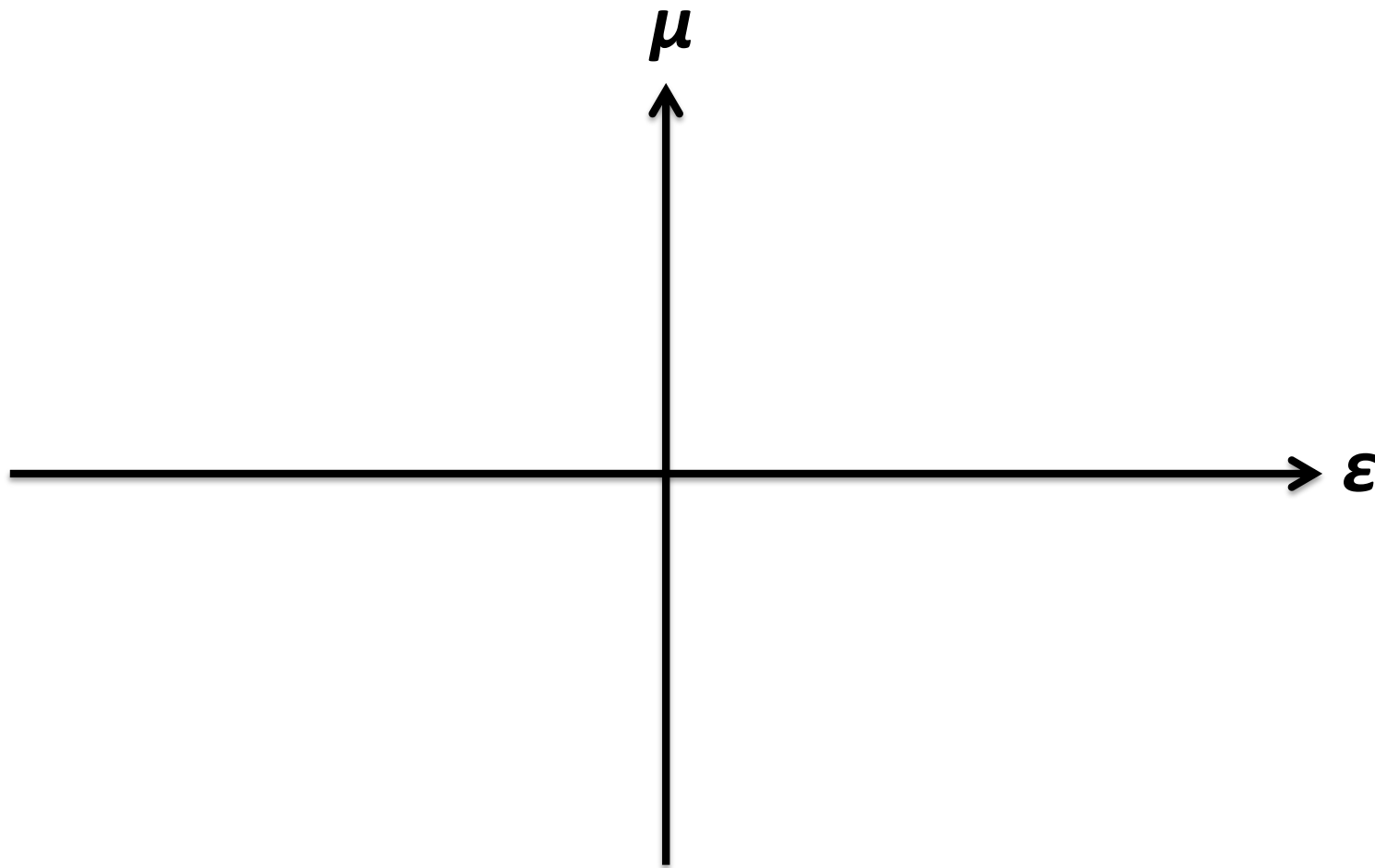

# Razvrstitev materialov

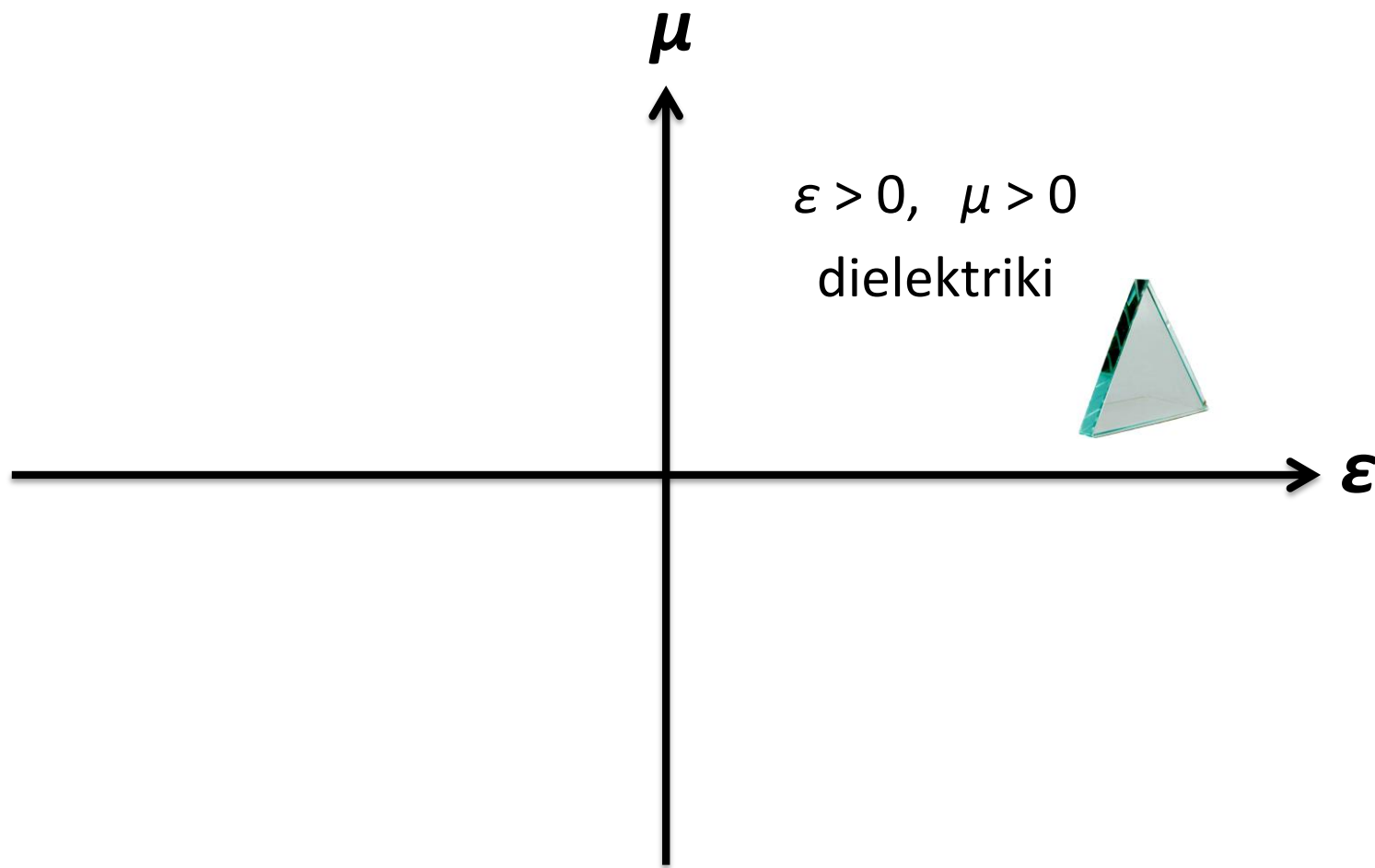

# Razvrstitev materialov

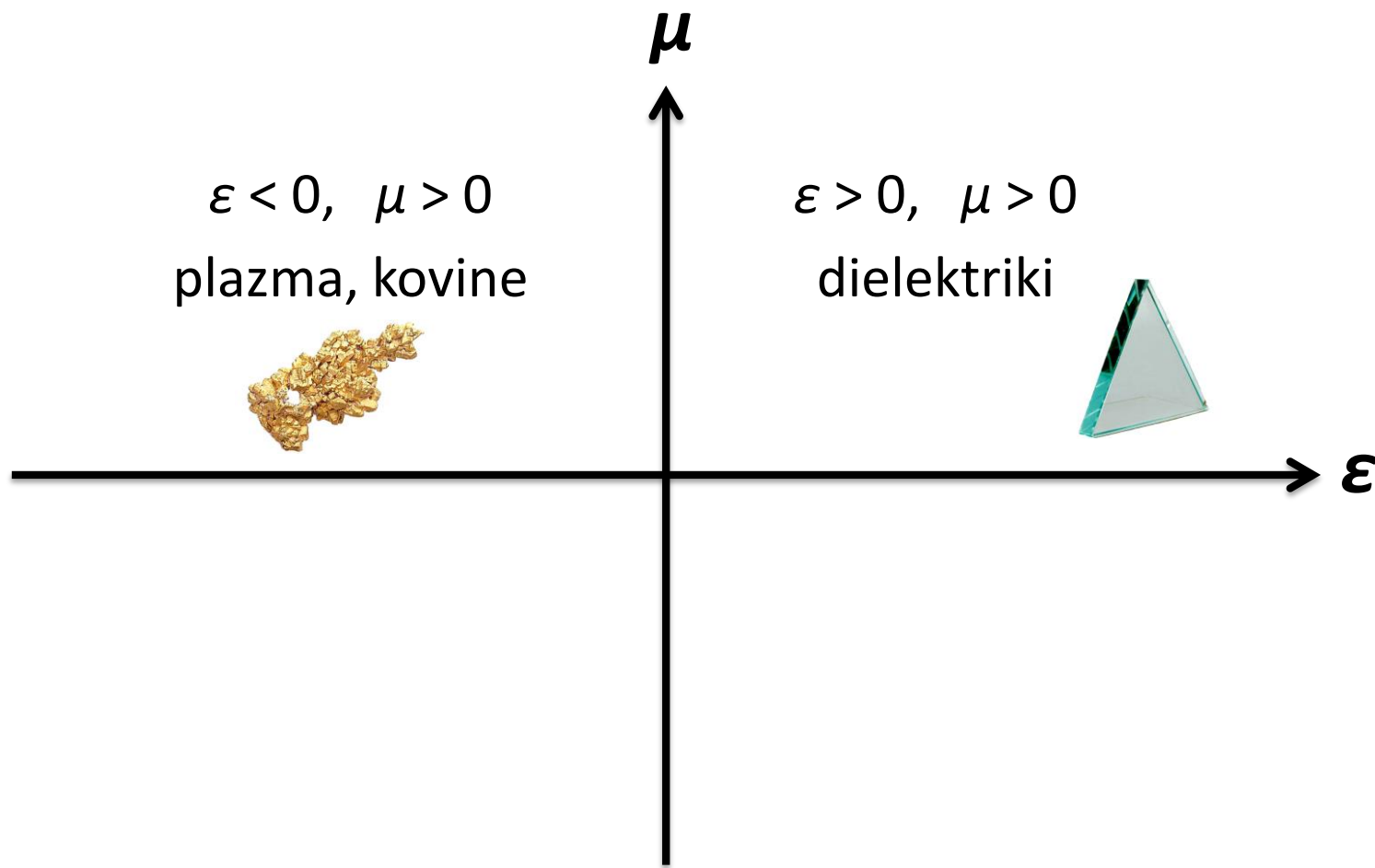

# Razvrstitev materialov

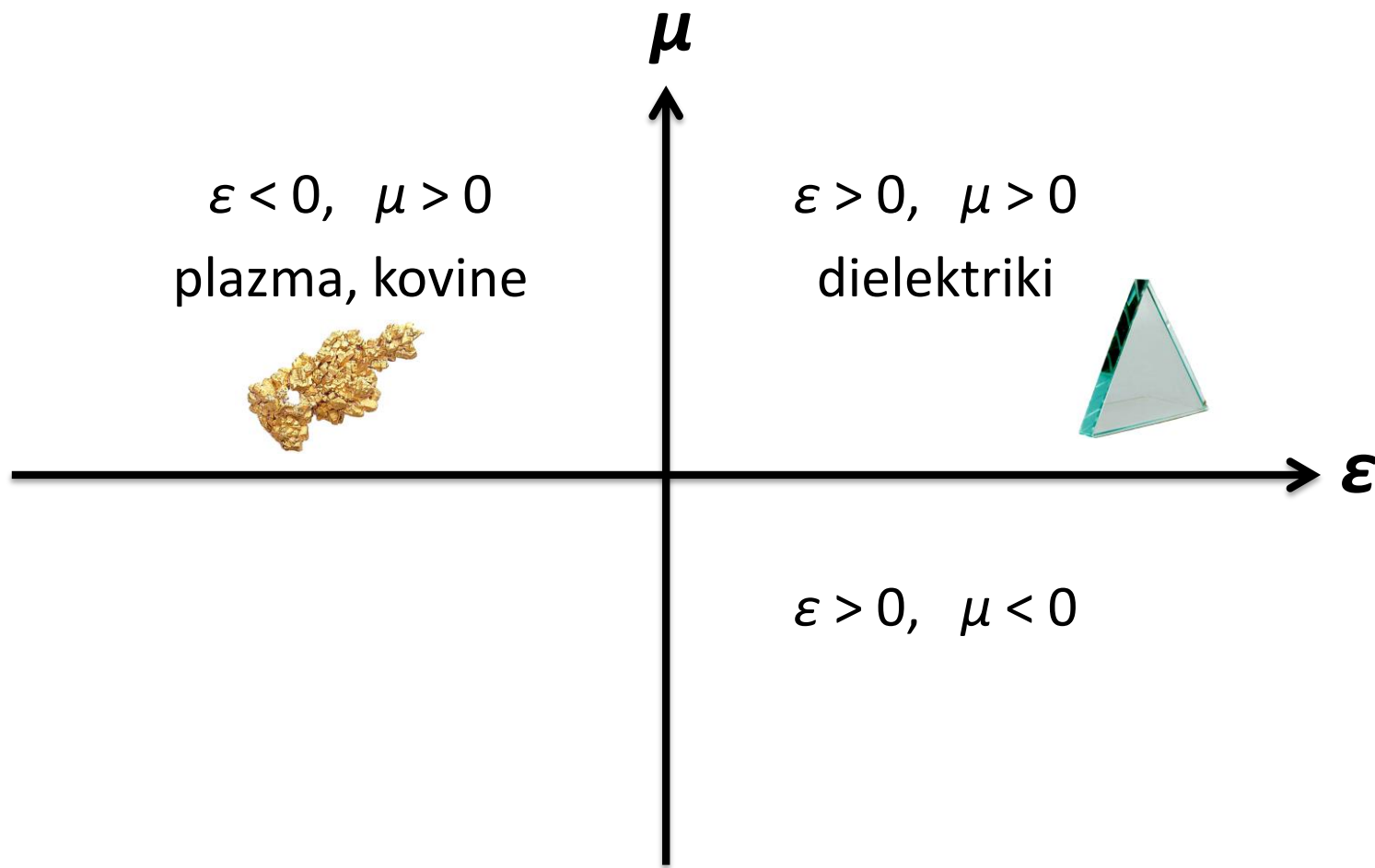

# Razvrstitev materialov

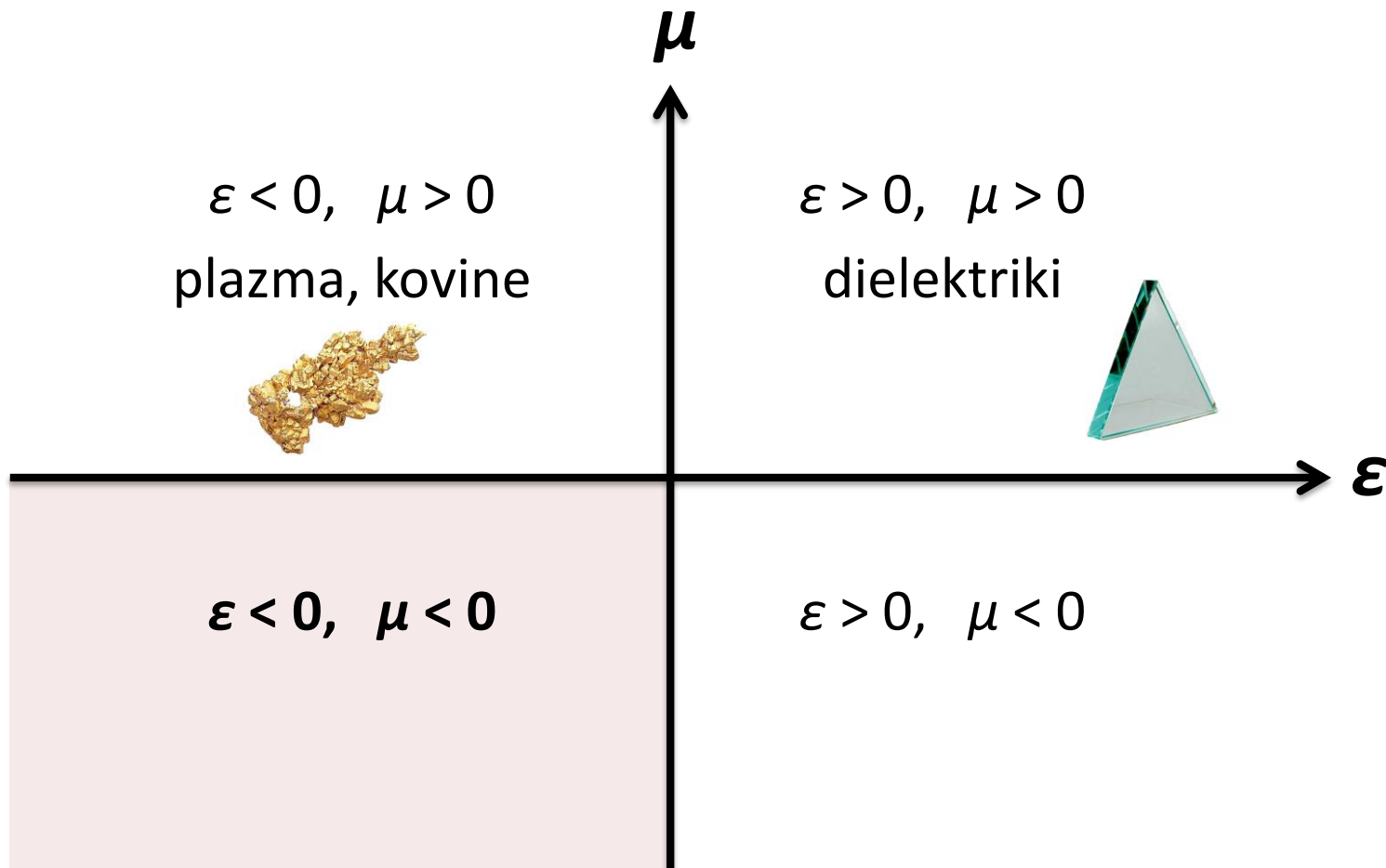



# Razvrstitev materialov

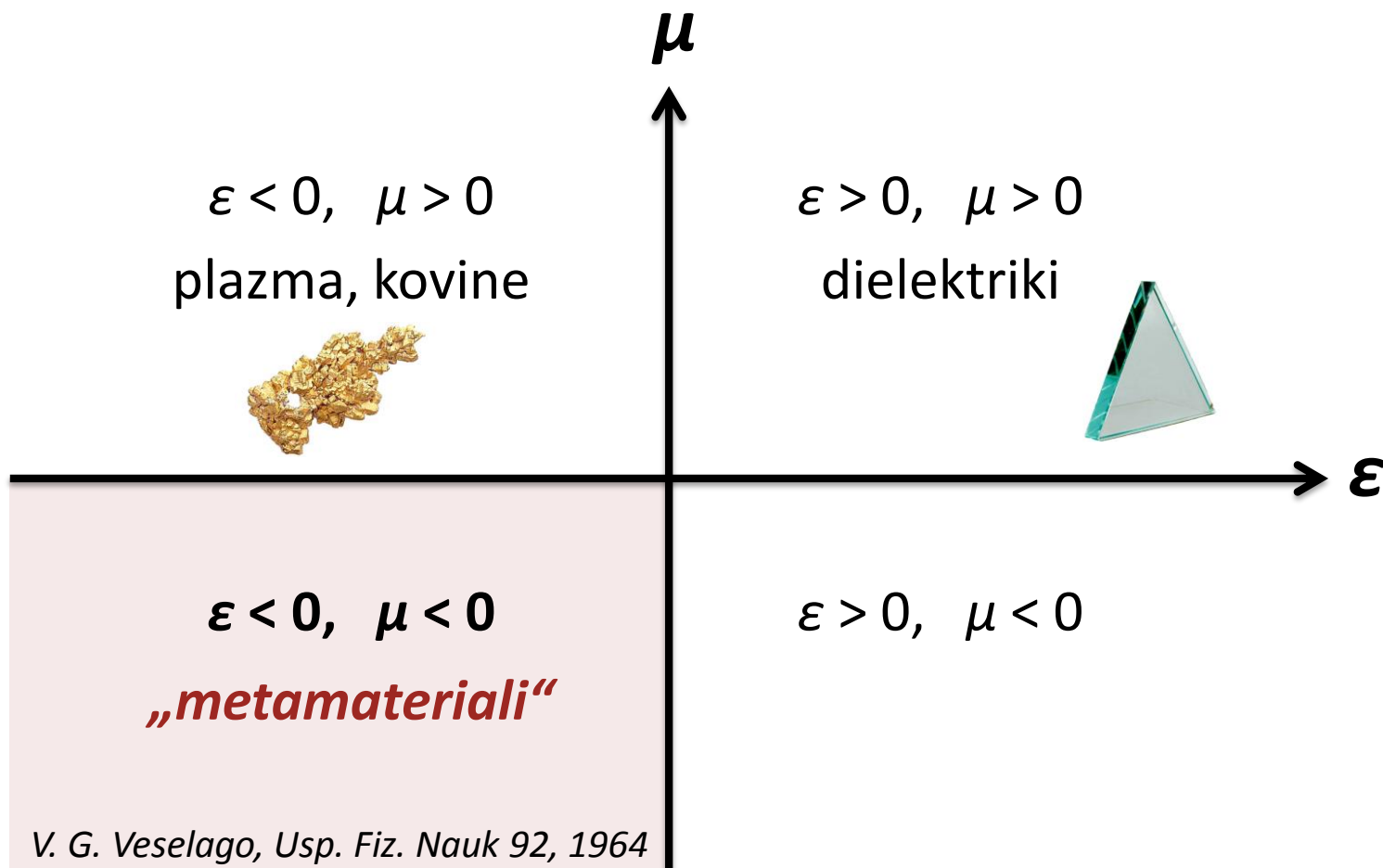

# Metamateriali in negativni lomni količnik

$$\frac{\sin \theta_1}{\sin \theta_2} = \frac{n_2}{n_1}$$

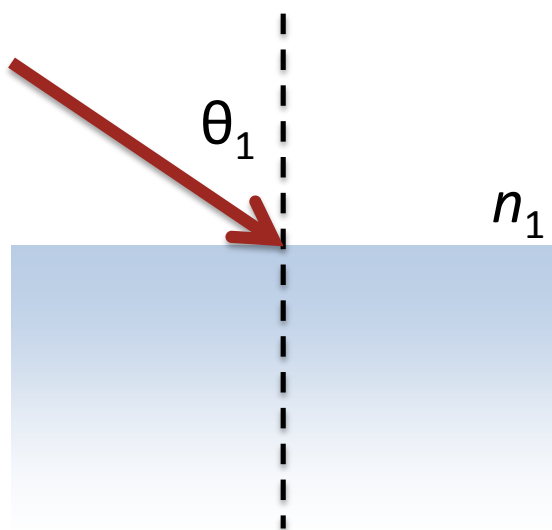

# Metamateriali in negativni lomni količnik

$$\frac{\sin \theta_1}{\sin \theta_2} = \frac{n_2}{n_1}$$

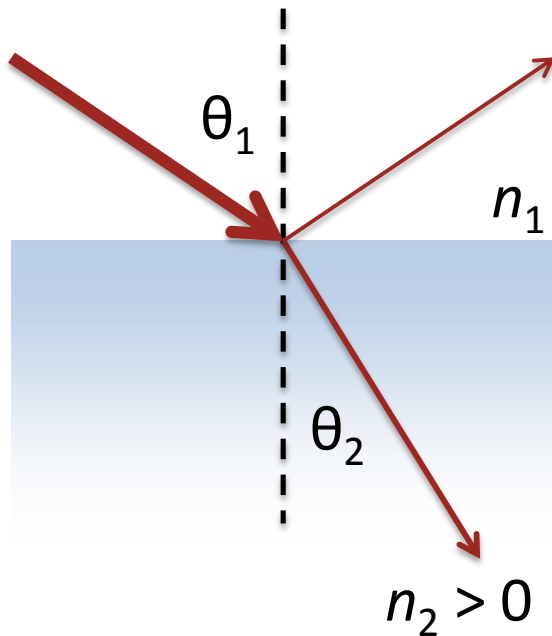

# Metamateriali in negativni lomni količnik

$$\frac{\sin \theta_1}{\sin \theta_2} = \frac{n_2}{n_1}$$

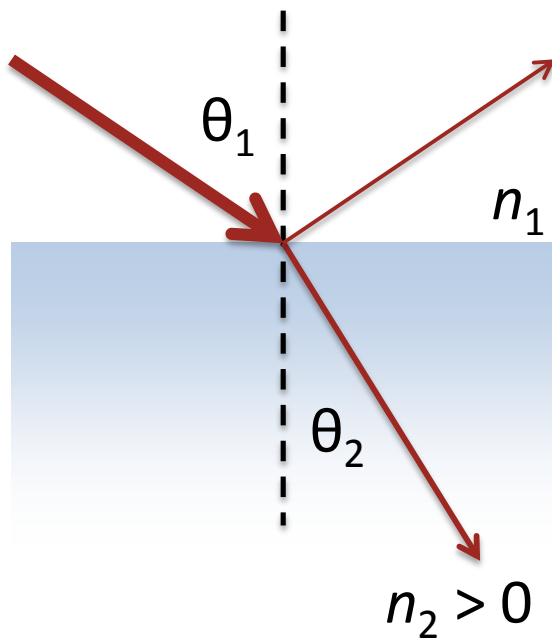

$n > 0$



# Metamateriali in negativni lomni količnik

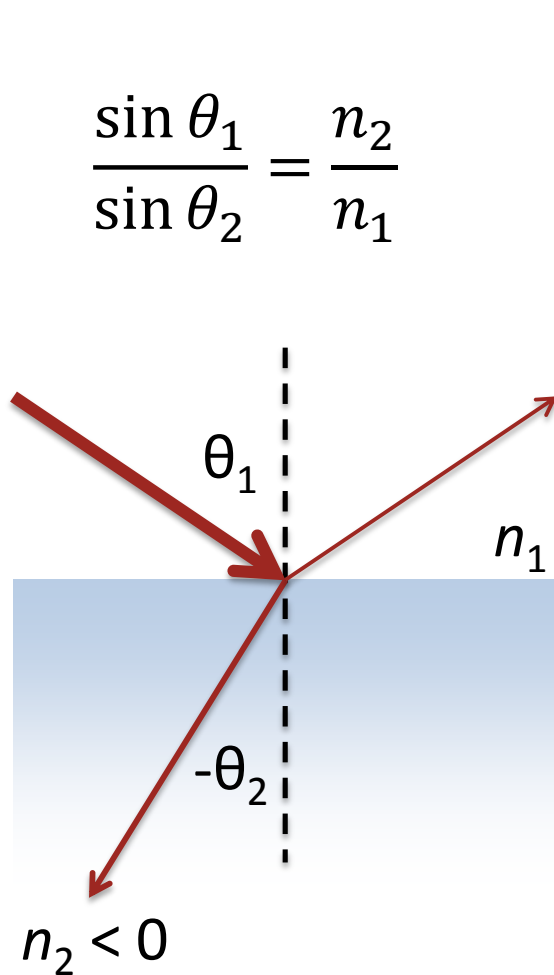

$n > 0$



# Metamateriali in negativni lomni količnik

$$\frac{\sin \theta_1}{\sin \theta_2} = \frac{n_2}{n_1}$$

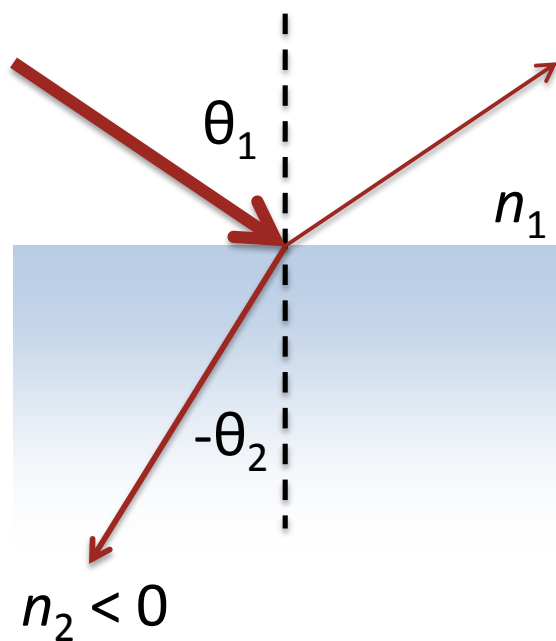

$n > 0$



$n < 0$



vir: TU Wien

# Metamateriali v mikrovalovnem območju

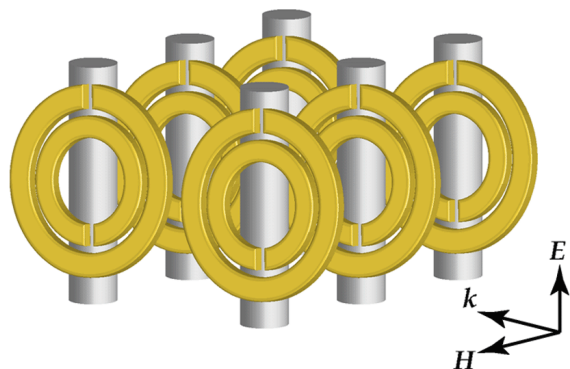

vir: Pendry, *IEEE T. Microw. Theory* 47, 1999

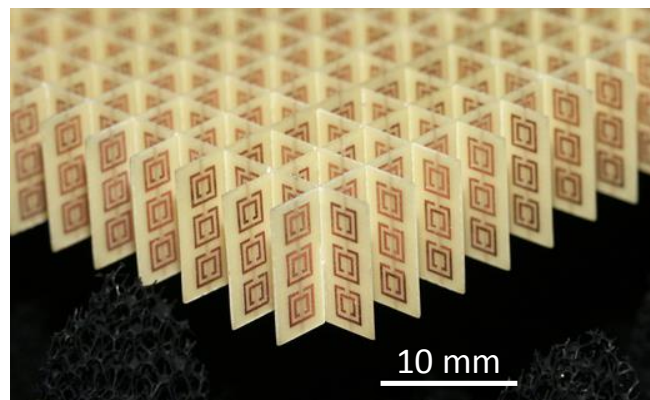

vir: Smith, *Phys. Rev. Lett* 84, 2001

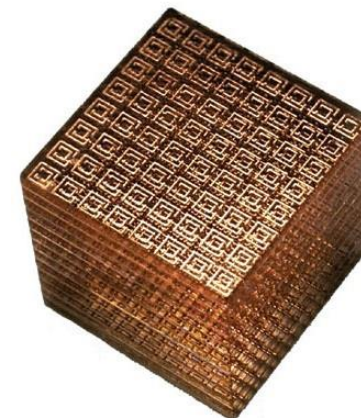

vir: Pendry, *Physics Today*, 2003

# Metamateriali v mikrovalovnem območju

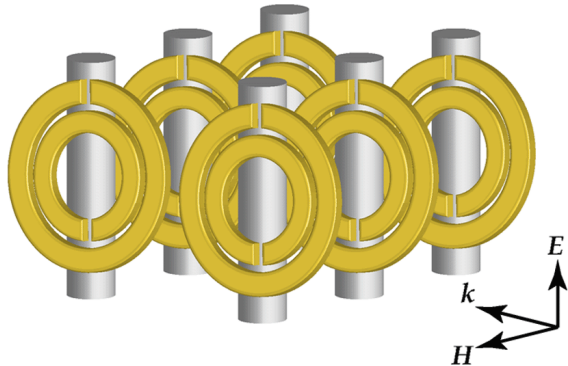

vir: Pendry, *IEEE T. Microw. Theory* 47, 1999

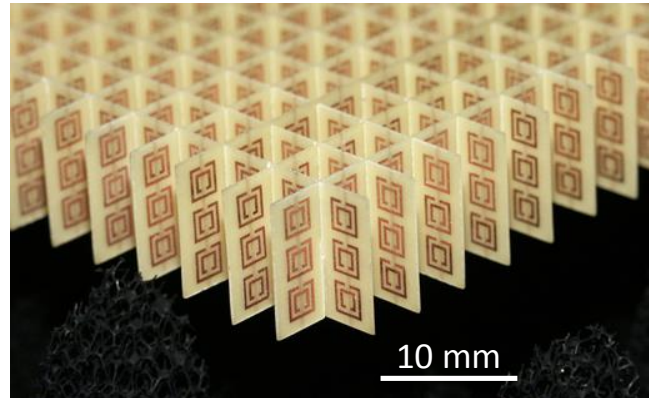

vir: Smith, *Phys. Rev. Lett* 84, 2001

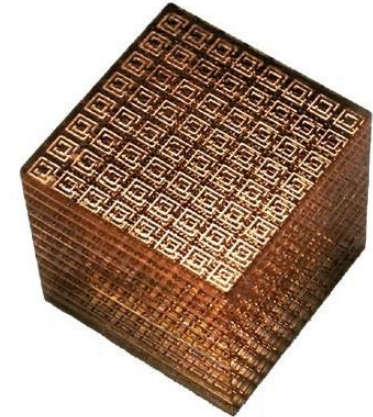

vir: Pendry, *Physics Today*, 2003

## ▪ Eksperiment pri 10.5 GHz

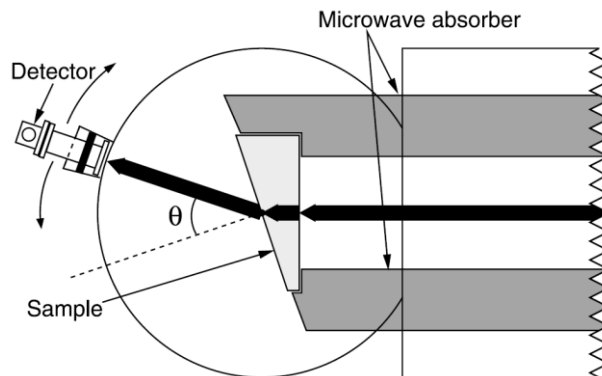
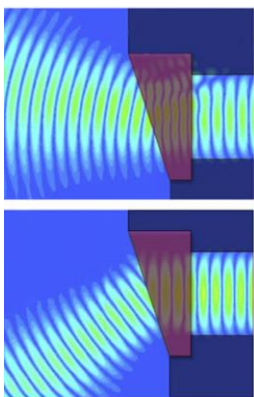

vir: Shelby, *Science* 292, 2001

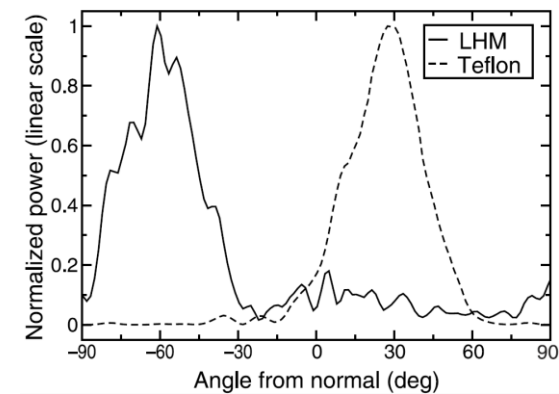



# Metamateriali v nanovalovnem območju

## ■ Izzivi

- › Izjemno majhne dimenzije osnovnih celic (manjše od valovne dolžine)
- › Potreba po 3D strukturah; zahtevna izdelava

# Metamateriali v nanovalovnem območju

## ■ Izzivi

- › Izjemno majhne dimenzije osnovnih celic (manjše od valovne dolžine)
- › Potreba po 3D strukturah; zahtevna izdelava

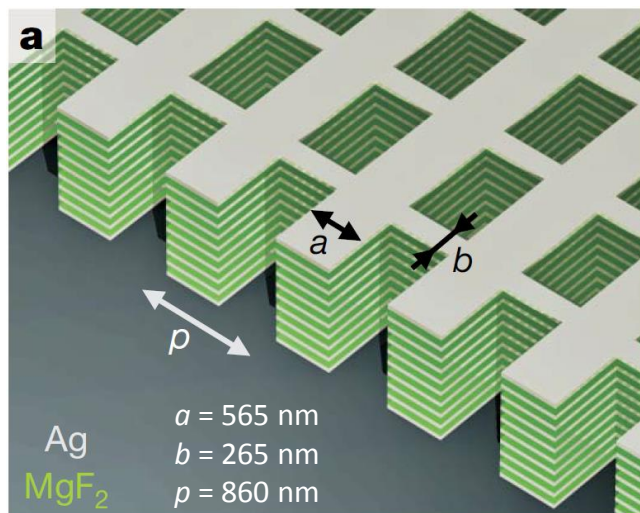

vir: Valentine, *Nature Letters* 455, 2008

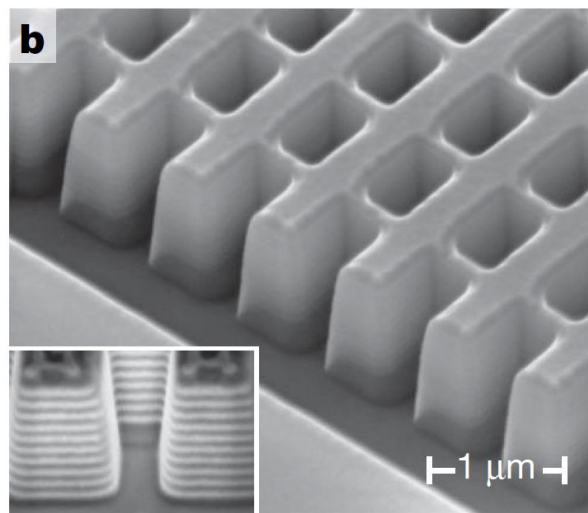

# Metamateriali v nanovalovnem območju

## ■ Izzivi

- › Izjemno majhne dimenzije osnovnih celic (manjše od valovne dolžine)
- › Potreba po 3D strukturah; zahtevna izdelava

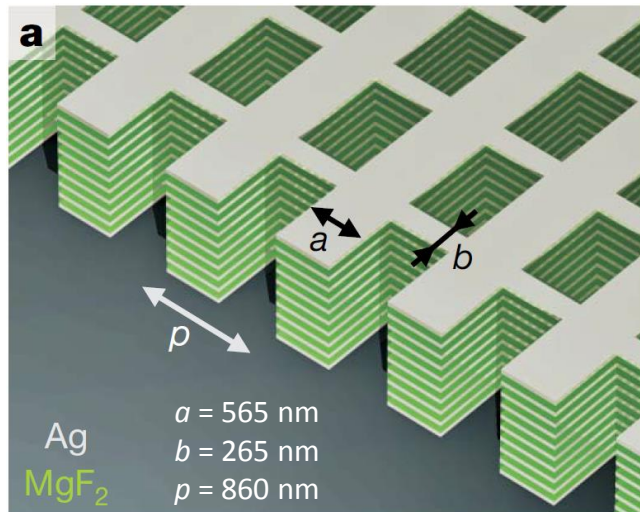

vir: Valentine, Nature Letters 455, 2008

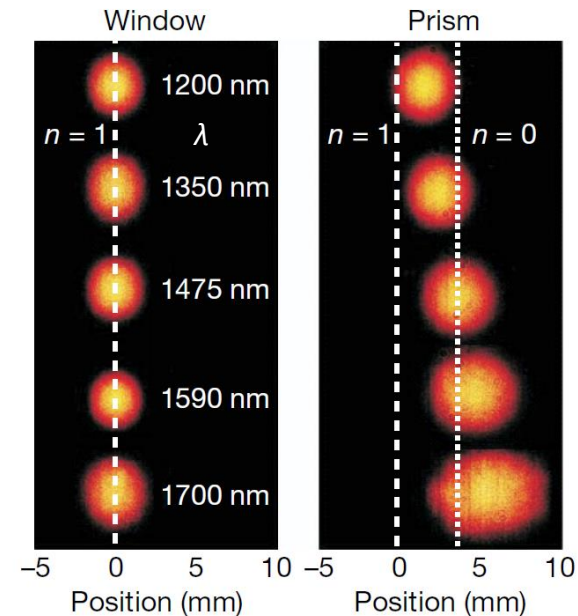
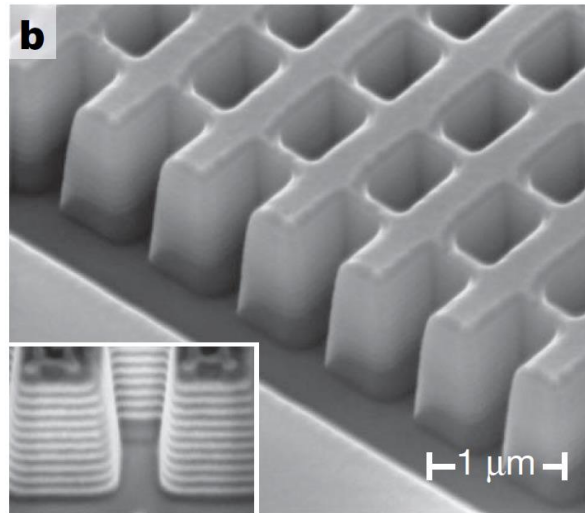

# Metamateriali v nanovalovnem območju

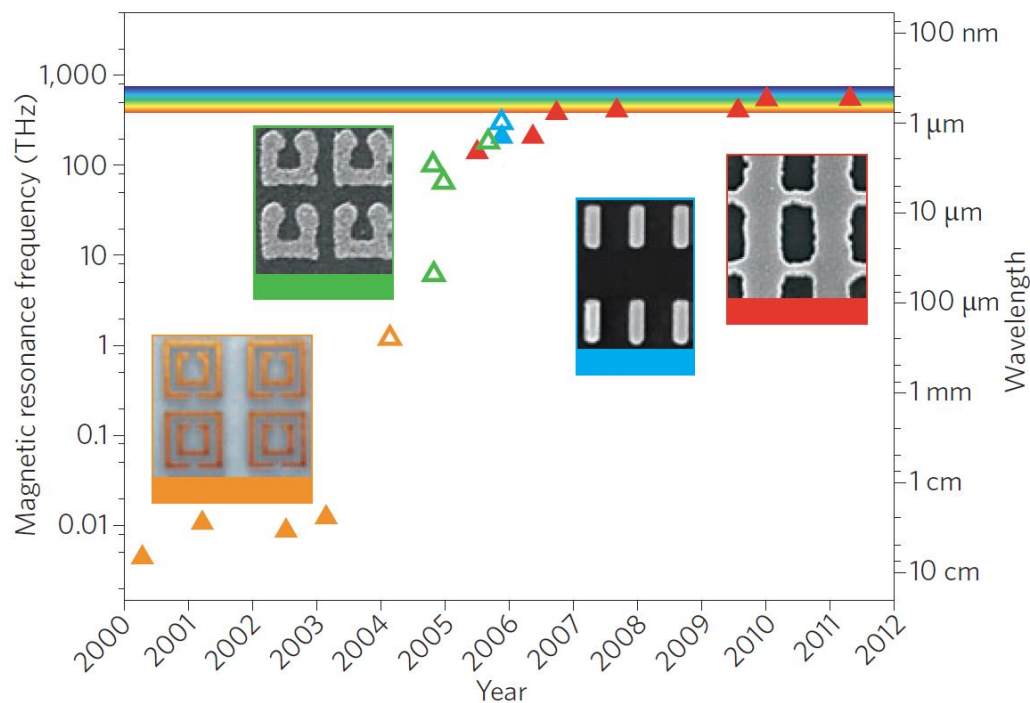

# Metamateriali v nanovalovnem območju

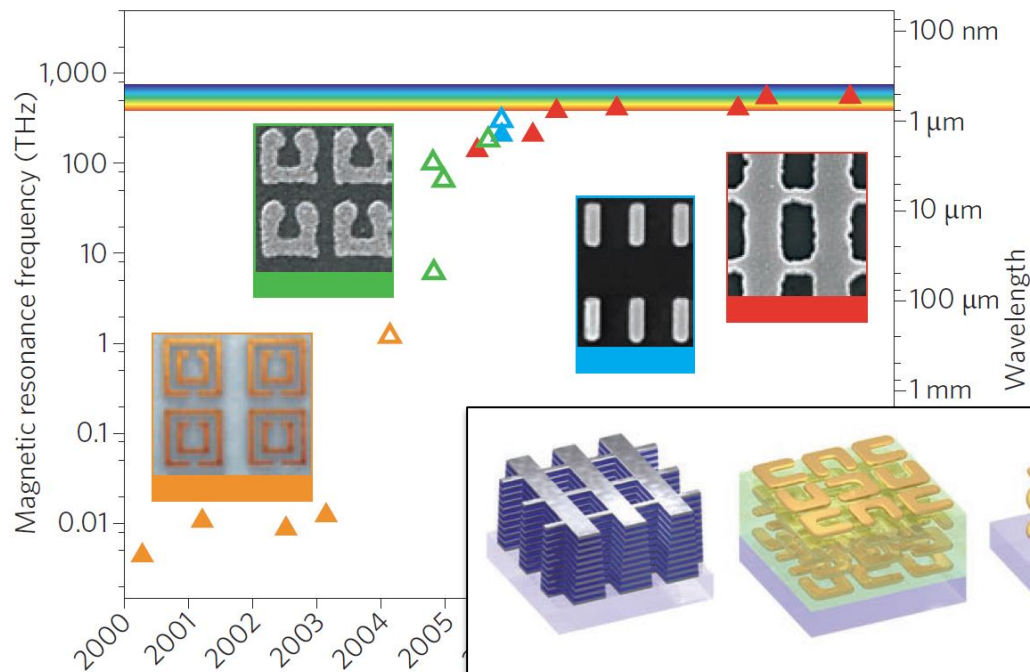

vir: Soukoulis, Nature Photonics, 2011

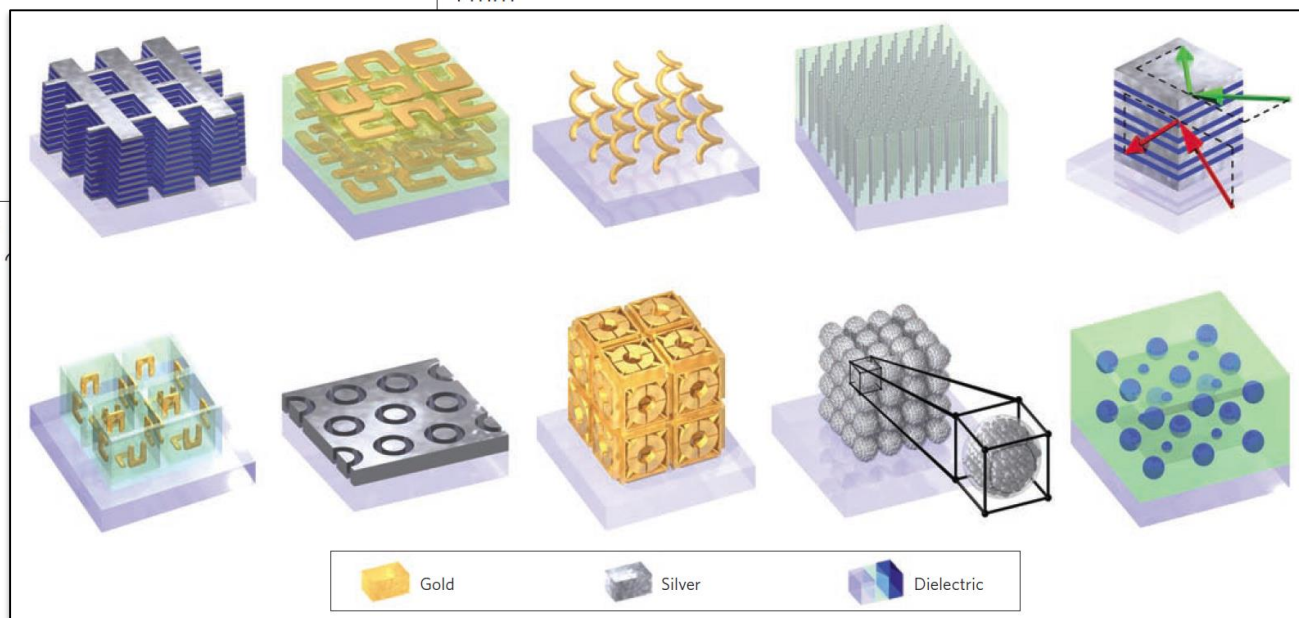

# Metamateriali – superleča

- Gorišče
- Ločljivost

# Metamateriali – superleča

- Gorišče

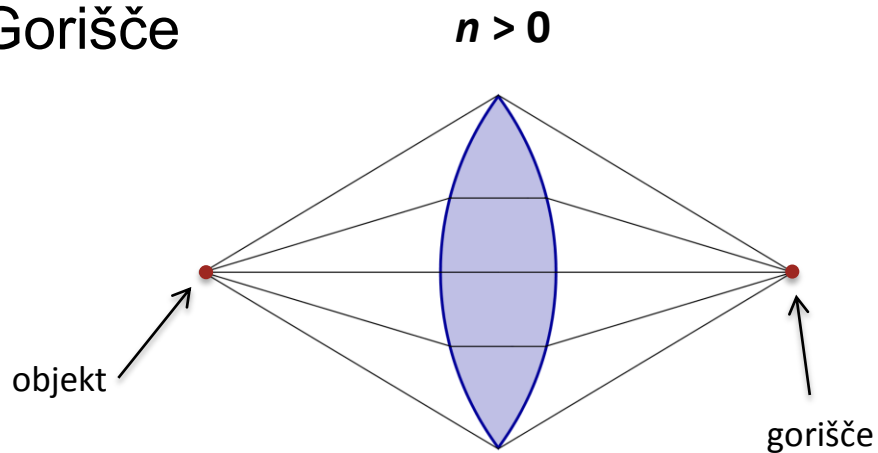

- Ločljivost

# Metamateriali – superleča

## ▪ Gorišče

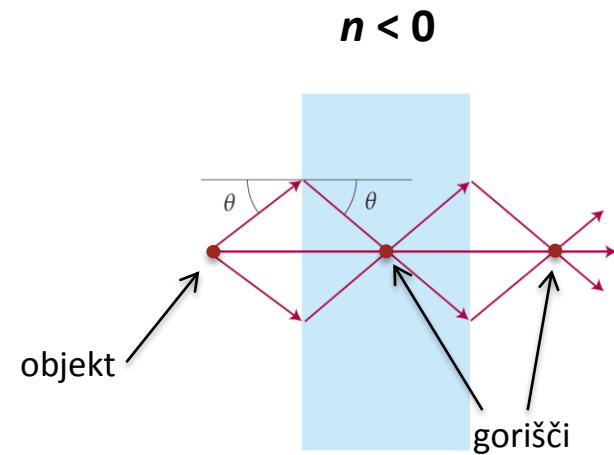
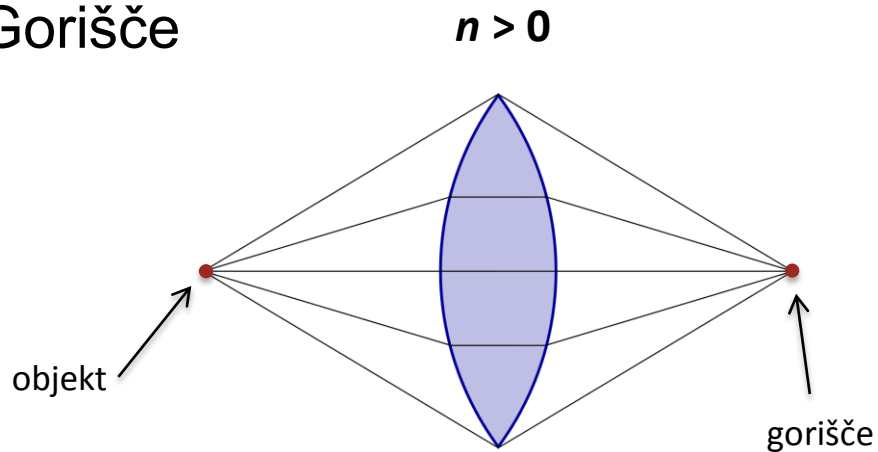

## ▪ Ločljivost



# Metamateriali – superleča

## ▪ Gorišče

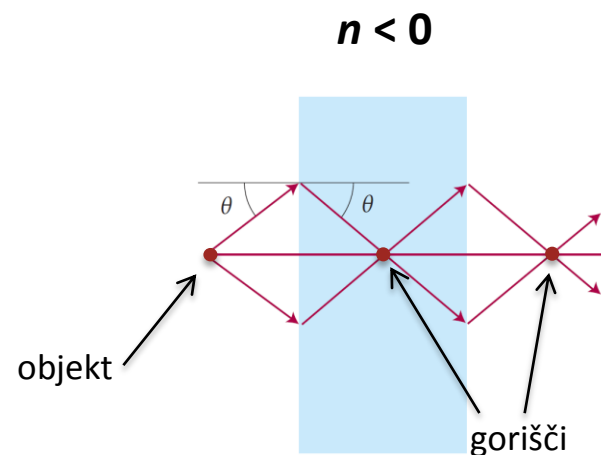
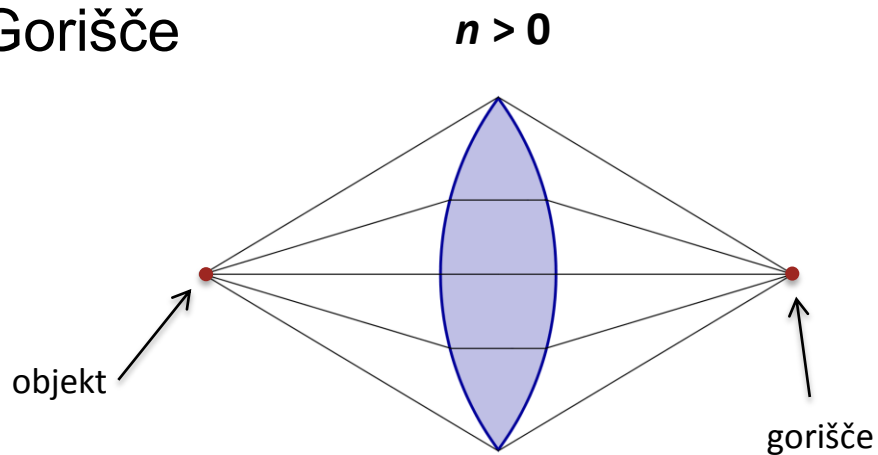

## ▪ Ločljivost

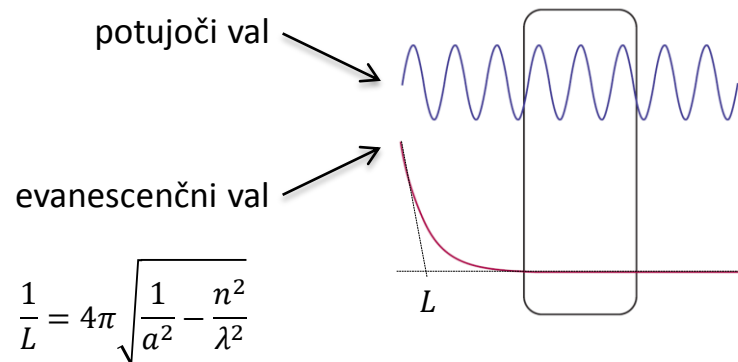

# Metamateriali – superleča

## ▪ Gorišče

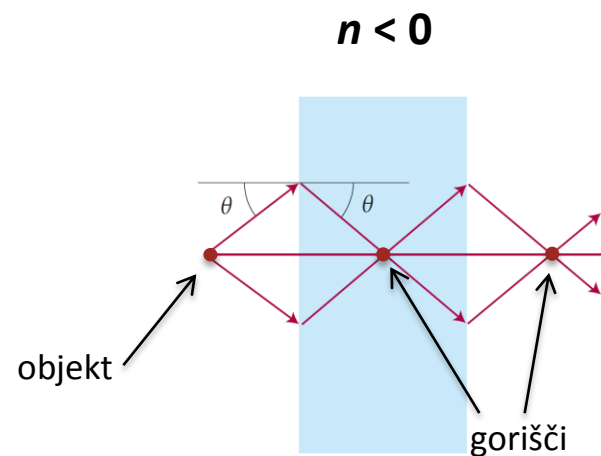
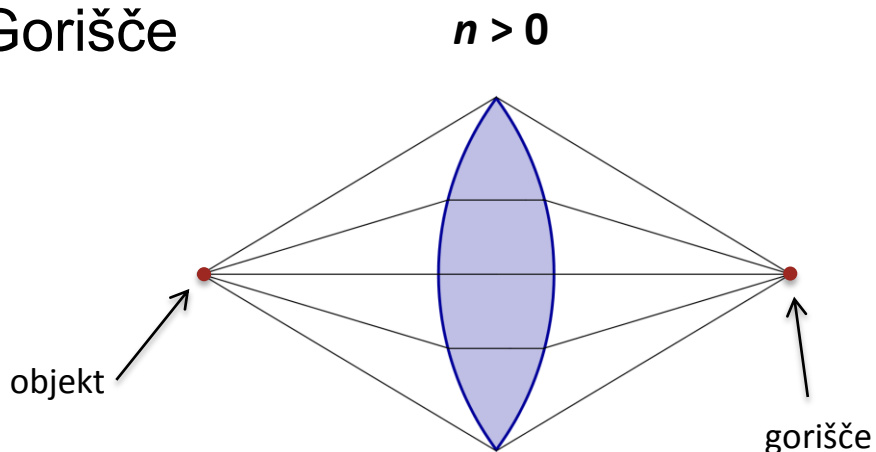

## ▪ Ločljivost

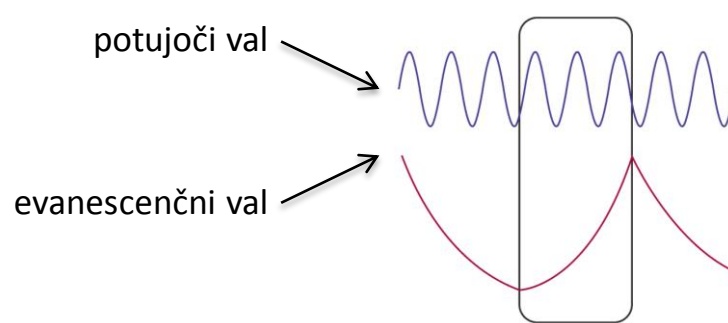
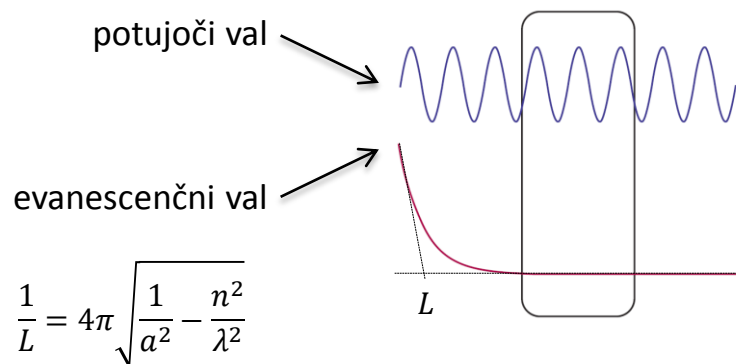

# Metamateriali – superleča

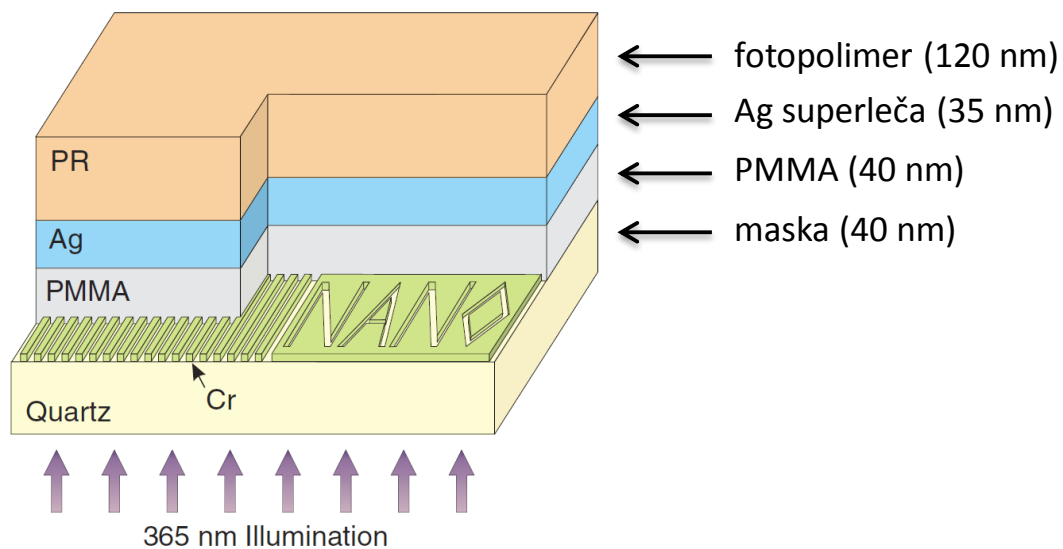

← fokusirani ionski snop (40 nm širina črte)

vir: Fang, Science 308, 2005

# Metamateriali – superleča

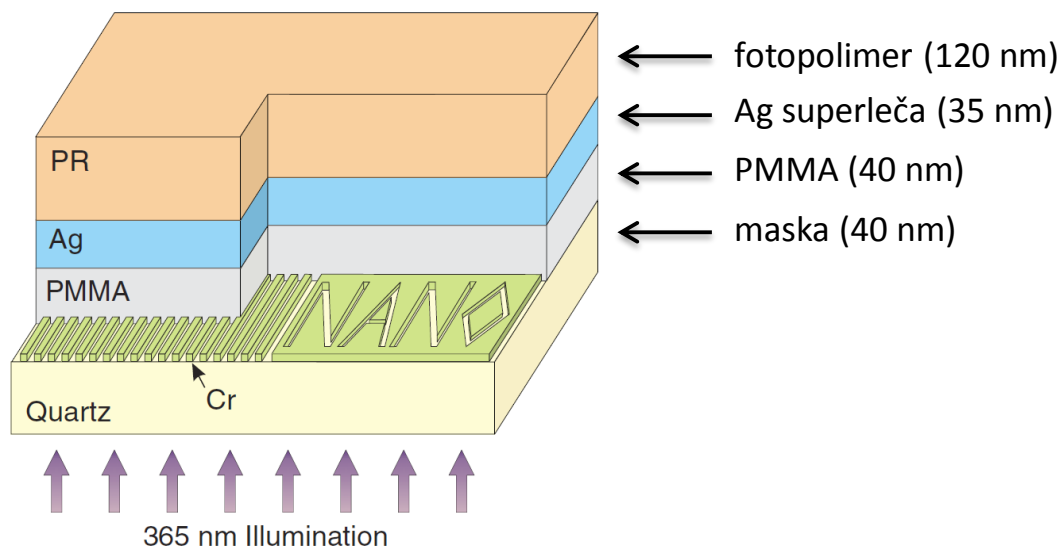

← fokusirani ionski  
snop (40 nm širina črte)



← AFM slike na polimeru  
z Ag superlečo

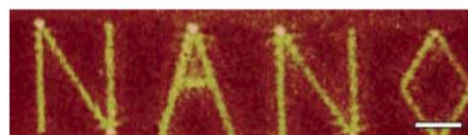

← AFM slike na polimeru  
brez Ag superleče

vir: Fang, Science 308, 2005

# Metamateriali – superleča

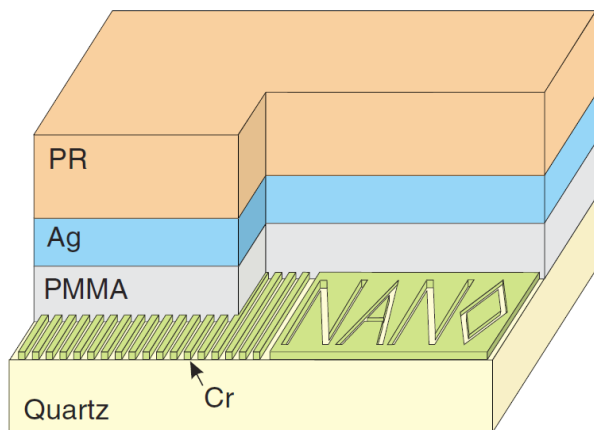

- ← fotopolimer (120 nm)
- ← Ag superleča (35 nm)
- ← PMMA (40 nm)
- ← maska (40 nm)

365 nm Illumination



← fokusirani ionski snop (40 nm širina črte)



← AFM slike na polimeru z Ag superlečo

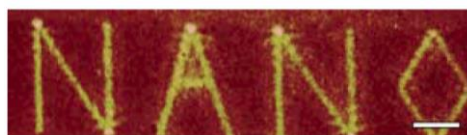

← AFM slike na polimeru brez Ag superleče

### Ločljivost

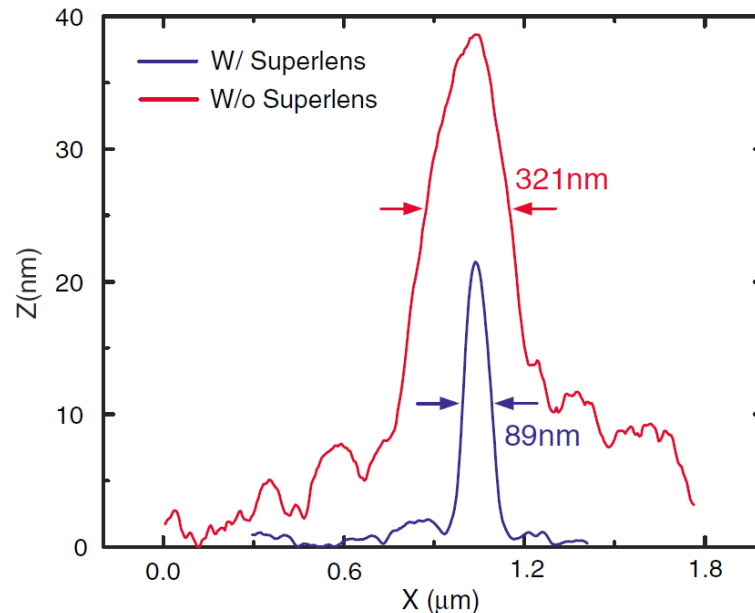

vir: Fang, Science 308, 2005

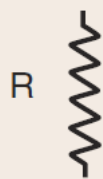
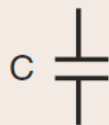

$$Z = -j/\omega A\epsilon$$

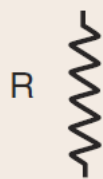
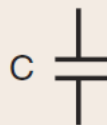

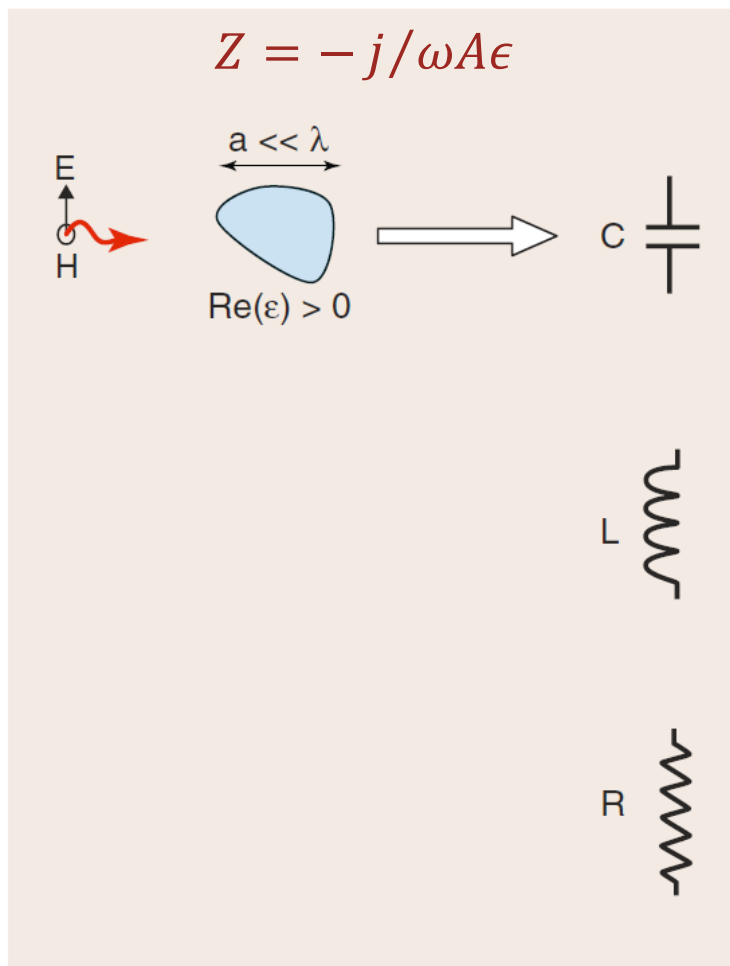



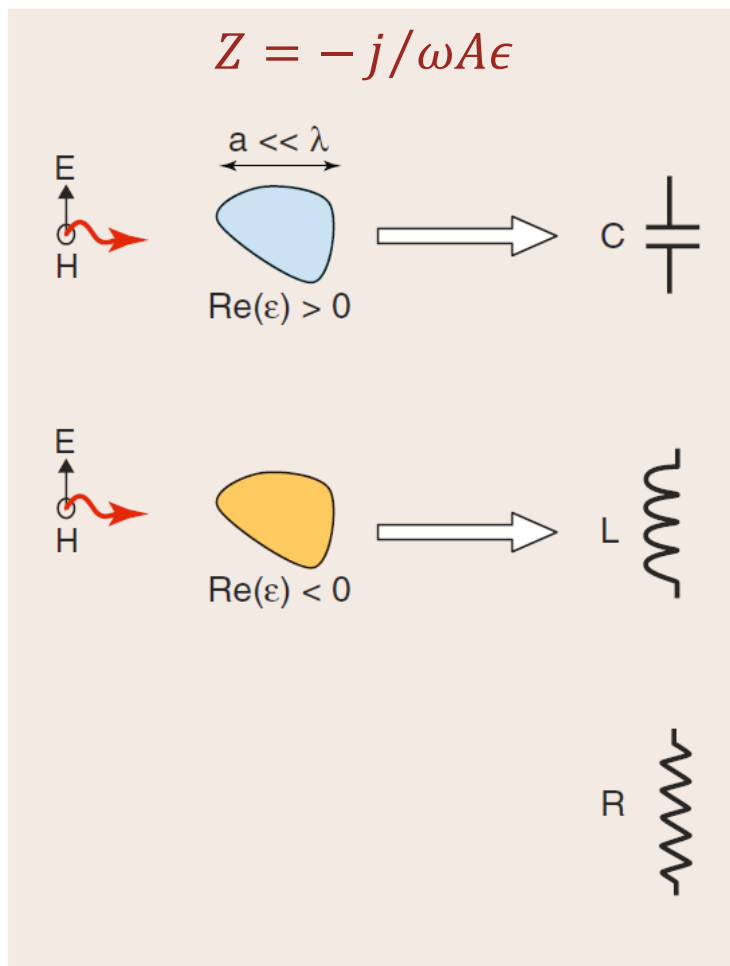

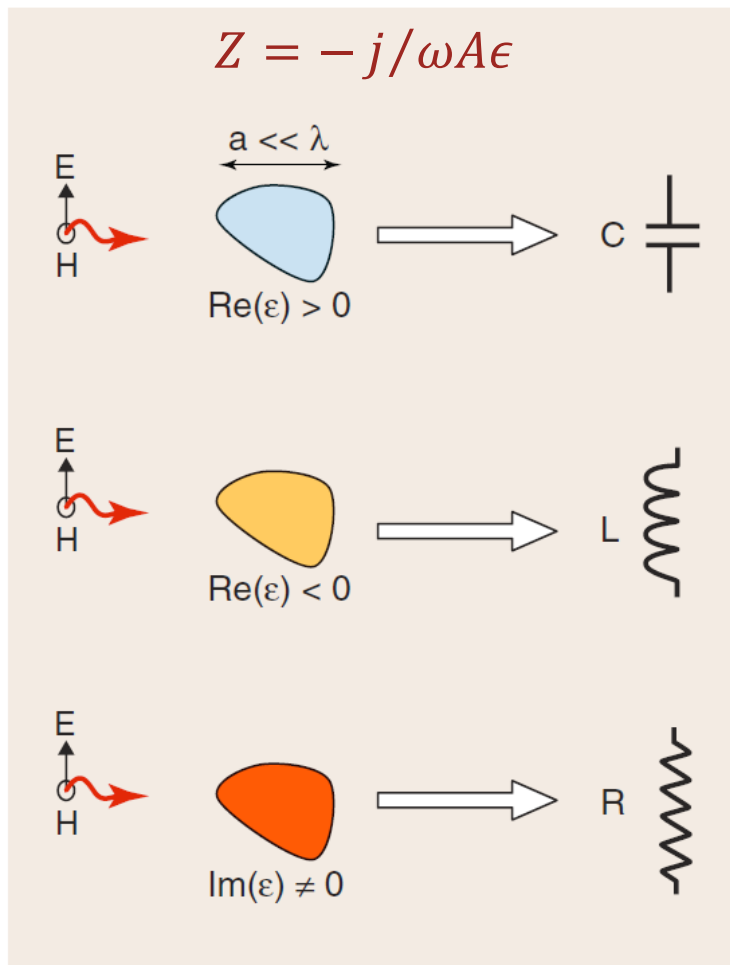

$$Z = -j/\omega A\epsilon$$

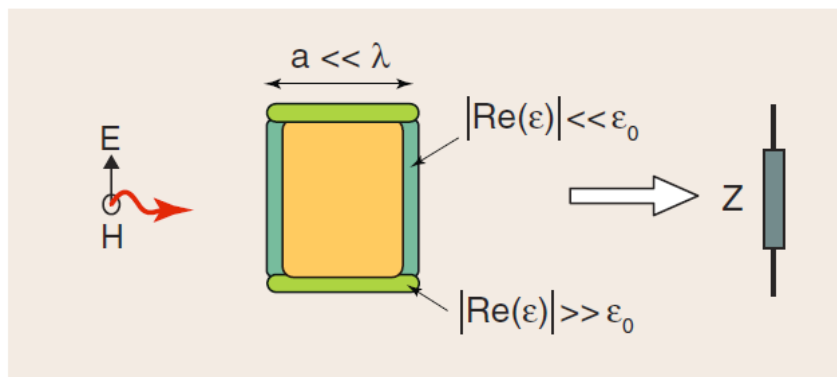
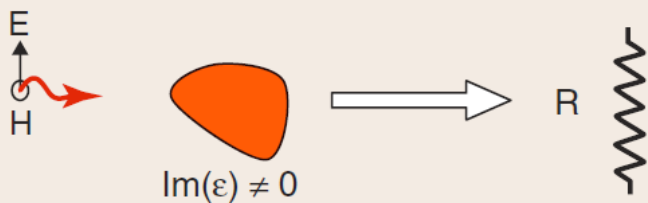
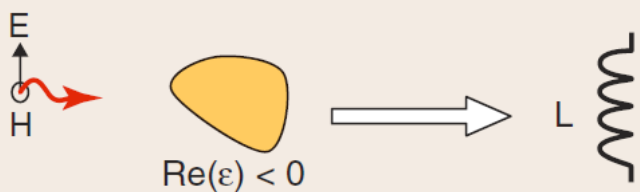
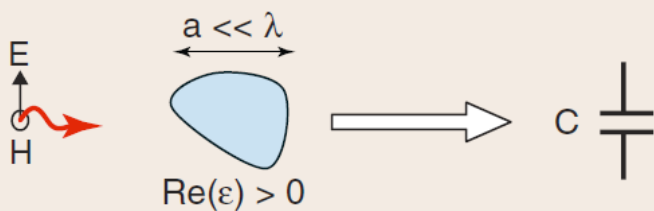

$$Z = -j/\omega A\epsilon$$

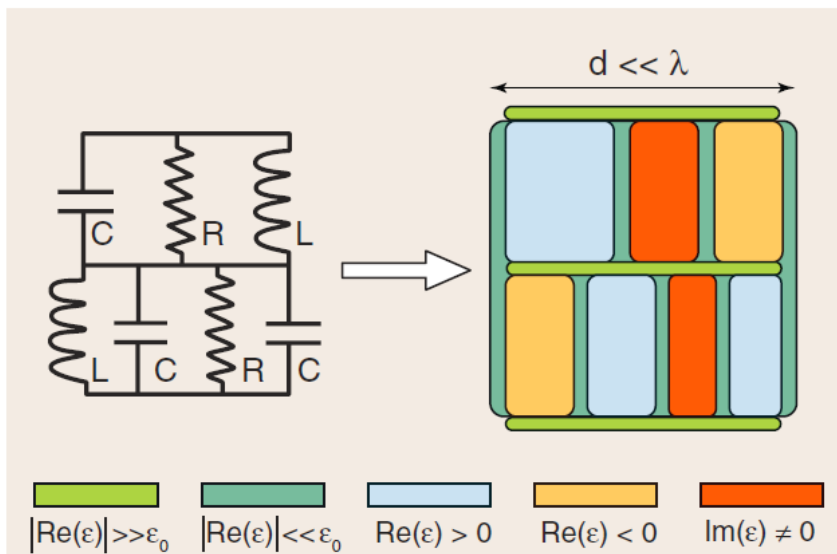
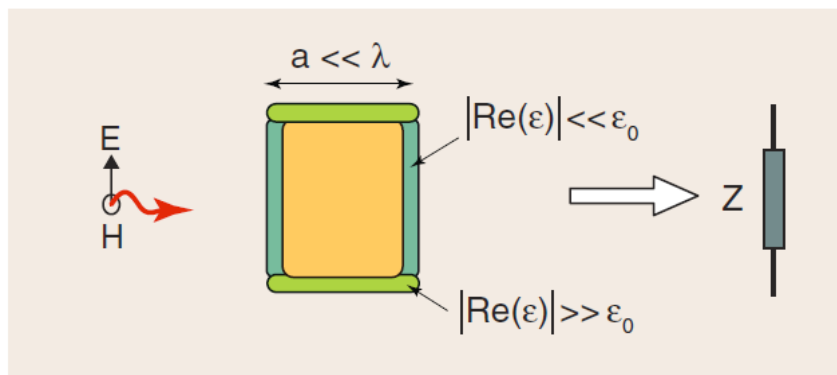
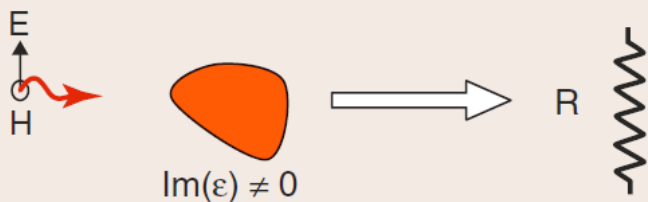
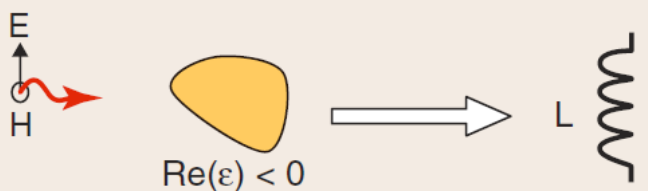
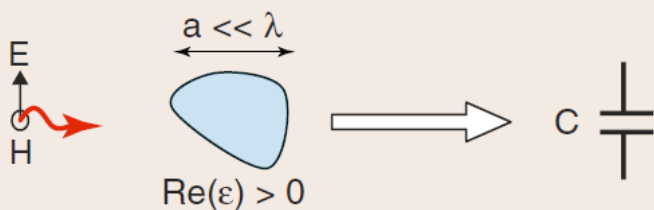

vir: Engheta, Science 317, 2007

# „Metatronika“

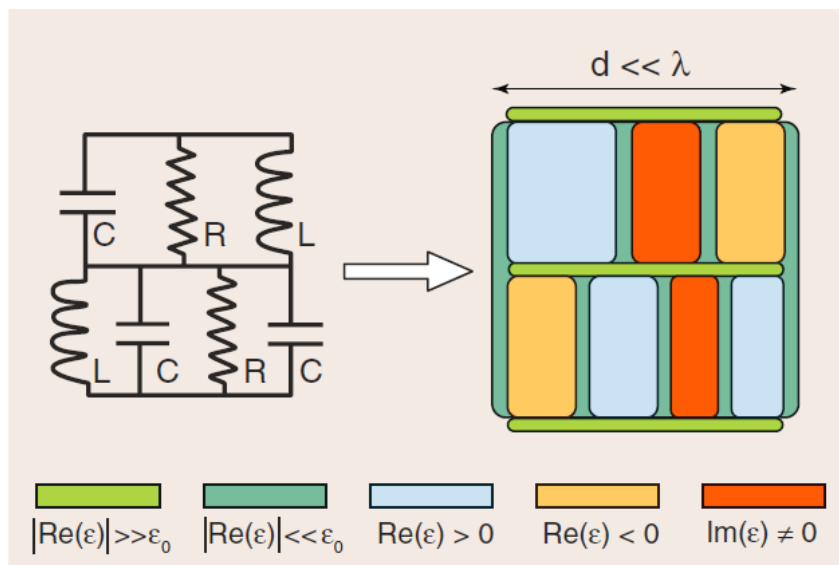
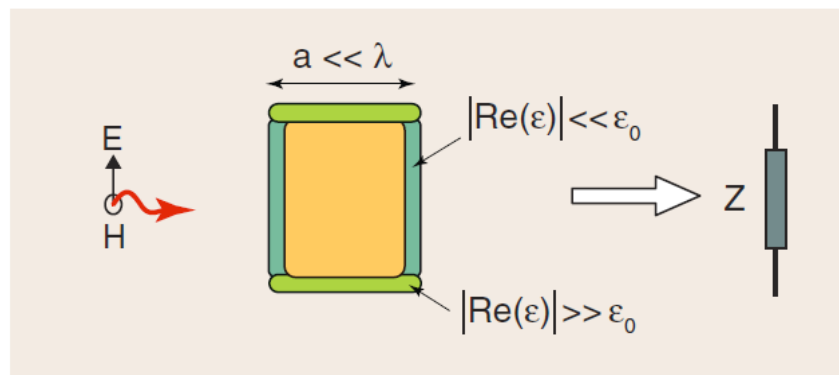
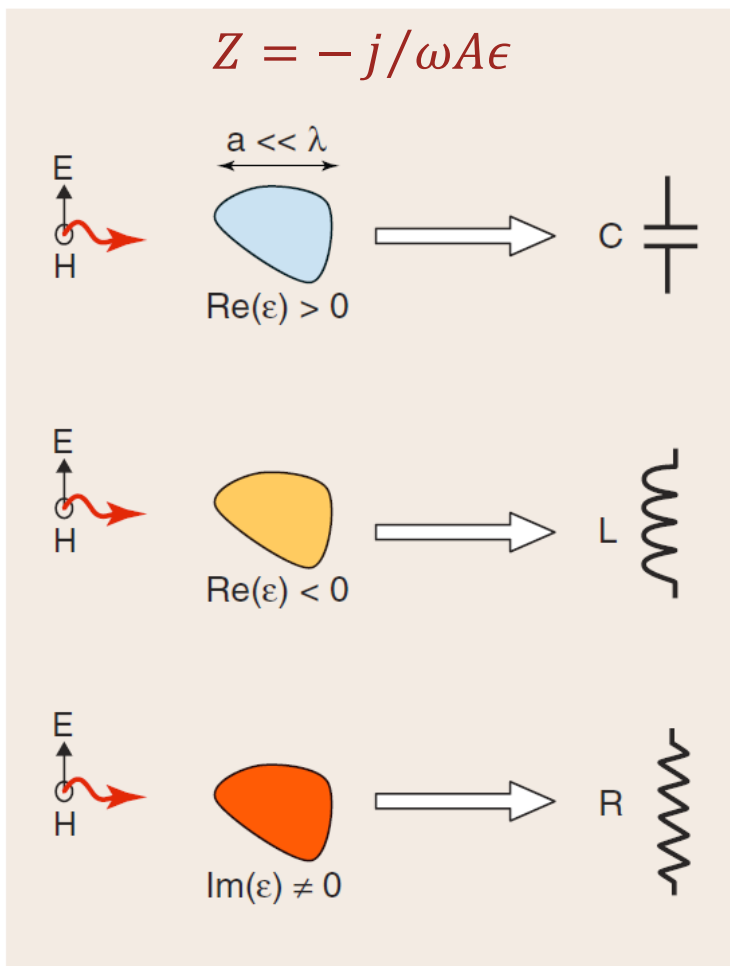

vir: Engheta, Science 317, 2007

## „Metatronika“

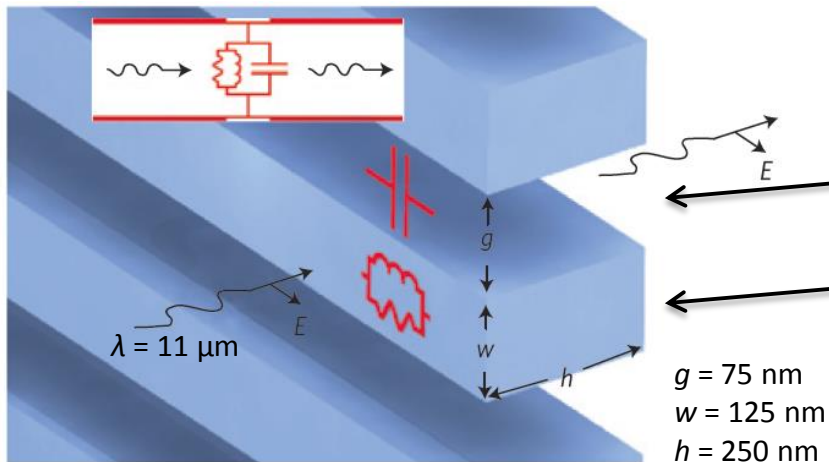

zrak [ $\text{Re}(\epsilon) > 0$ ,  $\text{Im}(\epsilon) = 0$ ]

$\text{Si}_3\text{N}_4$  [ $\text{Re}(\epsilon) < 0$ ,  $\text{Im}(\epsilon) \neq 0$ ]

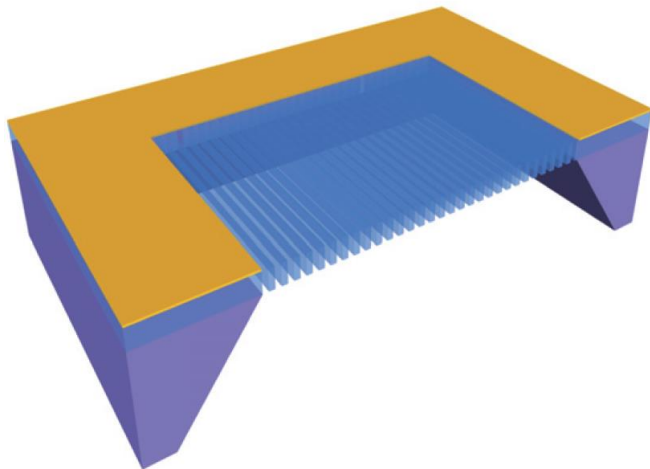

vir: Sun, Nature Materials 11, 2012

# „Metatronika“

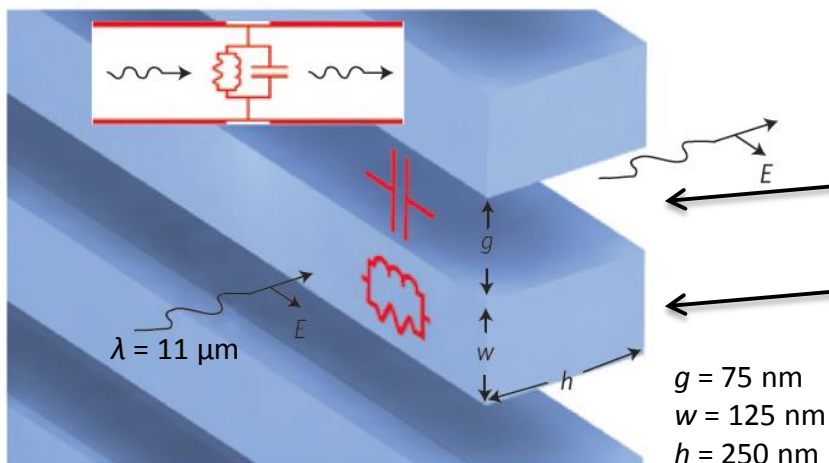

zrak [ $\text{Re}(\epsilon) > 0, \text{Im}(\epsilon) = 0$ ]

$\text{Si}_3\text{N}_4$  [ $\text{Re}(\epsilon) < 0, \text{Im}(\epsilon) \neq 0$ ]

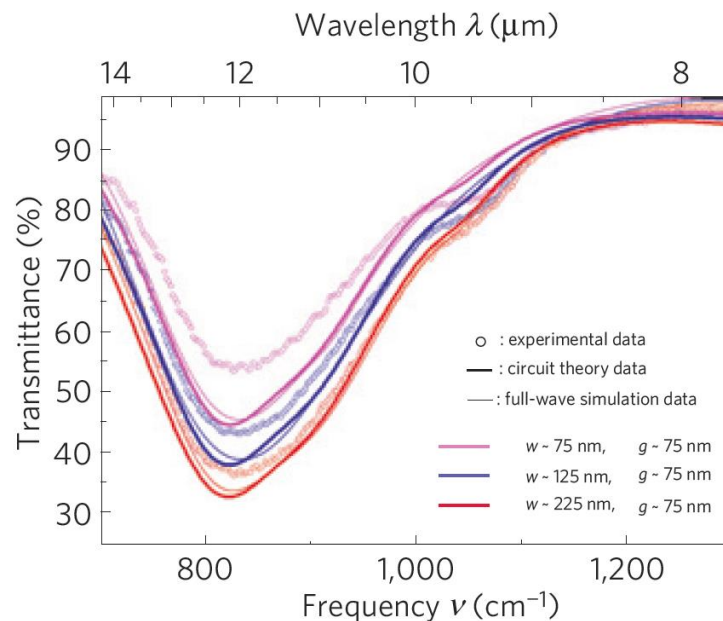

vir: Sun, Nature Materials 11, 2012

# „Metatronika“

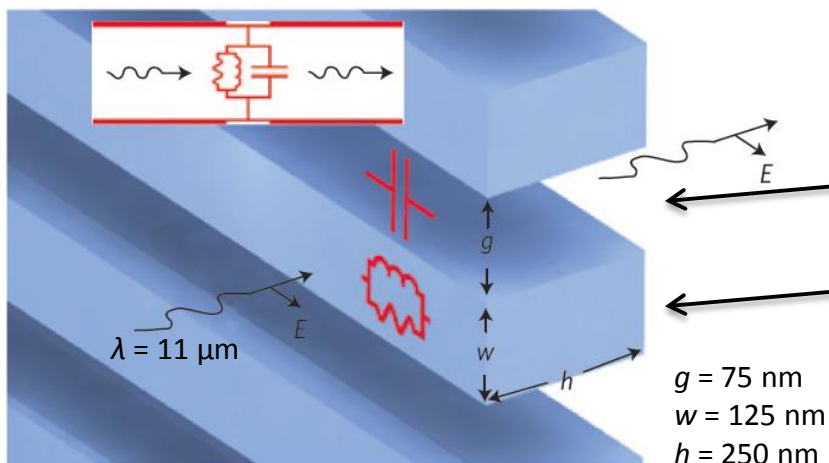

zrak [ $\text{Re}(\epsilon) > 0, \text{Im}(\epsilon) = 0$ ]

$\text{Si}_3\text{N}_4$  [ $\text{Re}(\epsilon) < 0, \text{Im}(\epsilon) \neq 0$ ]

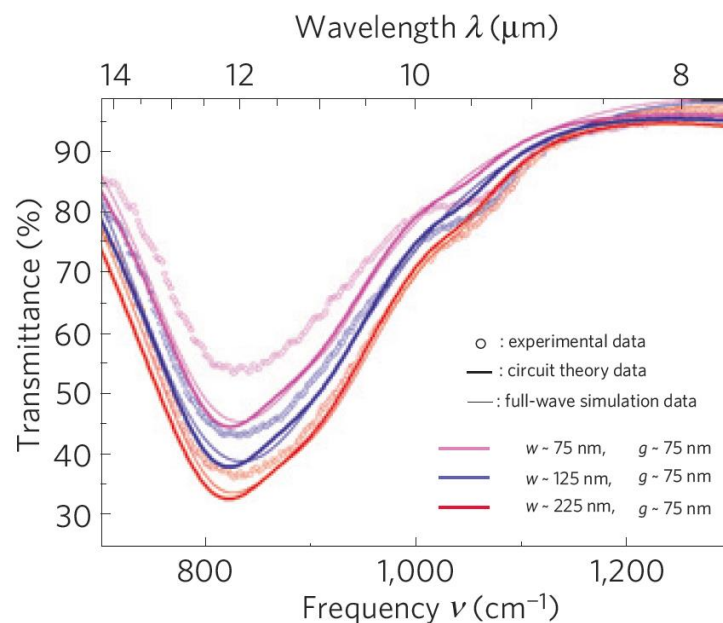
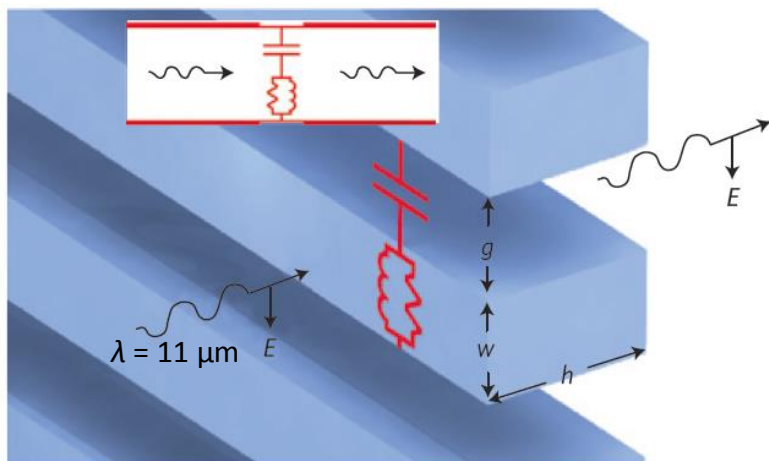

vir: Sun, Nature Materials 11, 2012



# 20. Nanotehnoški dan

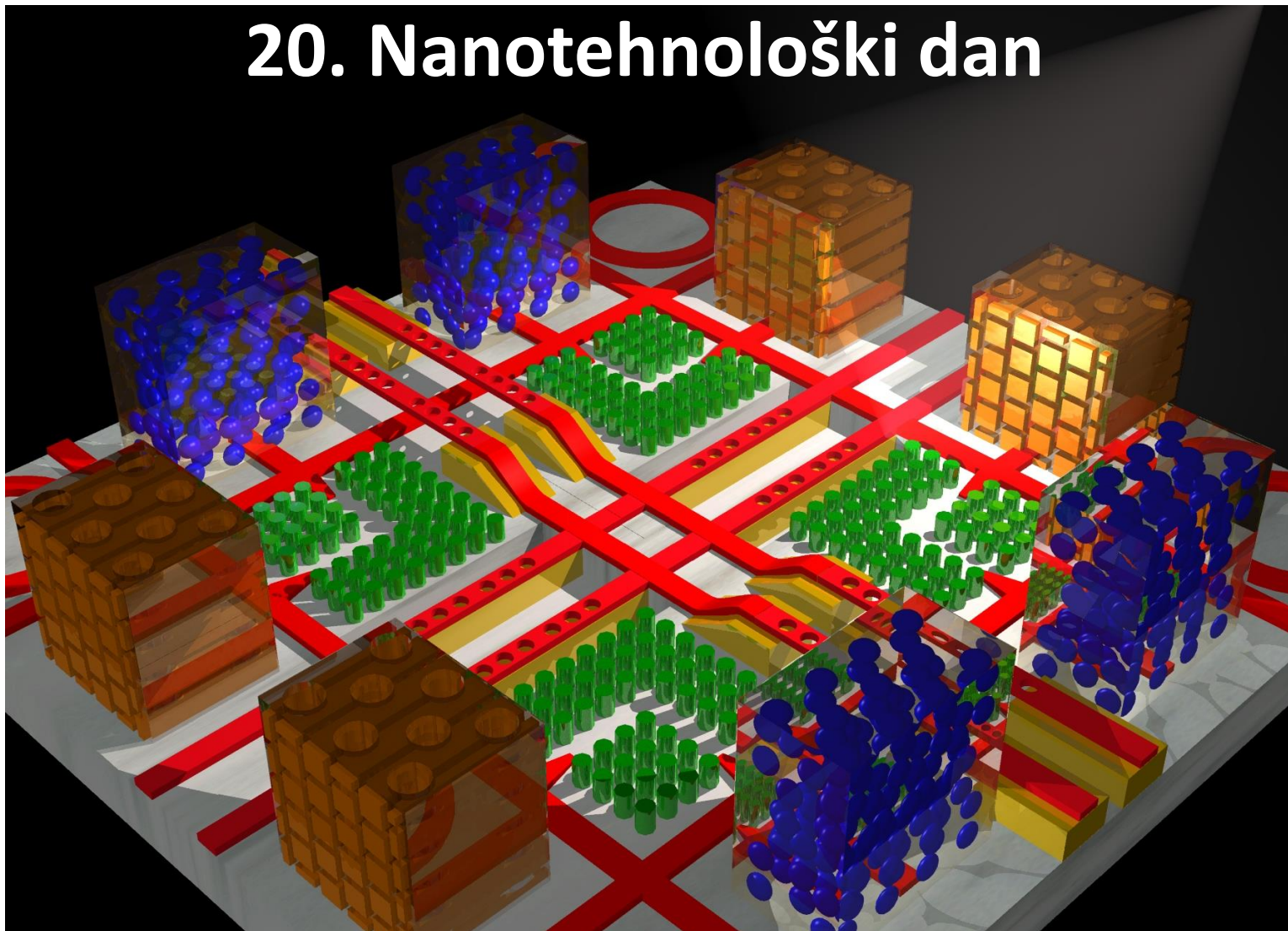

vir: MIT

Hvala za pozornost!