

INSTITUTIONAL ACT

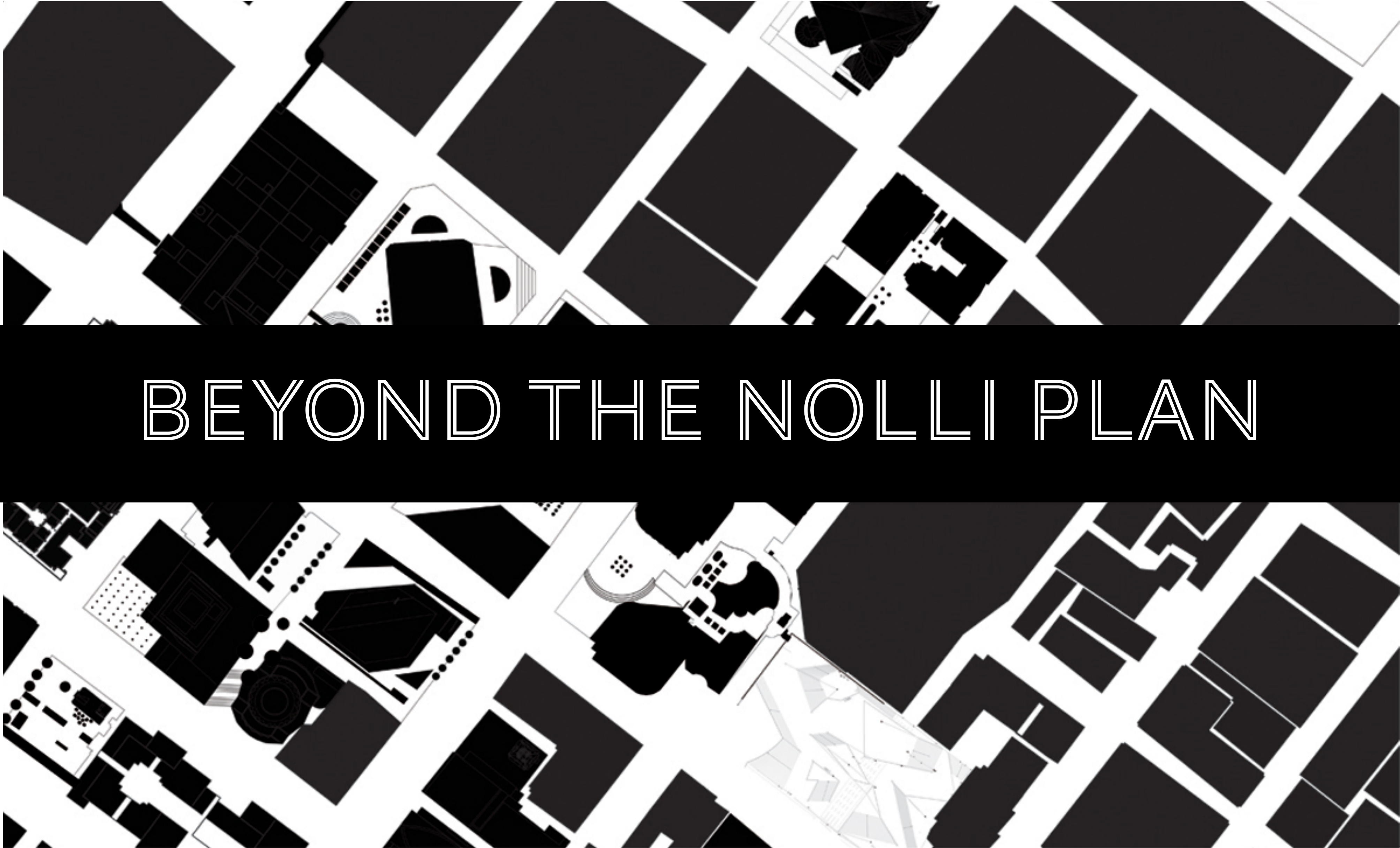

BEYOND THE NOLLI PLAN

HISTORY



FROM VOLUME MAKING

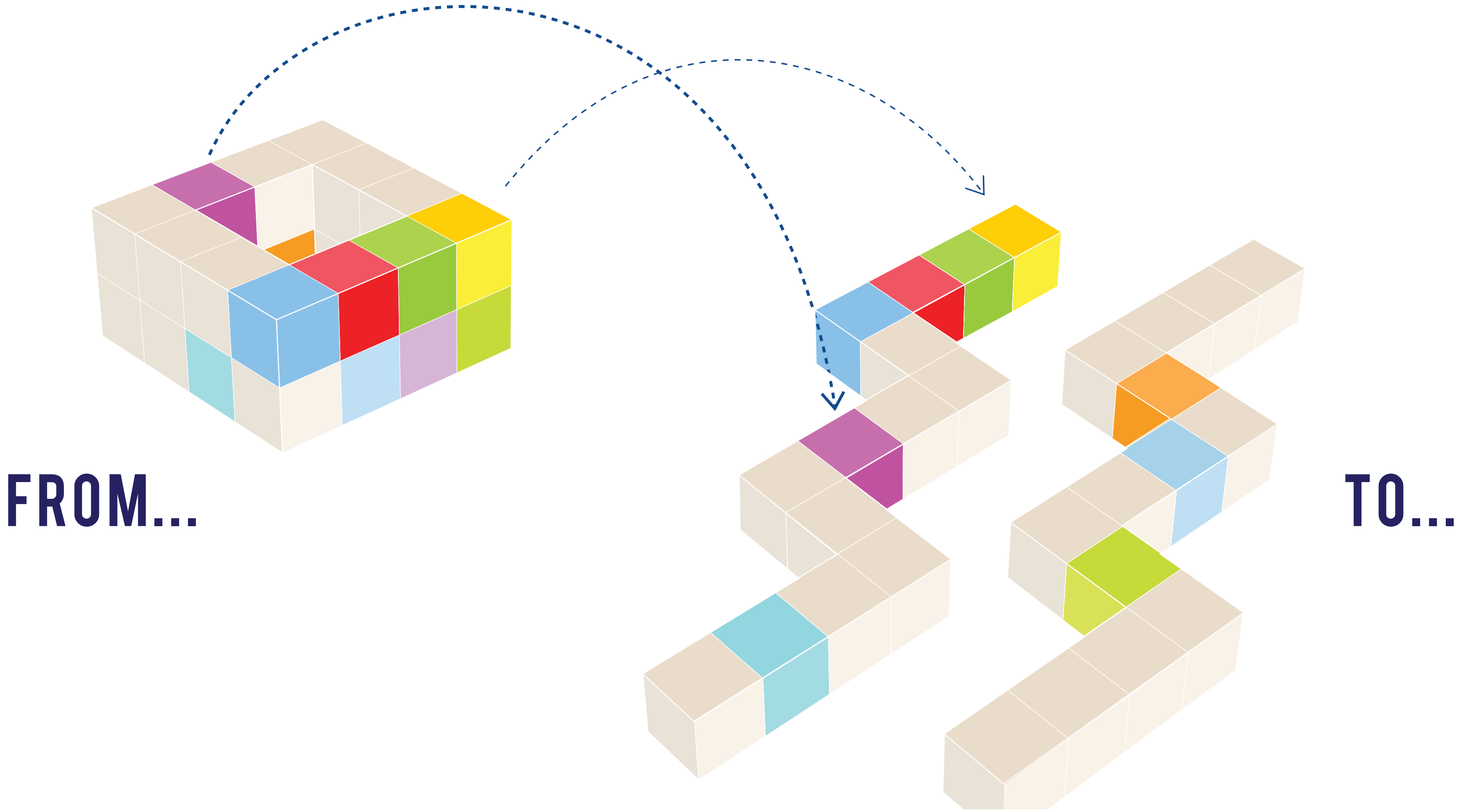

FROM REAL ESTATE TO REAL VALUE

VALUE



**MISSING FROM
THE STORY**

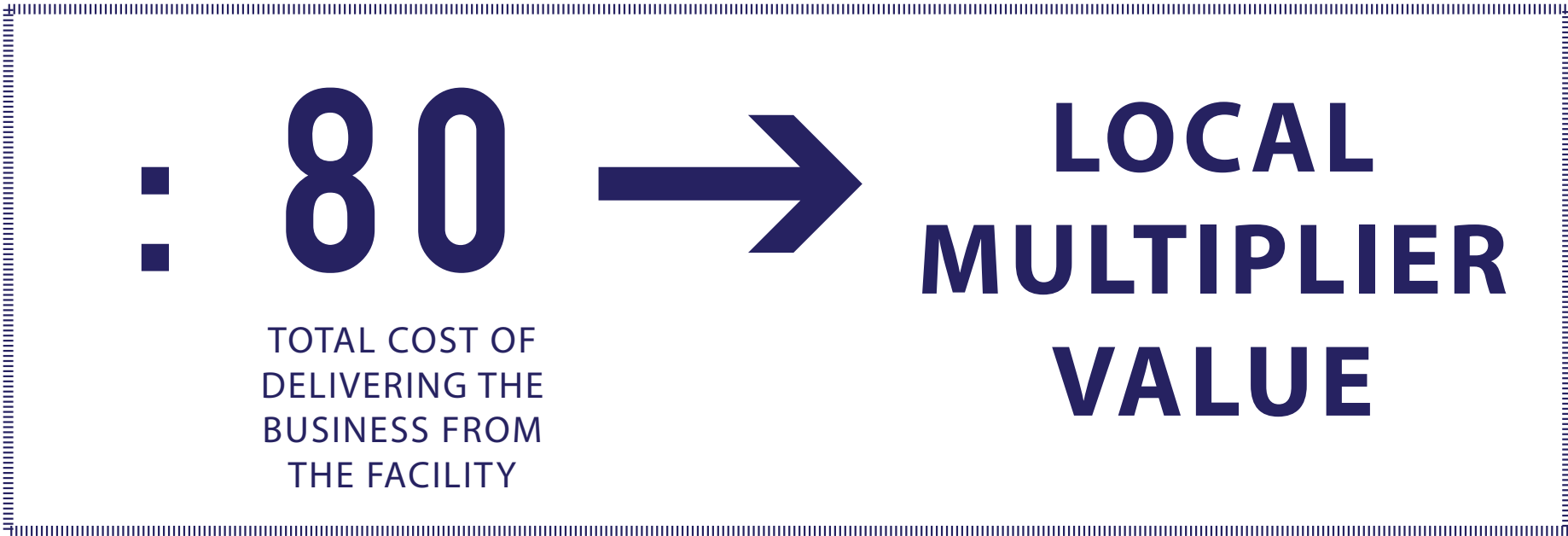

THE SOCIAL STATE

AGENCY CENTRALISED
AMONG OFFICIALS

RESOURCES DISPENSED BY
THE STATE

LABOUR FORCE MARKETS

PROPERTY OWNED BY STATE

GOVERNMENT-CONTROLLED
INFORMATION

THE PRIVATE ECONOMY

AGENCY CENTRALISED
AMONG EXECUTIVES

RESOURCES DISPENSED BY
THE CORPORATES

CAPITAL MARKETS

PROPERTY OWNED BY
CORPORATES

CORPORATE-CONTROLLED
INFORMATION

THE SOCIAL ECONOMY

AGENCY DECENTRALISED
AMONG CITIZENS

RESOURCES DISPENSED BY
CITIZENS

MASS CIVIC
ENTREPRENEURSHIP

PROPERTY PROTECTED BY
CREATIVE COMMONS

OPEN INFORMATION

// KEY BEHAVIOURS

THE CITY AS INSTITUTIONAL
ACT

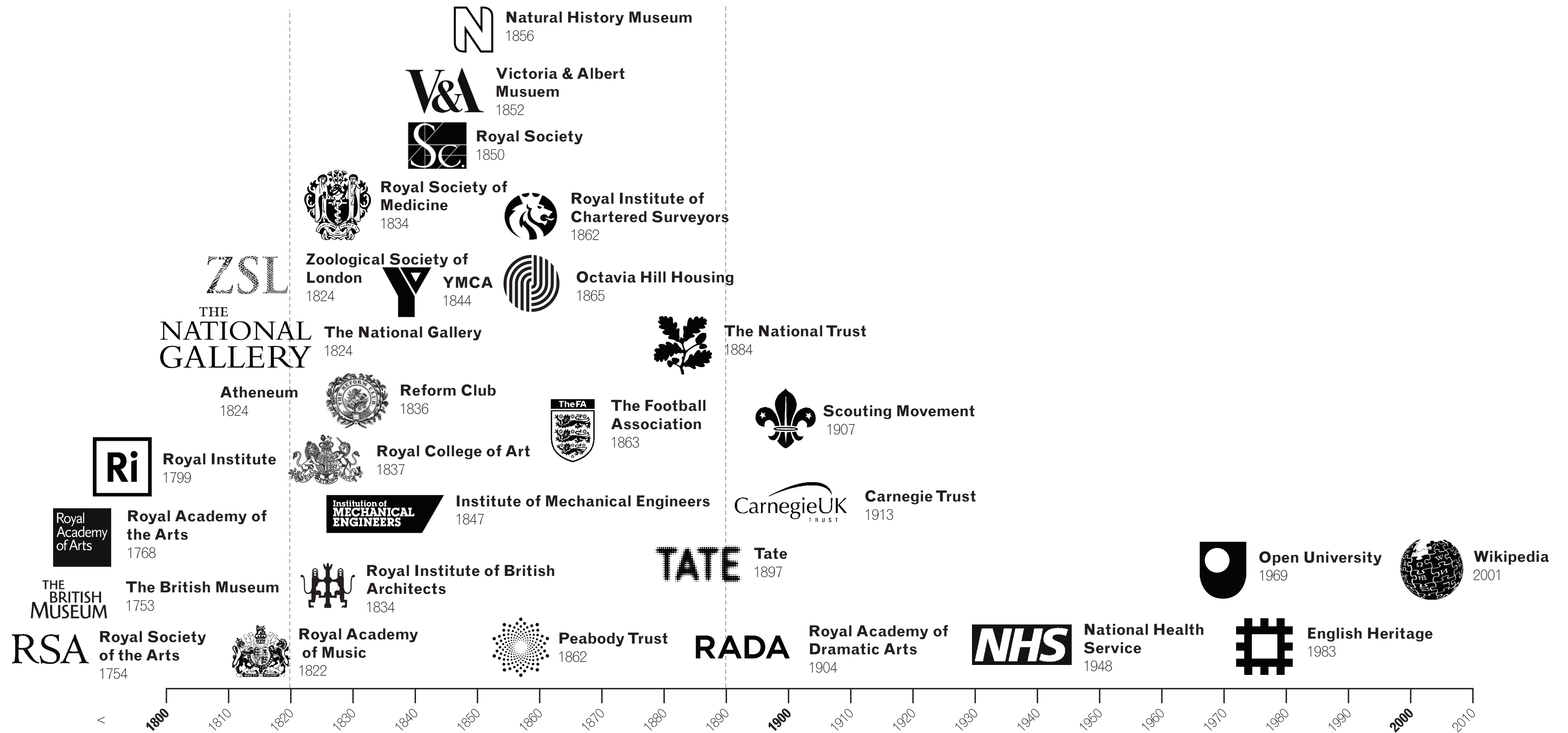

THE NEW INSTITUTIONAL AGE

WE ARE IN THE MIDST OF
THE DIS-INTERMEDIATION
THE INDUSTRIAL
INSTITUTIONAL FORM..

CAPITAL
DIS-INTERMEDIATED
BY P2P STRUCTURES,
CROWD-FUNDING ETC

SOCIAL MEDIA IS
DISINTERMEDIATING THE
ACCESS TO TALENT &
KNOWHOW- P2P [TWITTER,
LINKEDIN]

SELF ORGANISATION &
COLLABORATIVE
MANAGEMENT BUILT ON
USER CENTRIC - OPEN
SCALE FREE PLATFORMS...

CAPITAL GOODS - OPENED
UP FOR FRACTIONAL
ACCESS & MANAGEMENT -
SPACE & TIME

LEADERSHIP SHIFTING TO
NETWORK & MOVEMENT
HOSTING & TRUST
BRIDGING/UNDERWRITING..

ALL BUILT ON PLATFORMS...
PHYSICAL, BRAND, DIGITAL
PLATFORMS... =
FOR ACTOR DRIVEN
ACTIVITY

RE BIRTH OF HUMAN
CENTRIC ECONOMIES

FROM A COLLABORATIVE
CORPORATIVE TO
COOPERATIVE PLATFORMS
UPON ECOSYSTEMS
VENTURES OPERATE.

THE BIGGEST
REORGANISATION OF THE
INSTITUTIONAL FORM

ITS REAL...

BROOKLYN SUPERHERO SUPPLY CO.

— ALL —
MERCHANDISE
100% CERTIFIED
& AUTHENTIC

★ ★ ★ SERVING BROOKLYN AND THE GREATER METROPOLITAN AREA ★

EXCLUSIVE SOURCE FOR
AARDVARK BROS. PRODUCTS

• COSTUMES **DASTARDLY PLOTS WILL BE FOILED** SPECIAL PROGRAMS

• EYEWEAR *'Ever vigilant, ever true.'* **FOR TELEPATHS** *Inquire within*

• INVISIBILITY **FULL CAPERY** *AFFILIATED*

• INSTRUCTIONAL MANUALS **UNDERGROUND LAIRS WILL BE FOUND**

SUPERPOWERS: DOMESTIC AND INDUSTRIAL-GRADE SERVICES

★ ★ ★ ★

— S.I.K.s OF ALL TYPES —
GUARANTEED UNTRACEABLE —

WE CAN HELP YOU WITH
YOUR NEMESIS PROBLEM

TELEPHONE: (718) 499-9884

372 FIFTH AVE.

SIGNALING CARDS
AVAILABLE:
Atlantis and Most Other
Last Continents —
FREE after 11PM

SECRET ALLIANCES WILL BE FORGED

SUPERSONIC SHIPPING TO SELECT UNIVERSES

826 NYC
ALSO INSIDE



SPECIALIZING IN HIGH-QUALITY SUPERHERO EQUIPMENT

THERE IS NO NEED TO SHOP ANYWHERE ELSE

Ask inside!
WE CAN
CUSTOM-ORDER
— ALTER —
EGOS

SIDEKICK PLACEMENT SERVICES FAST & RELIABLE

MANY ITEMS ARE SPLENDID

FRILLY LICENSED & BORGED

EVER VIGILANT, EVER TRUE.

IF WE DON'T HAVE IT, A SUPERHERO DOESN'T NEED IT.

826 NYC HQ OFFICES OF 826NYC
372 FIFTH AVENUE
718-499-9884 • www.826nyc.org

DO NOT BE ALARMED — ALL IS SECURE

OUR PRODUCTS ARE THESE:

- | | | | | | |
|---|--|---|---|--|--|
| <p>100% AUTHENTIC HIGH-QUALITY COSTUMES</p> <ul style="list-style-type: none"> Waders.....for outdoor activities Club Uniforms.....for playing in Combinations.....dual and planning Goggles & Visors.....for those who need Super Breath-Gel.....for long lasting durability | <p>WE HAVE SELECTION OF SUPERHERO GEAR</p> <ul style="list-style-type: none"> Protonic Masks & Helmets.....for fighting S.I.K.s.....for daily defense Star Club & Sponges.....for maximum ball | <p>PRODUCTS BY WEB SYSTEMS</p> <ul style="list-style-type: none"> Building Kits.....for construction Tools & Materials.....for repairing | <p>Shipping Methods.....for your needs</p> <ul style="list-style-type: none"> Overnight / Standard Ship.....for shipping Next Week Order With No Tracking Number.....for shipping Trackers.....for tracking Money Back Guarantee.....for returning | <p>Worlds of 826 Toys & More</p> <ul style="list-style-type: none"> Collectible Figurines.....for collecting Movie Figures.....for personal display Figures.....for trading, display, collecting | <p>Specialty Accessories.....for your use</p> <ul style="list-style-type: none"> Character Figurines.....for collecting Full Construction Kits.....for use in the process Resizing Remedy.....for adjusting Character Composites.....with character Health Insurance.....for saving Maps & Plans.....for fully accurate Specialty Tools.....for your needs |
|---|--|---|---|--|--|

Please do not use your X-ray vision inside the store

ALL TRANSLUCENT EQUIPMENT GUARANTEED UNDER LIGHTS ONLY — NO EXCEPTIONS!

ONE STOP FOR ALL YOUR FOE-BATTLING NEEDS

WIDECOST MAPS
LATEST EDITIONS
No supplements needed
No artwork cost!

EMERGING INTO ACTION IS OUR SPECIALTY

CONTROL THE POWER OF YOUR MIND
BRIDGLEY'S #1 SOURCE FOR TELEKINESIS

LICENSED INVISIBILITY TESTING CENTER

SAFE & DISCREET
YOUR SECRET IS SAFE WITH US

EXPOSED TO RADIATION EXPERIMENTS?
Check our Radiation Charts for What to Expect

WE HAVE OXYGEN GUM

MT. FORTRESS CLOTHING SOLD HERE

SEARCH OR UNSUBSCRIBED
BEST RATE
NOT AVAILABLE AT THIS TIME

PLEASE COME IN For a Complimentary Cost & Mask Assessment

FREE LEGAL ADVICE FOR WISDOM DRINK PROTECTORS (Must be wearing your mask)

PLEASE ACCESS THE NEGATIVE ZONE OUTSIDE THE STORE

WE CARRY DESYNCHRONOUS SYSTEMS
Satellite and Laser not included

www.superherosupplies.com

We've launched an exciting new project of our own! Introducing the Kickstarter app for iPhone!

KICKSTARTER

What is
Kickstarter?

Discover
great projects

Start
your project

Help [Sign up](#) [Log in](#)

Discover Projects

Passion, ideas, and ambition abound. Start exploring!

Staff Picks



Silo Art Project

by Rick Sinnett

A MEGA MURAL titled "This Land" to be painted on the giant silos of Rocktown in downtown Oklahoma City

Oklahoma City, OK

27% FUNDED **\$4,472** PLEDGED **23** DAYS TO GO



S.W. Basics Small Biz Film Project: A Make-umentary

by S.W. Basics

Grab some cheezitos and purpleberry slurshies because we're taking a documentary road trip, and we want you riding shotgun.

Brooklyn, NY

8% FUNDED **\$1,742** PLEDGED **27** DAYS TO GO



The Fantastic Toes Debut Album!

by Tony Rasmussen

A smokey serenade from the city of angels. Spooky swing for the discerning ear...

Los Angeles, CA

16% FUNDED **\$991** PLEDGED **28** DAYS TO GO

Video mode

★ Featured

Staff Picks
Popular
Recently Launched
Ending Soon
Small Projects
Most Funded
Curated Pages

📁 Categories

Art
Comics
Dance
Design
Fashion
Film & Video
Food
Games
Music
Photography
Publishing
Technology
Theater

[→ See more staff picks](#)

Popular This Week









RUTLAND TELECOM



01
 SHARED AWARENESS OF DISSATISFACTION THROUGH INFORMAL DISCUSSIONS OVER TIME



02
 FUTURE ENTREPRENEUR HAS AWARENESS OF TECHNOLOGICAL / REGULATORY POSSIBILITY



03
 ENTREPRENEUR ORGANISES MEETING IN VILLAGE HALL INVITING LOCAL PEOPLE AND PROVIDING CHAMPAGNE



04
 OVER 10 MONTH PERIOD, REPEATED PUBLIC MEETINGS & INFORMAL CONVERSATIONS; AT THE END: 40PRE-REGS OBTAINED AS WELL AS STARTING CAPITAL



05
 ROLE OF THIRD PARTY INFLUENCERS TO 'TRANSLATE' TECH-TALK INTO LANGUAGE THAT VILLAGERS UNDERSTAND AND TRUST



06
 SUPPORT FROM PARISH COUNCIL AND PLANNING PERMISSION OBTAINED



07
 MEANWHILE BATTLES WITH BT OVER TECHNICAL AND CONTRACTUAL FACILITATION -REGULATORY OBLIGATIONS



08
 LAST-MINUTE FUNDRAISING FOR ADDITIONAL CAPITAL NEEDS RAISED SHORTFALL OF £10K IN A SINGLE DAY

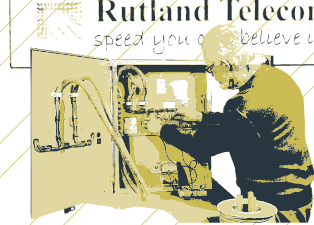

09
 TRIALS AND OPENING

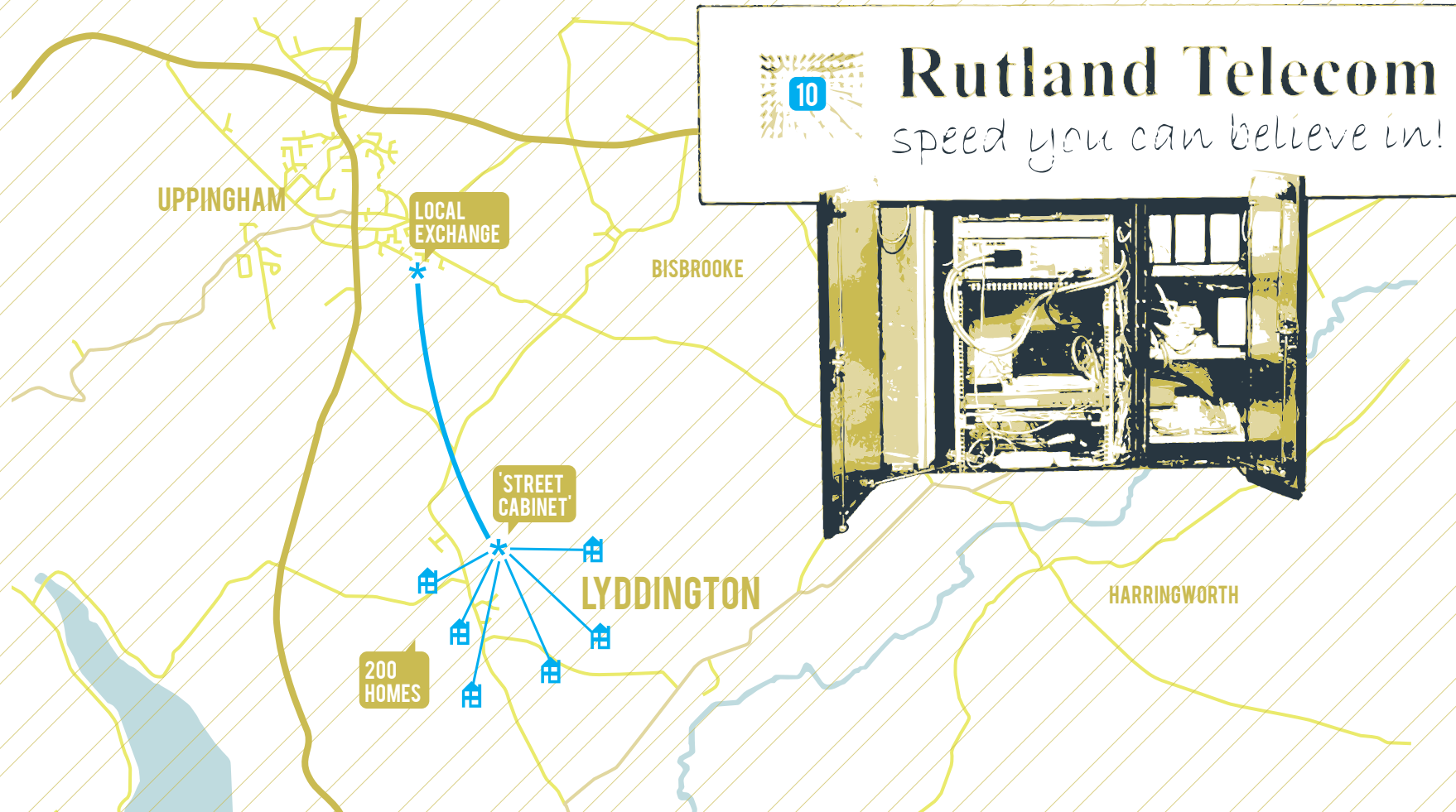

5 CONTINENTS

36 ACTIVE HUBS

7000

VALUES DRIVEN
ENTREPRENEURS
SEEDING AND
SCALING IDEAS

1500 NEW HUB
ENQUIRIES
PER YEAR





WikiHouse is an open source construction set. Its aim is allow anyone to design, download and 'print' CNC-milled plywood houses and components, which can be assembled with minimal formal skill or training.

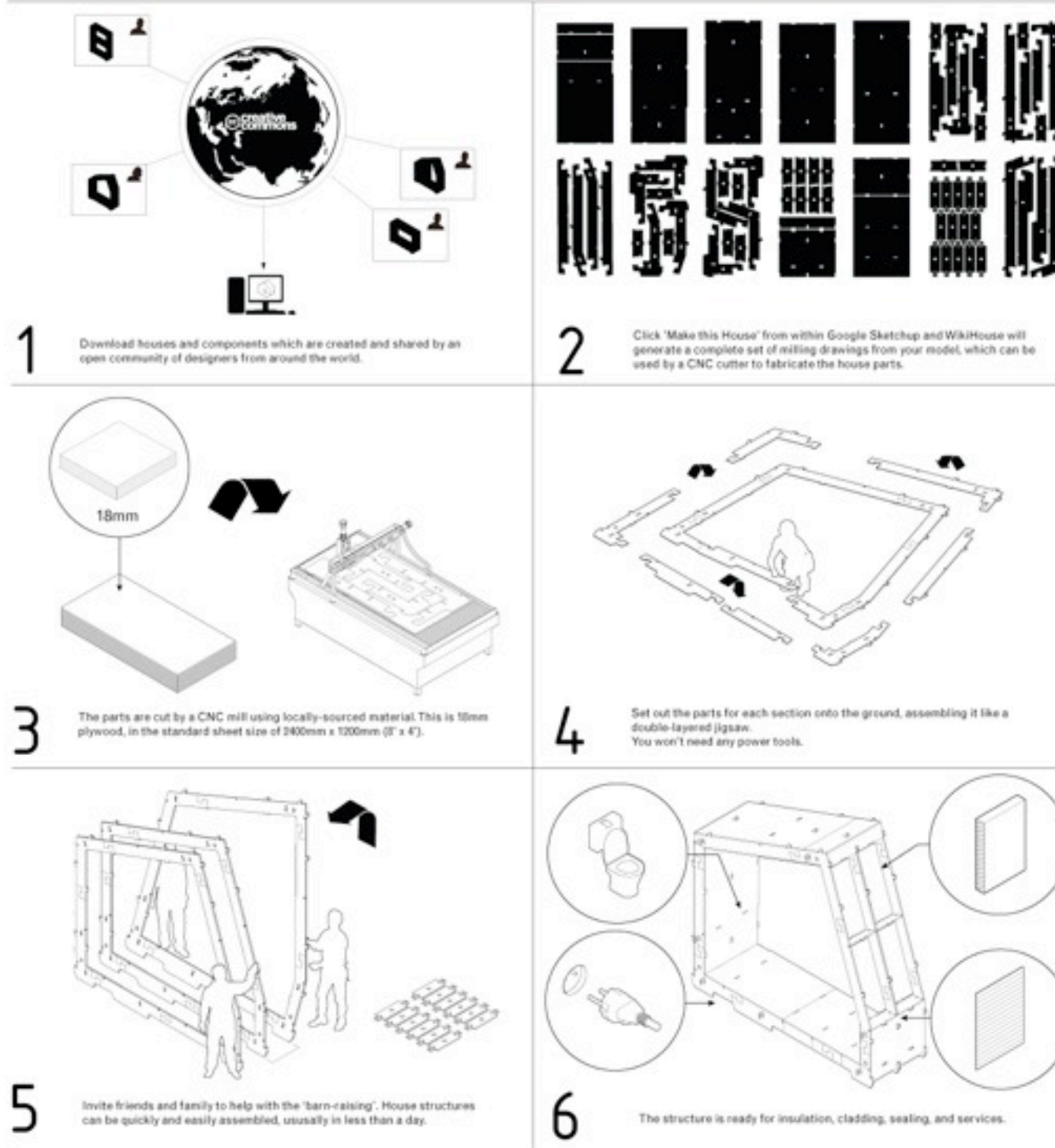

The first WikiHouse prototype at the Gwangju Design Biennale 2011



WikiHouse for the LDN Prototype Lab being assembled at Hub Westminster



Gwangju Design Biennale Start
2nd Sept '11

Gwangju Design Biennale End
23rd Oct '11

WikiHouse LDN Prototype Lab @ Hub Westminster
28th Oct '11

WikiHouse LDN Lab v.2 Seed House
Feb '12

Apr '12

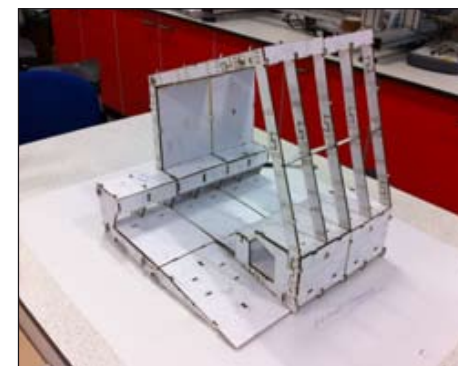

Scale model of the Chelmsford WikiHouse

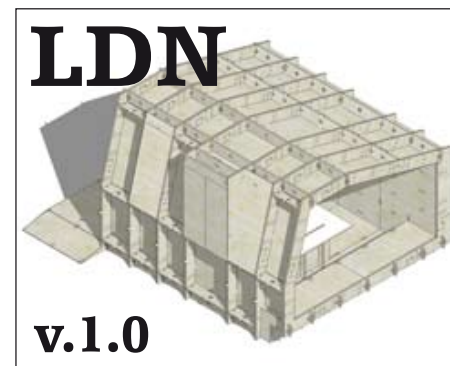

v.1.0

[DEVELOP LDN PROTOTYPE TO V.1.0 HABITABLE STRUCTURE - SEED INTERNATIONAL LABS]

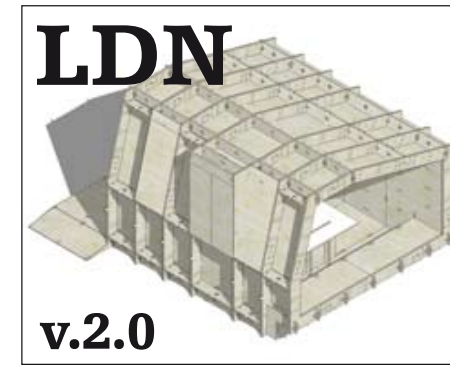

v.2.0

[DEVELOP LDN PROTOTYPE TO V.2.0 HABITABLE STRUCTURE - SEED INTERNATIONAL LABS]

WikiHouse aim to continue development through a number of focused Labs and prototyping sessions through 2012.

Two initial Labs are proposed, building on the new WikiHouse prototype at the Hub Westminster with a view to further developing the construction system and exploring solutions to the more diverse systemic problems of house (eg. energy, water, ventilation).

The LDN Labs will then seed further international labs with a view to forwarding collaborative development of a Complete Open Source Construction System across a number of locations throughout the world (interest from Spain, Germany, the US, and the UK to date, and possible first live implementations in Haiti and Japan). This development will be supported by WikiHouse through further technical software development and general architectural and design guidance.

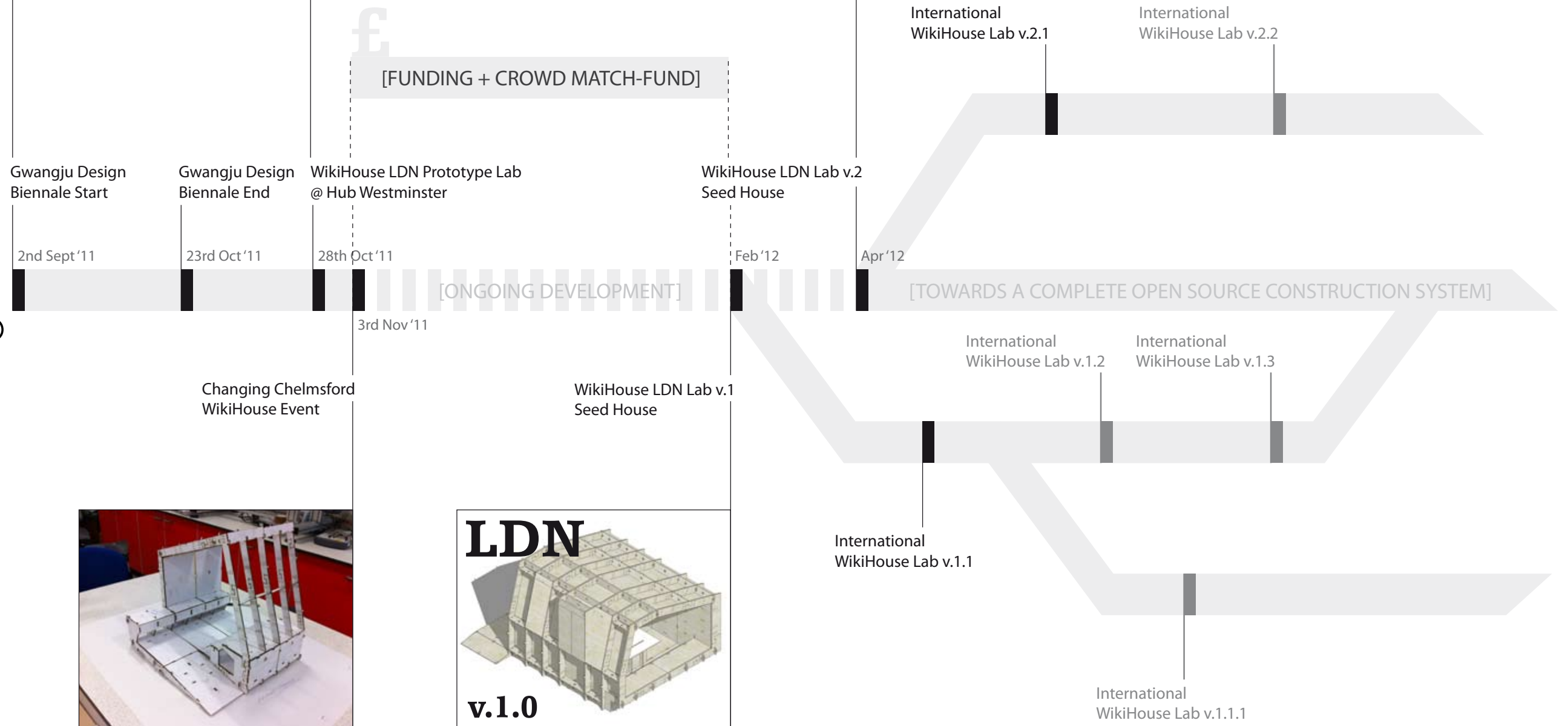

Prototype

In 2011 we tested the market with WikiHouse - an Open Source Construction Set

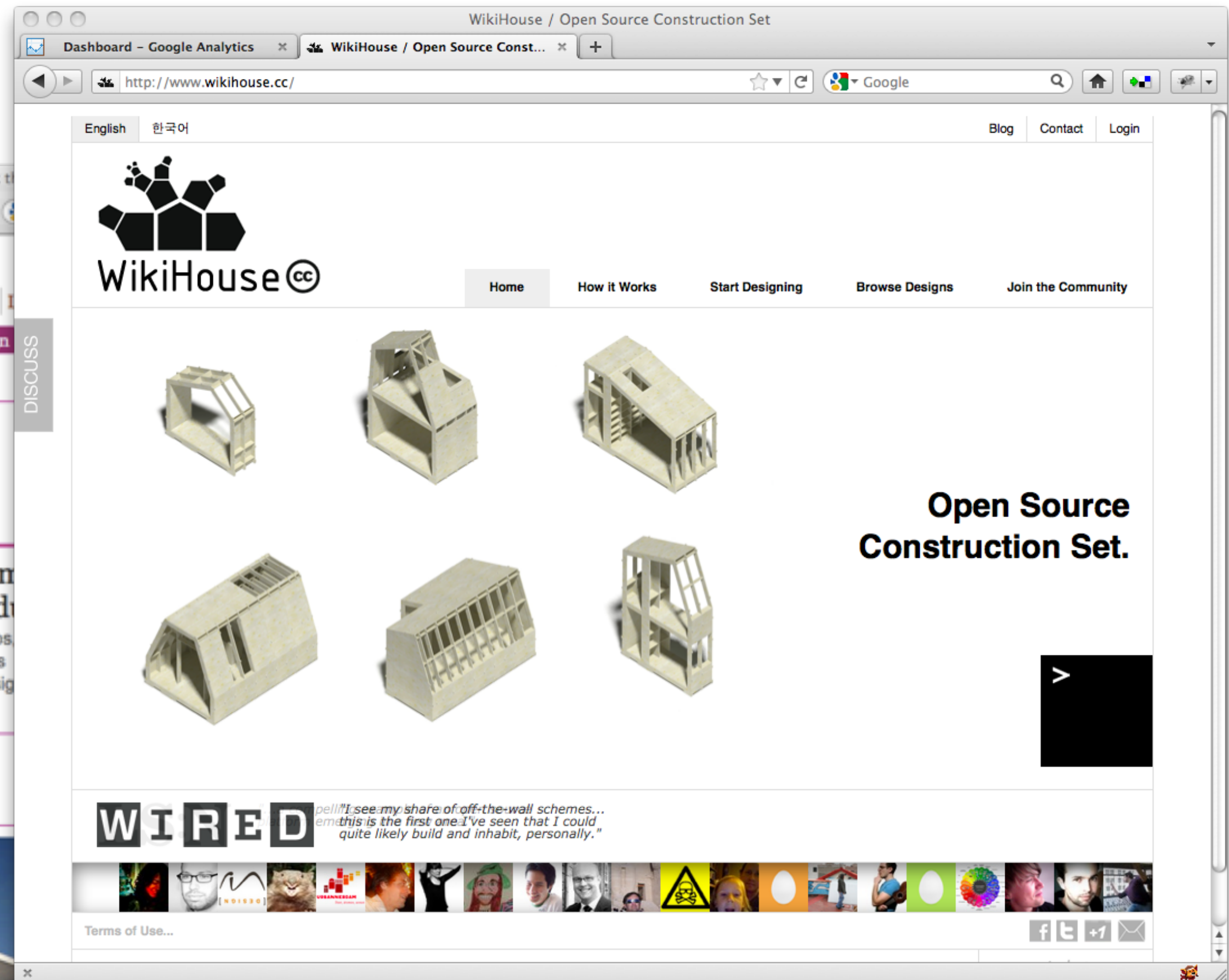

Print Your House

WikiHouse explored some key concepts borrowed from open source software and applied to open hardware...

- open construction standards
- open collaborative web platform
- community tools

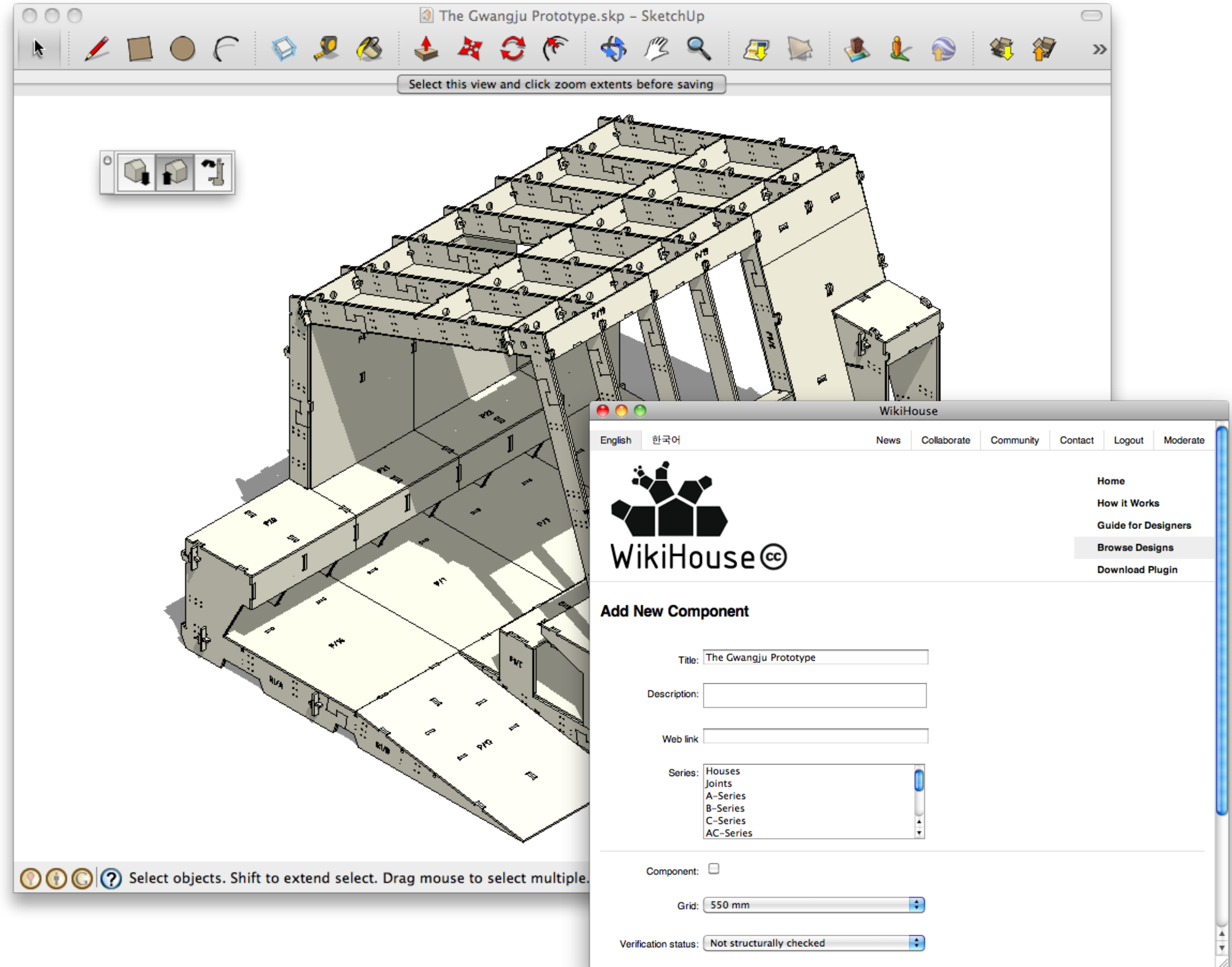

Viral Global Reach

WikiHouse generated a large amount of global coverage. Most interest focused on the idea of increased access to a typically complex and unaffordable product, designed and manufactured through open digital processes

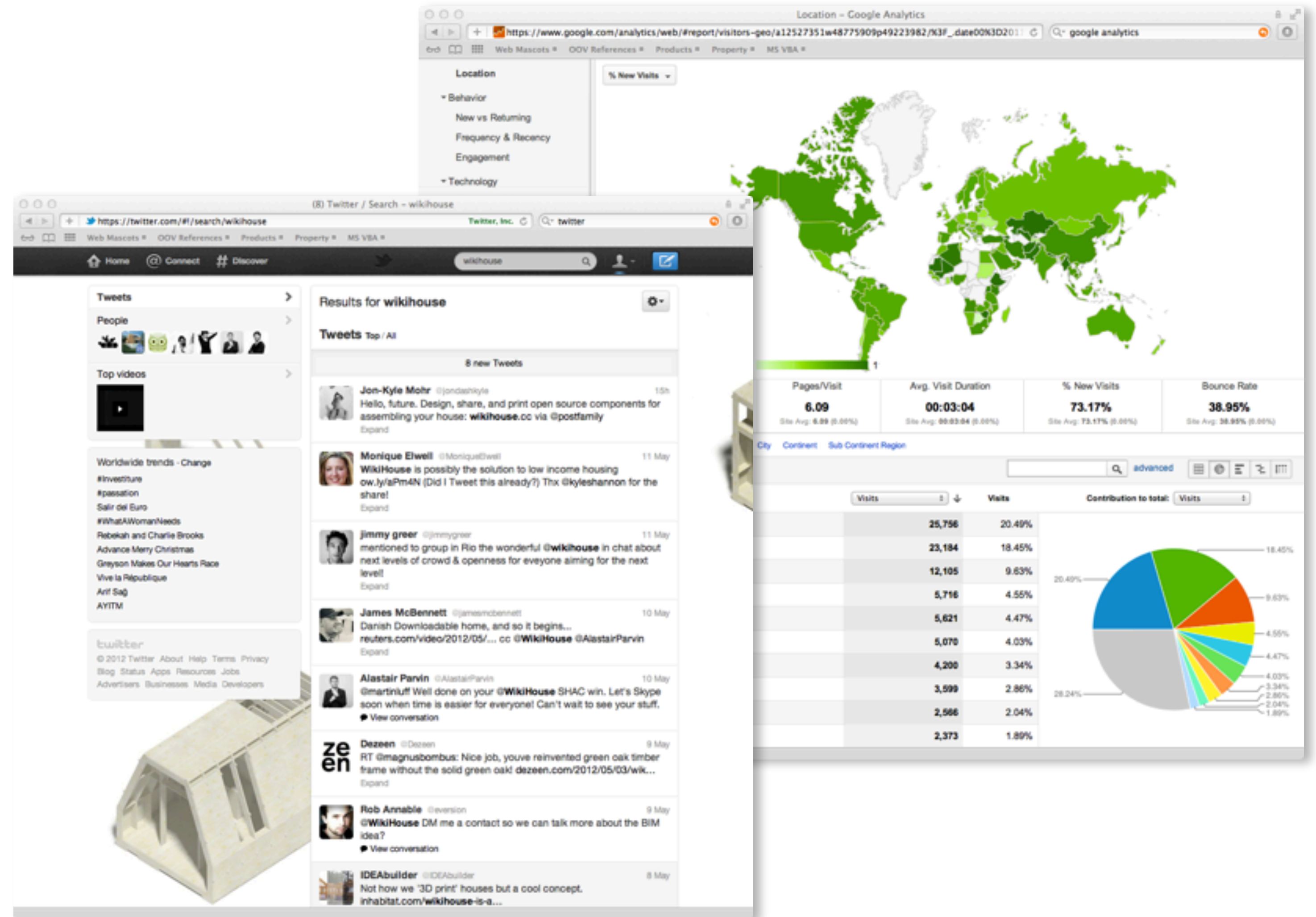

Experiments

We have also developed a series of open source furniture pieces working with the Hub Westminster, and collaborated with a number of other Designers, who have expressed an Interest in the potential benefits of a new collaborative digital design platform

Ver
1.0

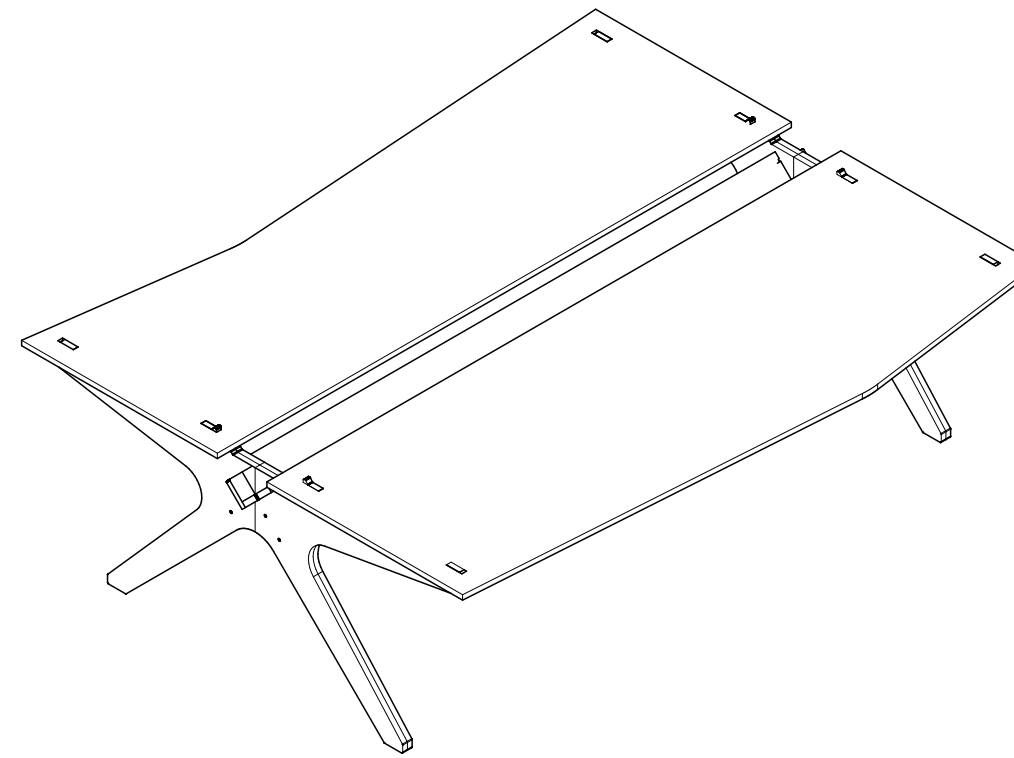

Ver
1.0

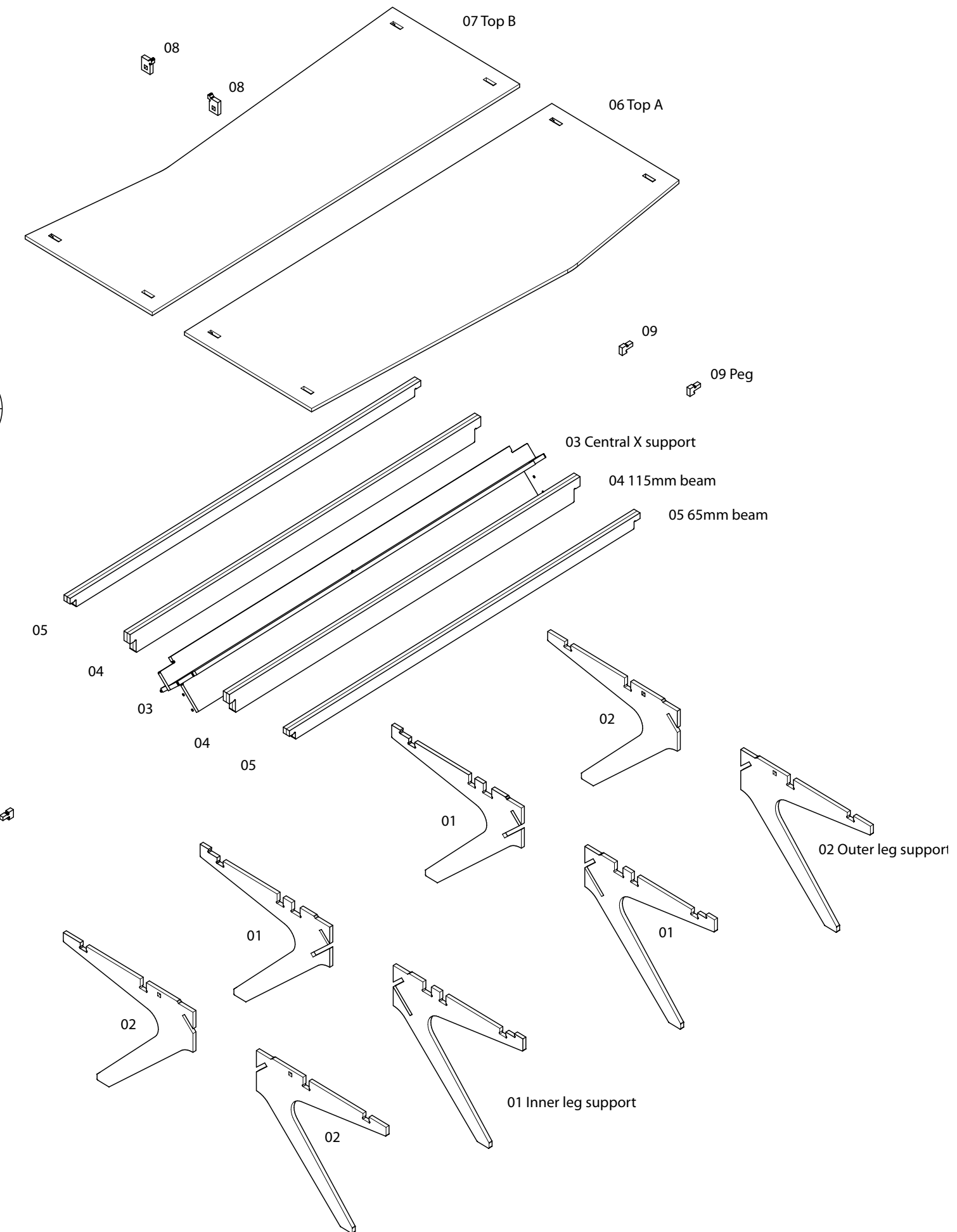

The Free Design Project

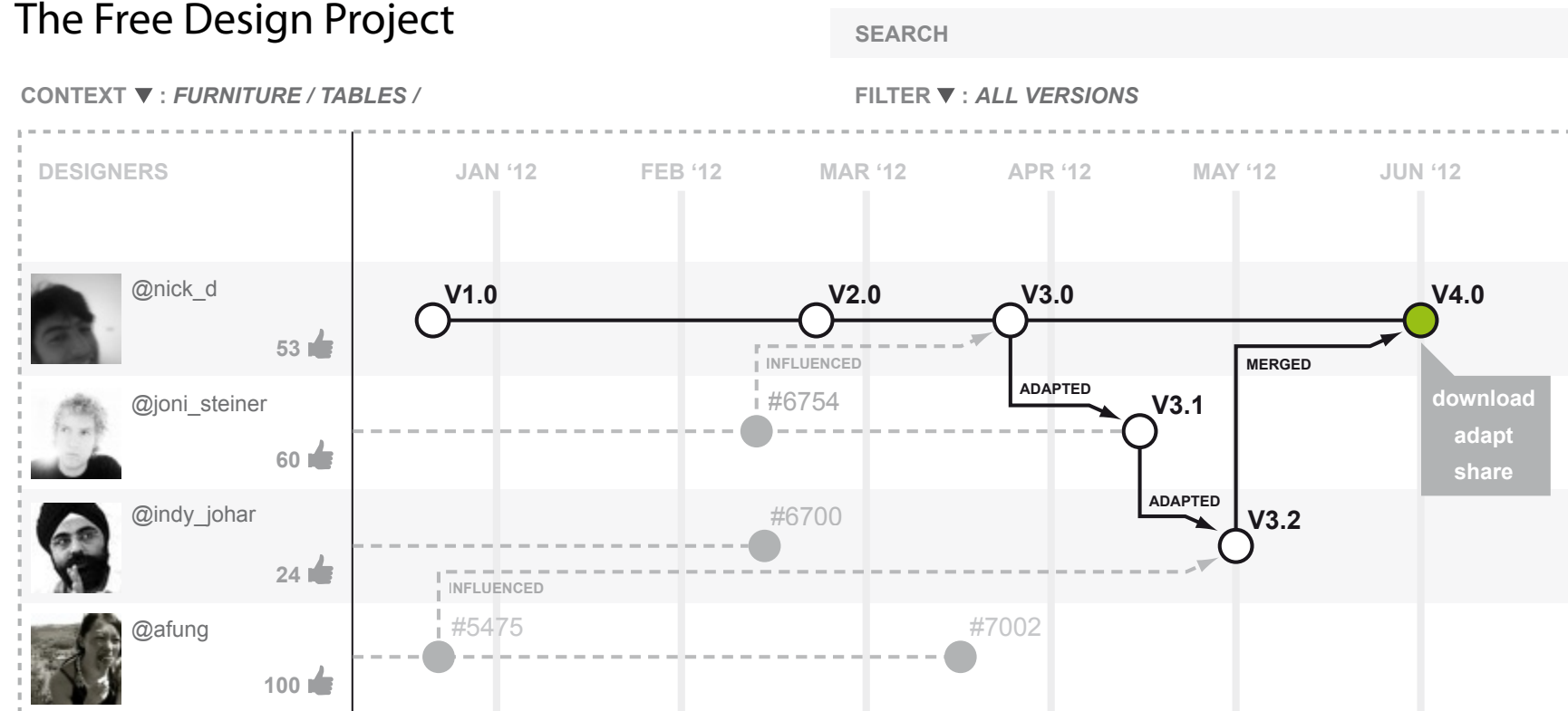

This is our latest version of the table we started in January... Kudos to @joni_steiner and @indy_johar for forwarding the design! I have adopted their table top shapes and added a lock :)

01.06.12 *****



Open source furniture — print it yourself or have it made for you.

[Home](#)
[Designs](#)
[License](#)
[About](#)

Designs / DESK

The original Open Desk, an open-source project commissioned by **Mint Digital**.

The Open Desk is designed as a 4-person workstation. The two profiled desk tops can be rotated to create different working environments, either side of the central cable tray. Simply slotting together, Open Desk can be taken apart and flattened for easy transport. Talk to us about variants and bespoke versions!

Designed by: **Joni Steiner & Nick Ierodiaconou**
Made 1 times

Dimensions: length: 2,200mm, height: 720mm, width: 1,690mm.
Cutting sheets: 4
Material options:

- 100% Birch-faced Plywood
- 50% Wisaboard Laminated Plywood (the top half) / 50% Birch-faced Plywood (the bottom half)

Made by:

- CNC Workshop**
- I.J. CNC Services**

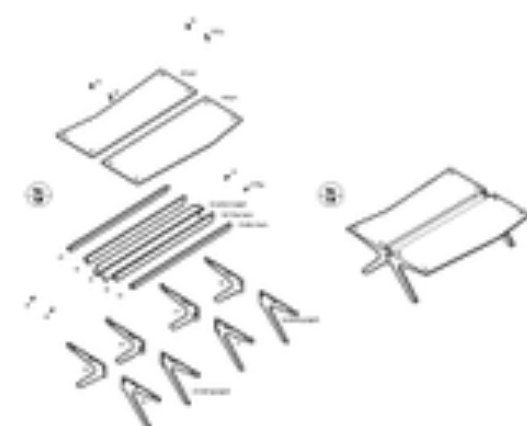
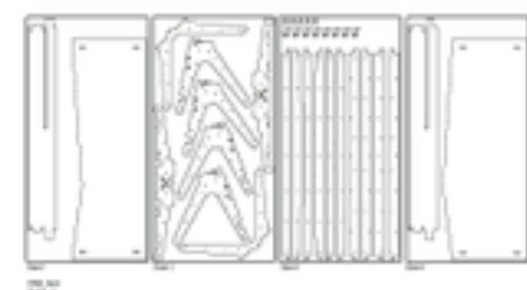

[Make it yourself »](#)
[Get it made »](#)

Design:	£35
Manufacture:	£685-755
VAT & Delivery:	Excl.

TOTAL:	£720-790
---------------	-----------------

[Customise »](#)

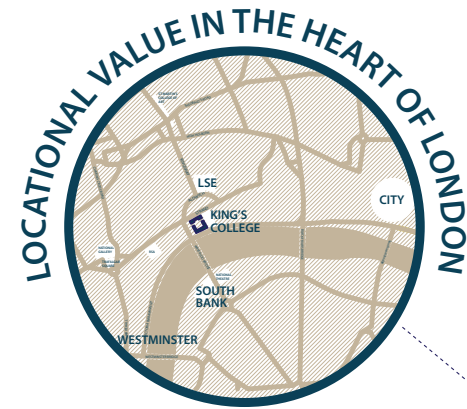
[200,000 SQFT]
OF MICRO ENTERPRISE INCUBATOR SPACE



[1X MICRO VC FUND] SOMERSET EXCHANGE VC FUND READILY AVAILABLE TO INVEST IN ENTERPRISES

£1.5M
RE-INVESTMENT ENGINE INTO THE "MAKE BRITAIN" AGENDA

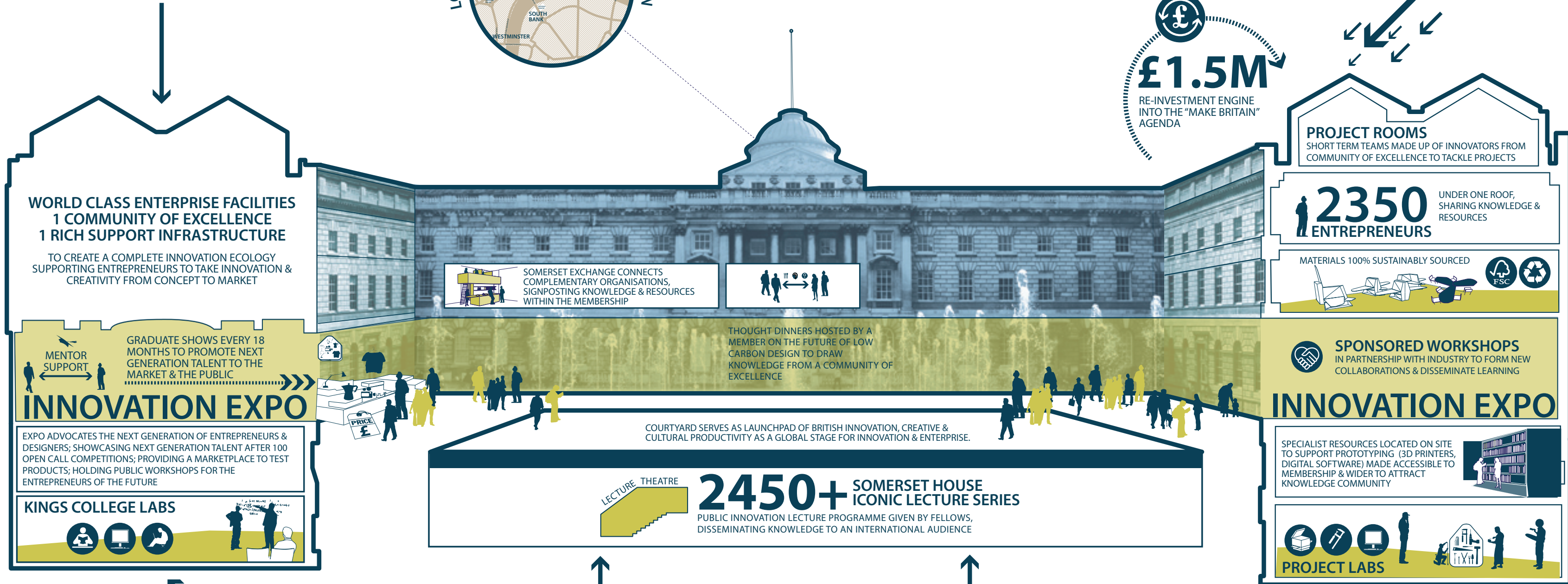

WORLD CLASS ENTERPRISE FACILITIES
1 COMMUNITY OF EXCELLENCE
1 RICH SUPPORT INFRASTRUCTURE
TO CREATE A COMPLETE INNOVATION ECOLOGY SUPPORTING ENTREPRENEURS TO TAKE INNOVATION & CREATIVITY FROM CONCEPT TO MARKET

PROJECT ROOMS
SHORT TERM TEAMS MADE UP OF INNOVATORS FROM COMMUNITY OF EXCELLENCE TO TACKLE PROJECTS

2350 ENTREPRENEURS
UNDER ONE ROOF, SHARING KNOWLEDGE & RESOURCES

MATERIALS 100% SUSTAINABLY SOURCED

SPONSORED WORKSHOPS
IN PARTNERSHIP WITH INDUSTRY TO FORM NEW COLLABORATIONS & DISSEMINATE LEARNING

GRADUATE SHOWS EVERY 18 MONTHS TO PROMOTE NEXT GENERATION TALENT TO THE MARKET & THE PUBLIC

INNOVATION EXPO

EXPO ADVOCATES THE NEXT GENERATION OF ENTREPRENEURS & DESIGNERS; SHOWCASING NEXT GENERATION TALENT AFTER 100 OPEN CALL COMPETITIONS; PROVIDING A MARKETPLACE TO TEST PRODUCTS; HOLDING PUBLIC WORKSHOPS FOR THE ENTREPRENEURS OF THE FUTURE

KINGS COLLEGE LABS

THOUGHT DINNERS HOSTED BY A MEMBER ON THE FUTURE OF LOW CARBON DESIGN TO DRAW KNOWLEDGE FROM A COMMUNITY OF EXCELLENCE

COURTYARD SERVES AS LAUNCHPAD OF BRITISH INNOVATION, CREATIVE & CULTURAL PRODUCTIVITY AS A GLOBAL STAGE FOR INNOVATION & ENTERPRISE.

LECTURE THEATRE
2450+ SOMERSET HOUSE ICONIC LECTURE SERIES
PUBLIC INNOVATION LECTURE PROGRAMME GIVEN BY FELLOWS, DISSEMINATING KNOWLEDGE TO AN INTERNATIONAL AUDIENCE

INNOVATION EXPO

SPECIALIST RESOURCES LOCATED ON SITE TO SUPPORT PROTOTYPING (3D PRINTERS, DIGITAL SOFTWARE) MADE ACCESSIBLE TO MEMBERSHIP & WIDER TO ATTRACT KNOWLEDGE COMMUNITY

PROJECT LABS

[X 10]
SUPPORTING THE BEST OF INNOVATION FROM IDEA TO MARKET
OPEN INNOVATION COMPETITIONS

[X 100]
INVITED FROM THE MOST INNOVATIVE INDIVIDUALS & ORGANISATIONS
GLOBAL FELLOWS

[X 100]
WEALTH OF TALENT & COMMUNITY OF EXCELLENCE ATTRACT INVESTORS
BLACK BOOK INVESTMENT FUND

[]
INVITED TO HOST WORKSHOPS AND PROTOTYPE PROJECTS WITHIN A KNOWLEDGE COMMUNITY
"EXPERT IN RESIDENCE"

Sommerset House / LDN

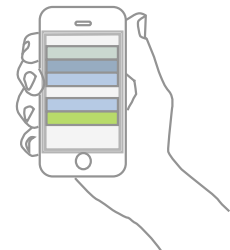

MOBILE ICT

Timetabling
GPS Locating
Working
Teaching Material
Remote access to teaching



STUDENT CARDS

Identification
Access to services and facilities
Managed Payment



UNIFORMS

Visible Identity
All-year weather protection
Reflective



LOCAL BUSES

Transport to school
Transport within school



SCHOOL MINIBUS

Special transport needs
Special transport destinations



SCHOOL BIKES

Visible Identity
Anywhere, anytime transport



PUBLIC REALM

Parks
Toilets
Safety & Security
Cycle Lanes



LOCAL WI-FI

Anywhere web-access

Scale Free Schools

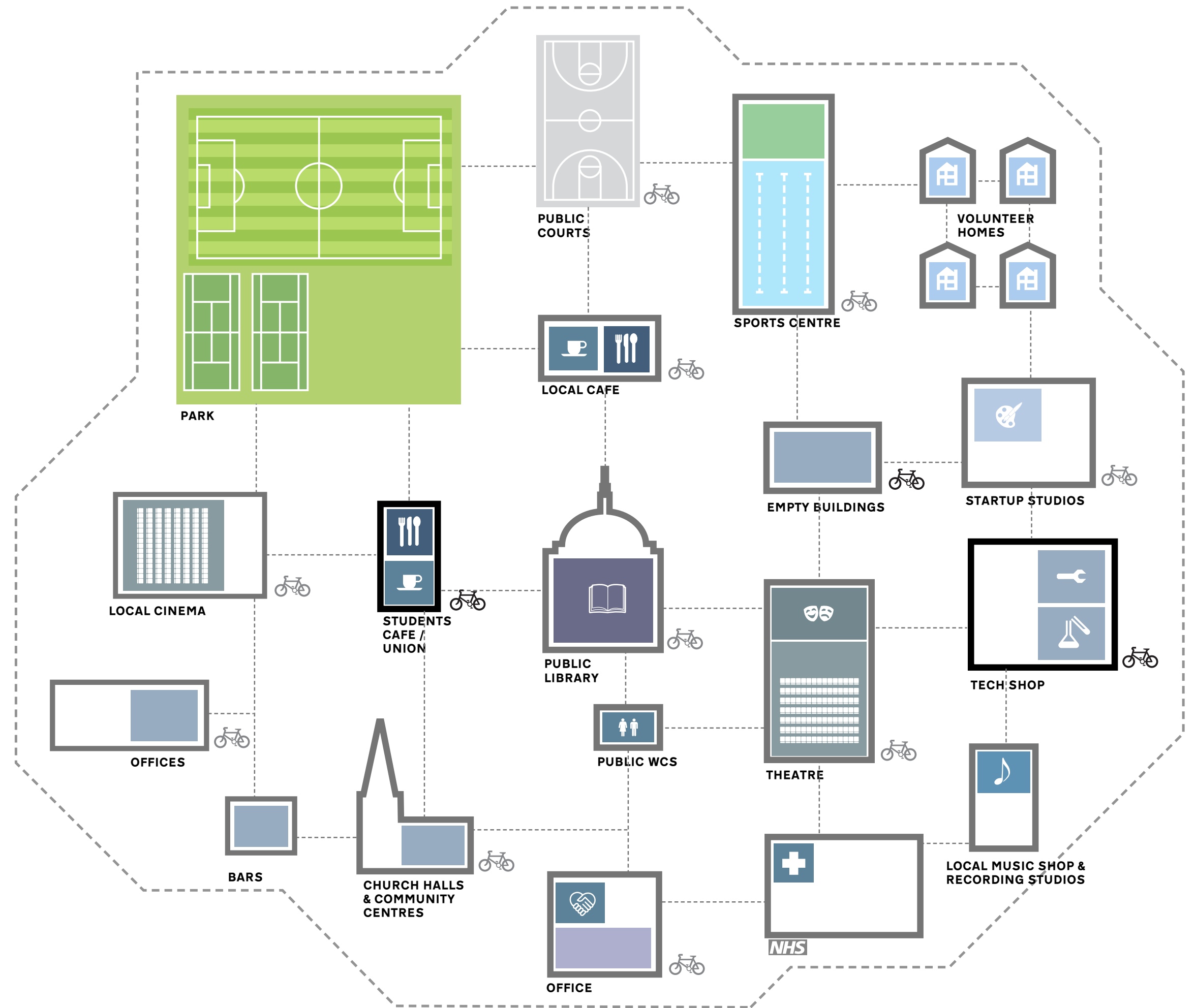

Open Institute / LDN

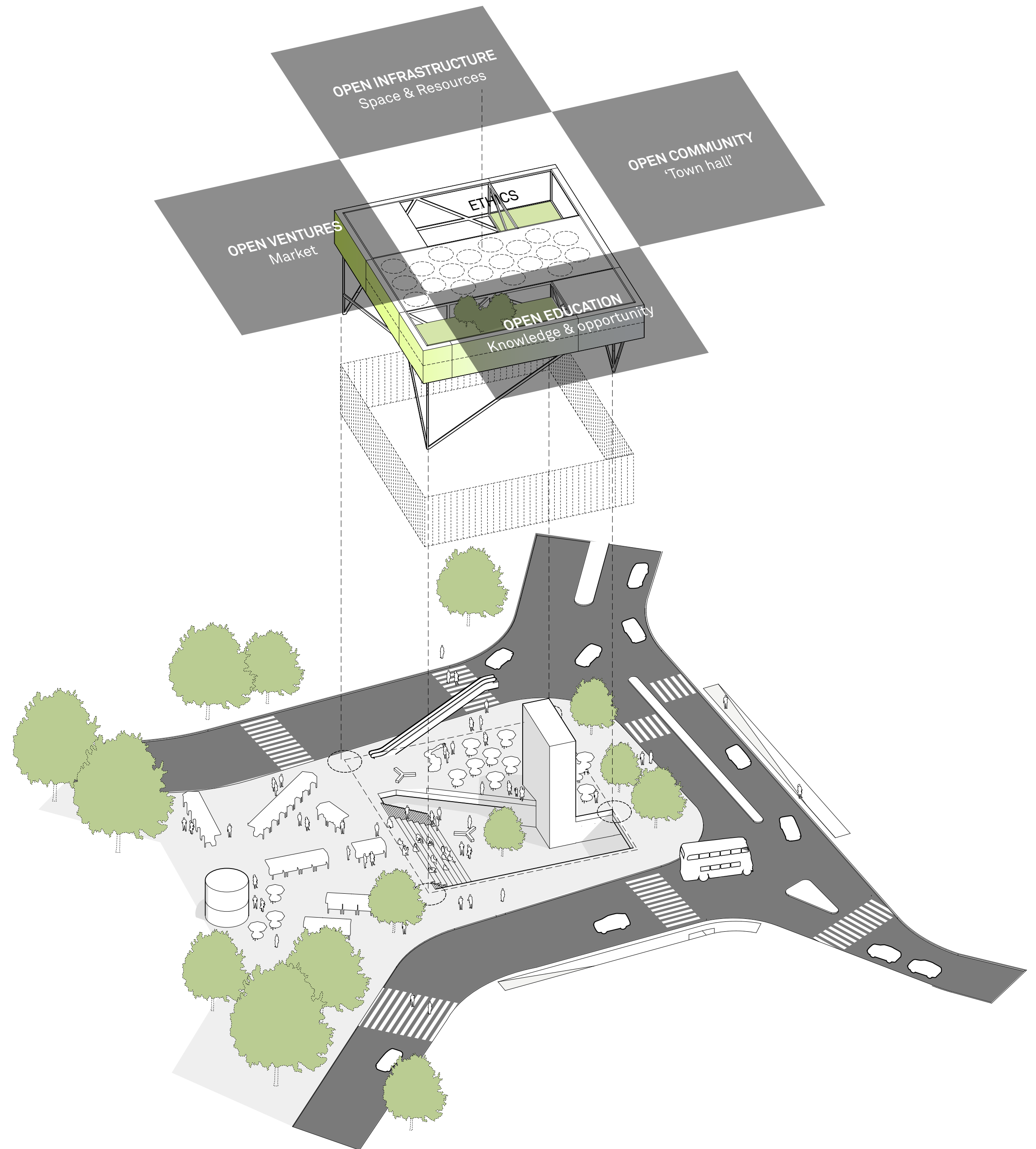



Open Manufacturing

The factory of the future is even cheaper access to digital fabrication printers and CNC machines, it is share, download and fabricate

This is driving a new generation of hardware designs, and a global network which promises to radically de-centralize manufacturing, and make the United States a nation of 'makers'.

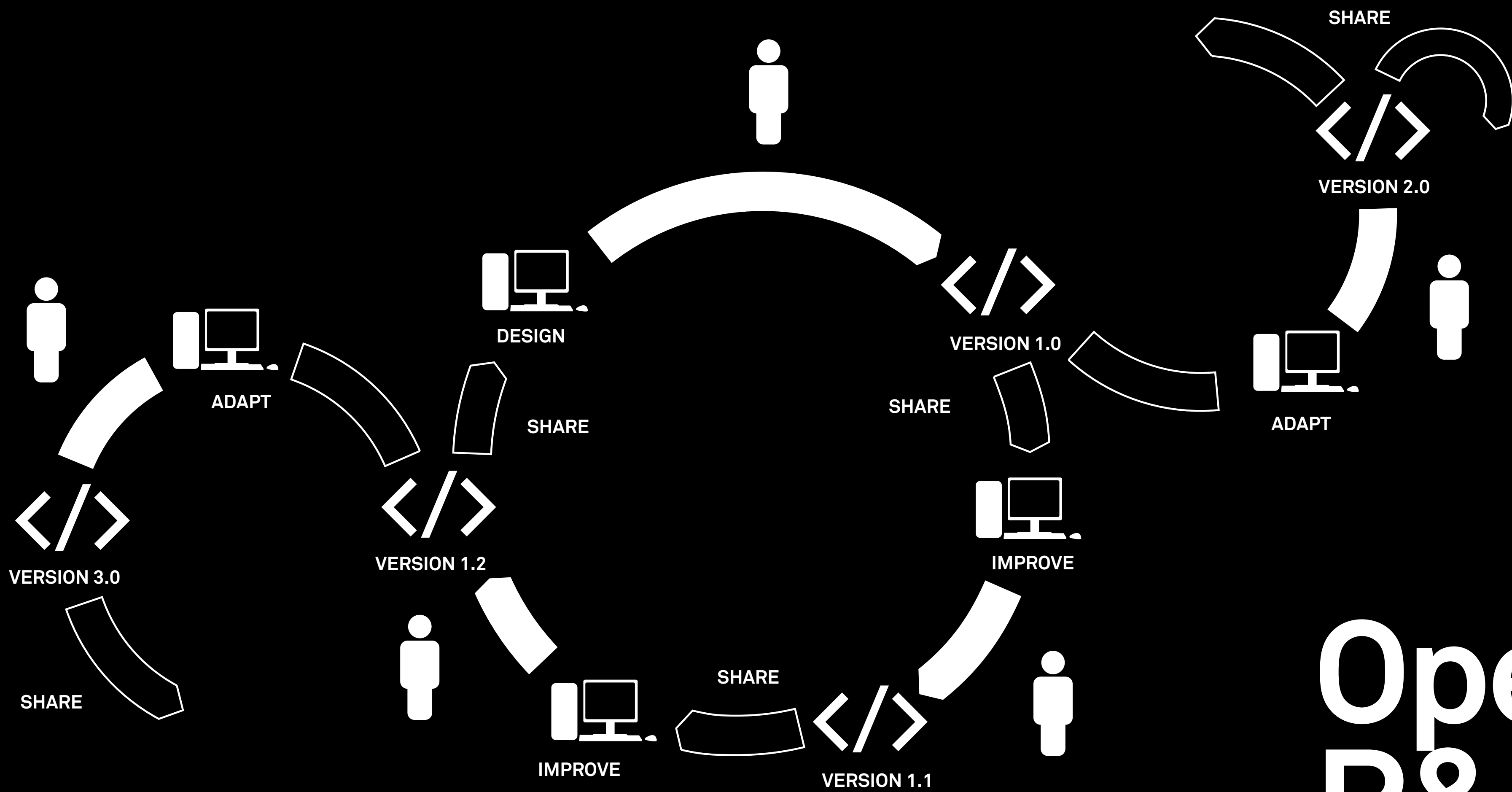
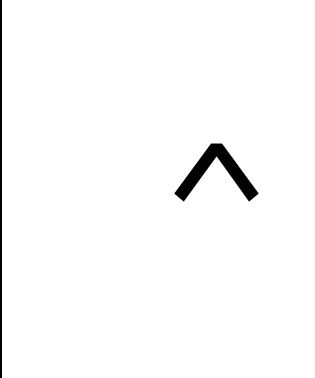

Open R&D

Forking. Communities collaborate by means of copying, adapting, improving and iterating fast – outperforming slow, closed teams. Often the communities consist not just professionals, but users, testing and customising products.

_.Ltd
_.LLP
_.LP
_.PLC
_.CIC
_.CIO

+

_.OLC Open Limited Company

Open Business

Radical Openness. From emerging open business models such as *FabLab*, can we begin to imagine new forms of contract between society and businesses; offering deep transparency, open access and making a scalable contribution to the commons?



Open Gov.



Git-gov With open data forming the foundation for new social enterprises, open apps, and allowing citizens to participate in public services, could the open source platforms and constitutions for mass collaboration be used increasingly to build the software framework of a more participative democracy, including even the drafting of legislation? (For example, *Open City Apps*)

**ADVISORY
Design
Board**

**GLOBAL
OI-Platform.Net**

**ADVISORY
Open
Faculty**

**LONDON
OI-London.Net**

**BIRMINGHAM
OI-Birmingham.Net**

OPEN INVESTMENT
OI-London.Net/investment

OPEN INFRASTRUCTURE
OI-London.Net/Infrastructure

OPEN INQUIRY
OI-London.Net/inquiry

OPEN INITIATIVE
OI-London.Net/initiative

OI LONDON

**LEARNING
PLATFORM**

OPEN SOURCE FACTORY
OPEN CIVICS

OPEN KITCHEN
OPEN HUB

OPEN ACCELERATOR

OPEN INVESTMENT
OI-Birmingham.Net/investment

OPEN INFRASTRUCTURE
OI-Birmingham.Net/Infrastructure

OPEN INQUIRY
OI-London.Net/inquiry

OPEN INITIATIVE
OI-Birmingham.Net/initiative

OI BIRMINGHAM

**LEARNING
PLATFORM**

OPEN SOURCE FACTORY
OPEN CIVICS

OPEN KITCHEN
OPEN HUB

OPEN ACCELERATOR

- OS** OPEN SOURCE
- CC** CREATIVE COMMONS
- OI** OPEN INFRASTRUCTURE
- M** MANUFACTURING
- G** GOVERNANCE
- A** ART
- R** RETAIL
- F** FOOD
- FIN** FINANCE
- D** DESIGN
- £** BUSINESS
- A** ARCHITECTURE
- S** SCIENCE
- L** LOGISTICS
- C** CULTURE
- E** EDUCATION
- T** TECHNOLOGY
- ENV** ENVIRONMENT
- P** POLICY
- G** GOVERNMENT
- D** DATA

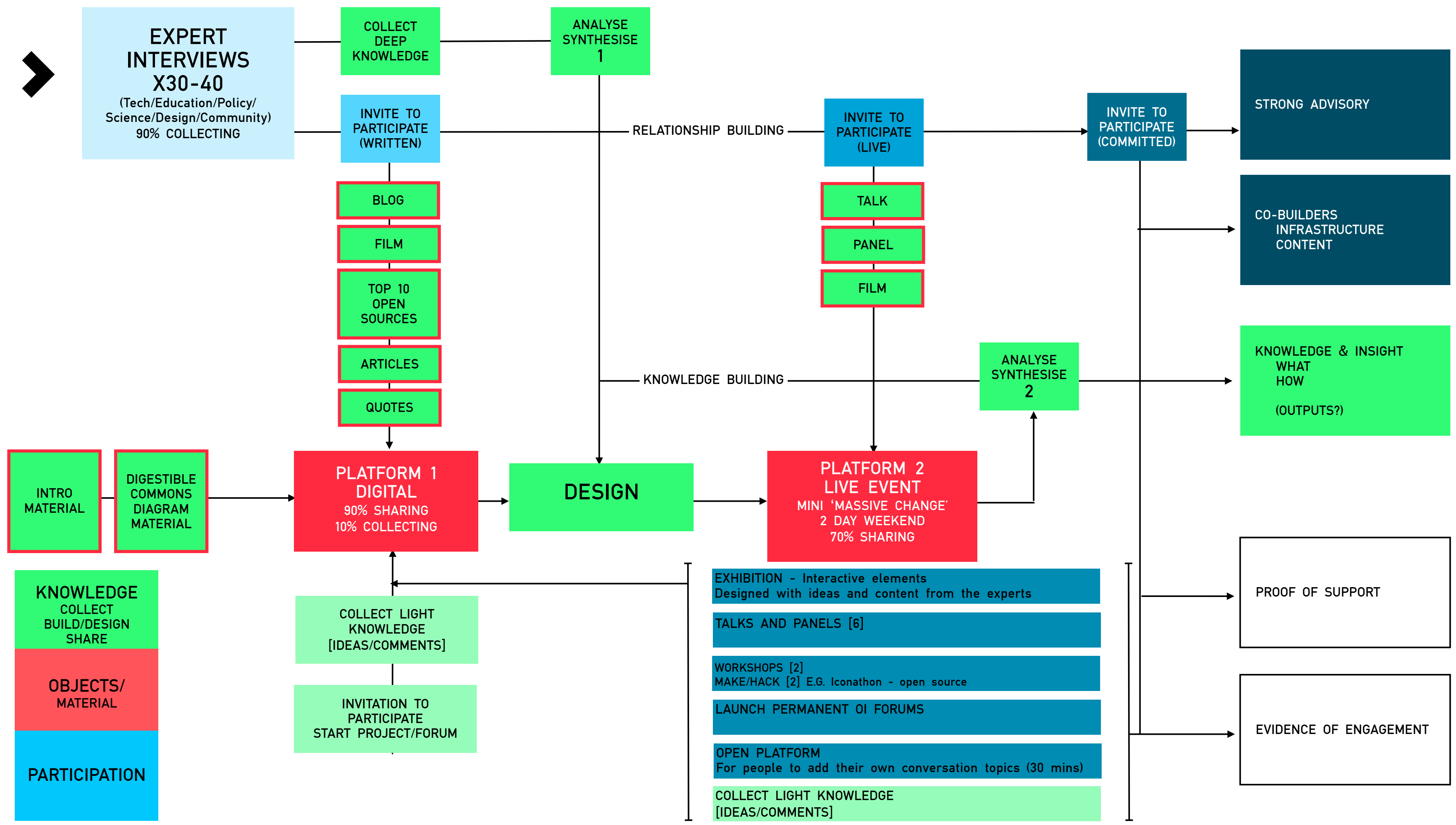

06d/ Open OS.

The platform is conceived not unlike a typical smartphone. It will consist of:

- 1. **Hardware** The physical kit
- 2. **Operating system** (rules and running software)
- 3. **'Apps'** by third parties, such as programmes, uses, events or software. (e.g Hackspace)

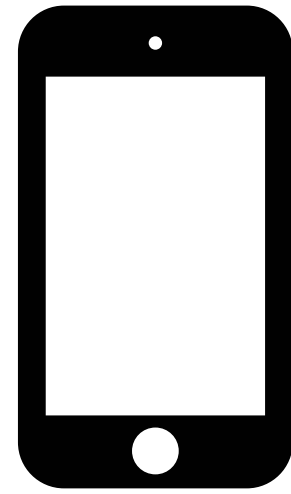

1. FELLOWS

'Professors' as generous thematic knowledge aggregators. Seeds projects, curates networks, open IP.



2. OPEN CURATORS

'Broadcasters' - processing raw data and knowledge and disseminating meaning.



3. OPEN FUND

Investors activating investment both in entrepreneurs and intrapreneurs (innovators within existing corporations & public sector)



4. OPEN LIBRARIAN

Processing open IP, data, and making it useful.



5. OPEN AUDITORS

Data collection, impact analysis, feedback and ethics commentator.



6. HOSTS

Approachable operator in 'concierge' role, helping by co-ordinating, suggesting, introducing and responding to need.

EXECUTIVE TEAM

Operating team responsible for management, operation & maintenance.

THEMATICS

- Design
- Law
- Governance
- Markets
- Technology
- Finance
- Ethics
- Science
- Medicine
- Behaviour
- ...

'APPS' BY THIRD PARTIES

- Labs
- Incubators
- Businesses
- Organisations
- Education programmes
- Events
- Lectures
- Civic surface
- Web
- Mobile
- ...

HUB Launchpad

Hub Accelerator Programme

DATASCIENCE INCUBATOR



ASSETS & RESOURCES

HUB WESTMINSTER INCUBATOR INFRASTRUCTURE

HUB Westminster

- 12,000 sq ft work, meeting and event space in central London
- Academy at the Hub learning programme
- community of 450 social startups
- 160+ work seats
- 10,000 + CRM database
- 10 FTE Hub Westminster team
- Business Information Point services (with Westminster Reference Library)

HUB LAUNCHPAD TEAM

 london incubation	 external partnerships
 loan management	 learning & research
 open data models	 marketing



DATASCIENCE INNOVATION INCUBATOR LAUNCH PERIOD

1 X 48 HOUR DATASCIENCE INNOVATION THEME CAMP

A 48 hour hack event for 100 persons hosted by IIT & ISI on Datascience Innovation solutions.

Raise awareness of incubator programme and recruitment drive for night and full time accelerator programme.

Recruit from existing membership base of 1000 Hub London members & existing IIT & ISI networks.

Engage wider public services sector and community.



DATASCIENCE INNOVATION NIGHT ACCELERATOR (stage 1)

3 MONTH SCHOLARSHIPS X 100 PERSONS

3 month membership to Hub Westminster providing access to :

- 12,000 sq ft workspace
- startup community of 450 members
- Academy business development classes
- mentoring by IIT & ISI incubator team
- programme of night accelerator events & learning programme by IIT & ISI incubation team

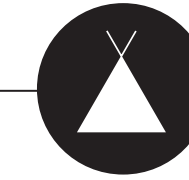

DATASCIENCE INNOVATION THEME CAMPS (stage 2)

1 X 48 HOUR DATASCIENCE INNOVATION THEME CAMP

A 48 hour hack event for 100 persons hosted by IIT & ISI on Datascience Innovation solutions.

Raise awareness of incubator programme and recruitment drive for night and full time accelerator programme.

Engage wider public services sector and community.



DATASCIENCE INNOVATION FULL TIME ACCELERATOR (stage 3)

14 WEEK FULL TIME ACCELERATOR

 x 55 (min 2 person teams)

 £2350 4 month stipend per founder

Accelerator programme provides:

- 14 week membership at Hub Westminster with access to 12,000 sq ft workspace
- monthly stipend of ₹2350 per month per founder
- startup community of 450 members
- learning and development programme by IIT & ISI incubator team
- access to sector / industry mentors
- access to Hub Westminster programme resources ie Academy business development classes



INVESTMENT PRIZE

FINAL PITCH DAY & INVESTMENT AWARDS

Pitch event with 4 Peer Investment Awards and 1 Investor Investment Award.

 1 x ₹8,500
1 x ₹6,000
1 x ₹4,500
1 x ₹2,000

peer investment awards

 1 x ₹25,000
investor investment awards



THE GREAT DISRUPTION

MICROMASSIVE



FROM

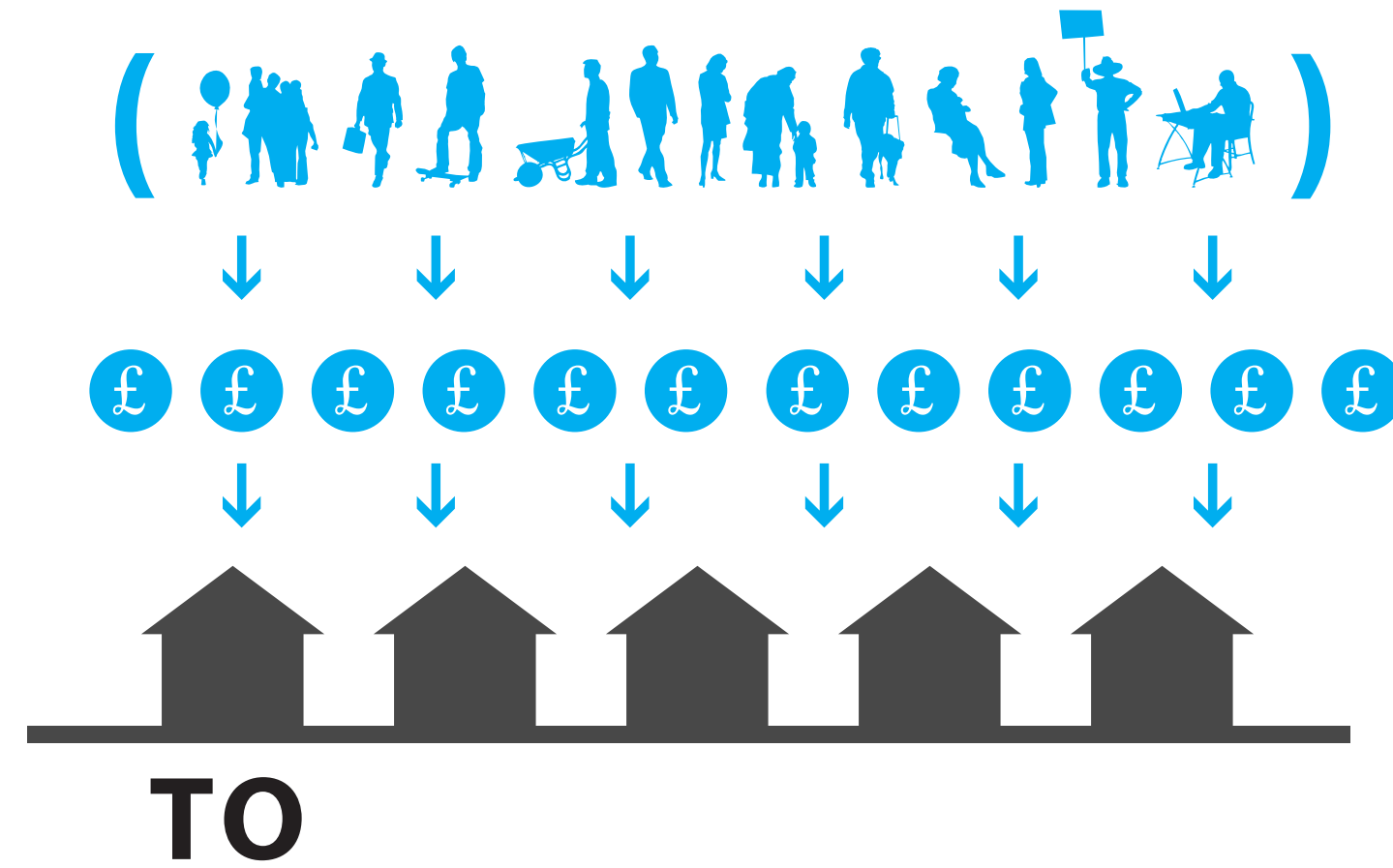

// KEY BEHAVIOURS

ITS ALL ABOUT THE COMMUNITY

COMMUNITY BUILDING

OR

BUILDING COMMUNITY



COMMUNITY BUILDING

&

BUILDING COMMUNITY

tactical innovation

social organisation

// KEY BEHAVIOURS

A NEW SOCIAL CONTRACT



// KEY BEHAVIOURS

ECO_SYSTEM DESIGN



AMBIENT / CONDITION SETTING
CREATING AMBIENT CONDITIONS TO INCREASE THE OPPORTUNITY OF DIRECT AND INDIRECT ENGAGEMENT OF CITIZENS OF VARYING ACTIVE INVOLVEMENT IN THE COMMUNITY HUB AND WITH OTHER CITIZENS



PROGRAMME
USE OF PROGRAMME, FROM STRUCTURED TO INFORMAL EVENTS & CLASSES ETC TO BRING INDIVIDUALS TOGETHER, CREATE COMMONALITY & INCREASE EDUCATIONAL ASPIRATION OF THE COMMUNITY



PLATFORM
INFRASTRUCTURES SUCH AS A LOCAL NEWSPAPER OR ONLINE BOOKING SYSTEM THAT ENABLES VOLUNTEER TYPES, GIVING THEM A PATHWAY TO ENGAGE EG THROUGH CONTRIBUTION OF TIME OR WRITING AN ARTICLE



INSTITUTION
CREATING THE GOVERNANCE STRUCTURES TO ENABLE INDIVIDUALS WITH AGENCY TO ACTIVELY DIRECT THE SYSTEM EG A STEERING GROUP TO MAKE DECISIONS, OR COMMITTEE TO ORGANISE VOLUNTEERS

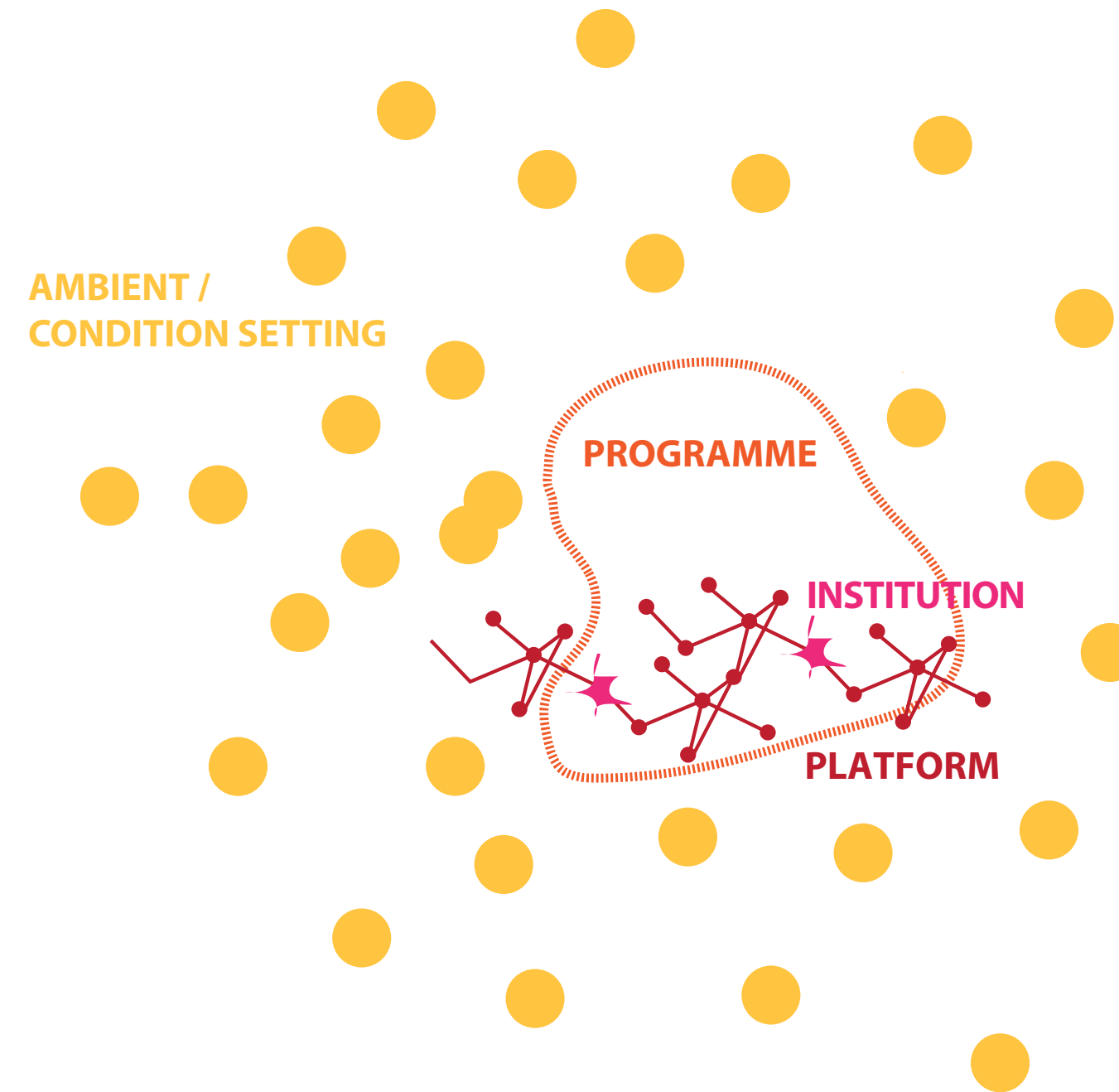

// KEY BEHAVIOURS

PURPOSE DRIVEN SYSTEMS

SECTOR BY SPECIALISATION

STABLE / PREDICTABLE ENVIRONMENT

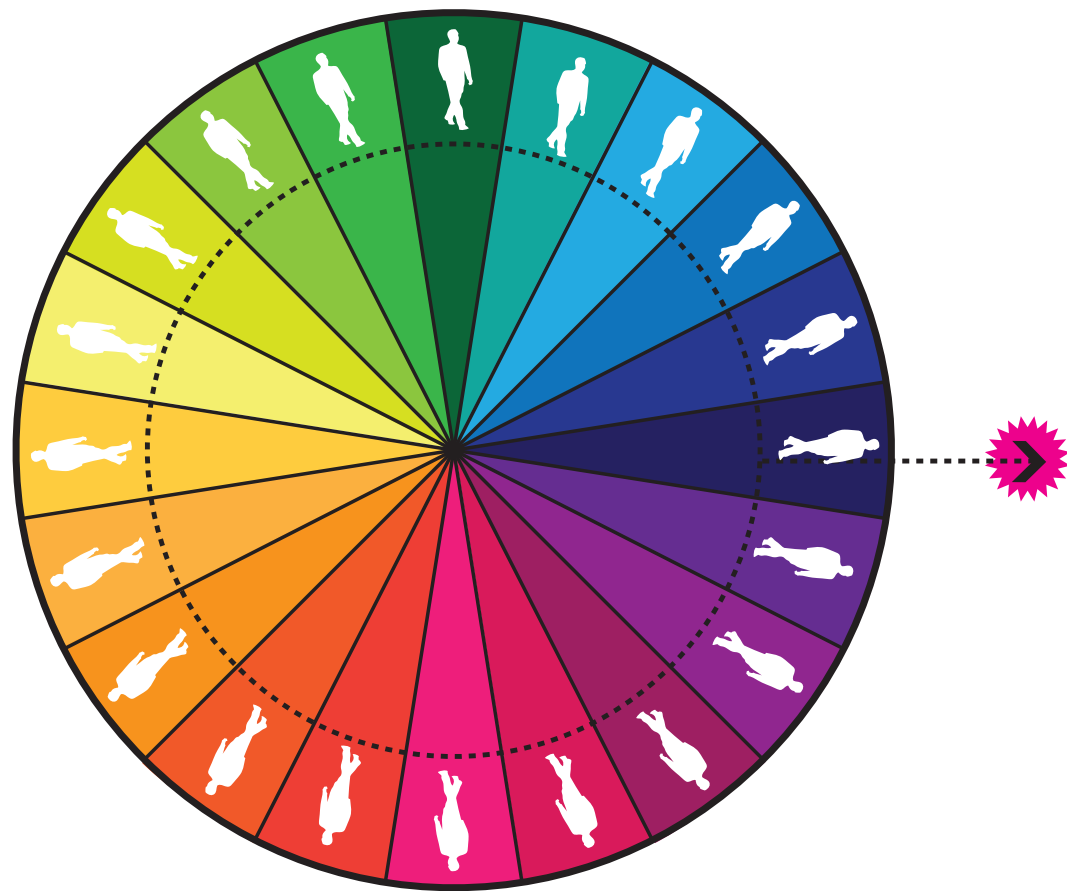

- HIGHER NUMBER OF THRESHOLDS TO OVERCOME
- MORE TRANSLATION NEEDED
- MORE POINTS OF TRANSACTION NEEDED TO ACHIEVE A GOAL
- CIRCUITOUS PATH UNSUITABLE FOR INNOVATION / KNOWLEDGE STYLE WORK

SECTOR BY INDIVIDUAL CAPABILITY

UNSTABLE / UNPREDICTABLE ENVIRONMENT

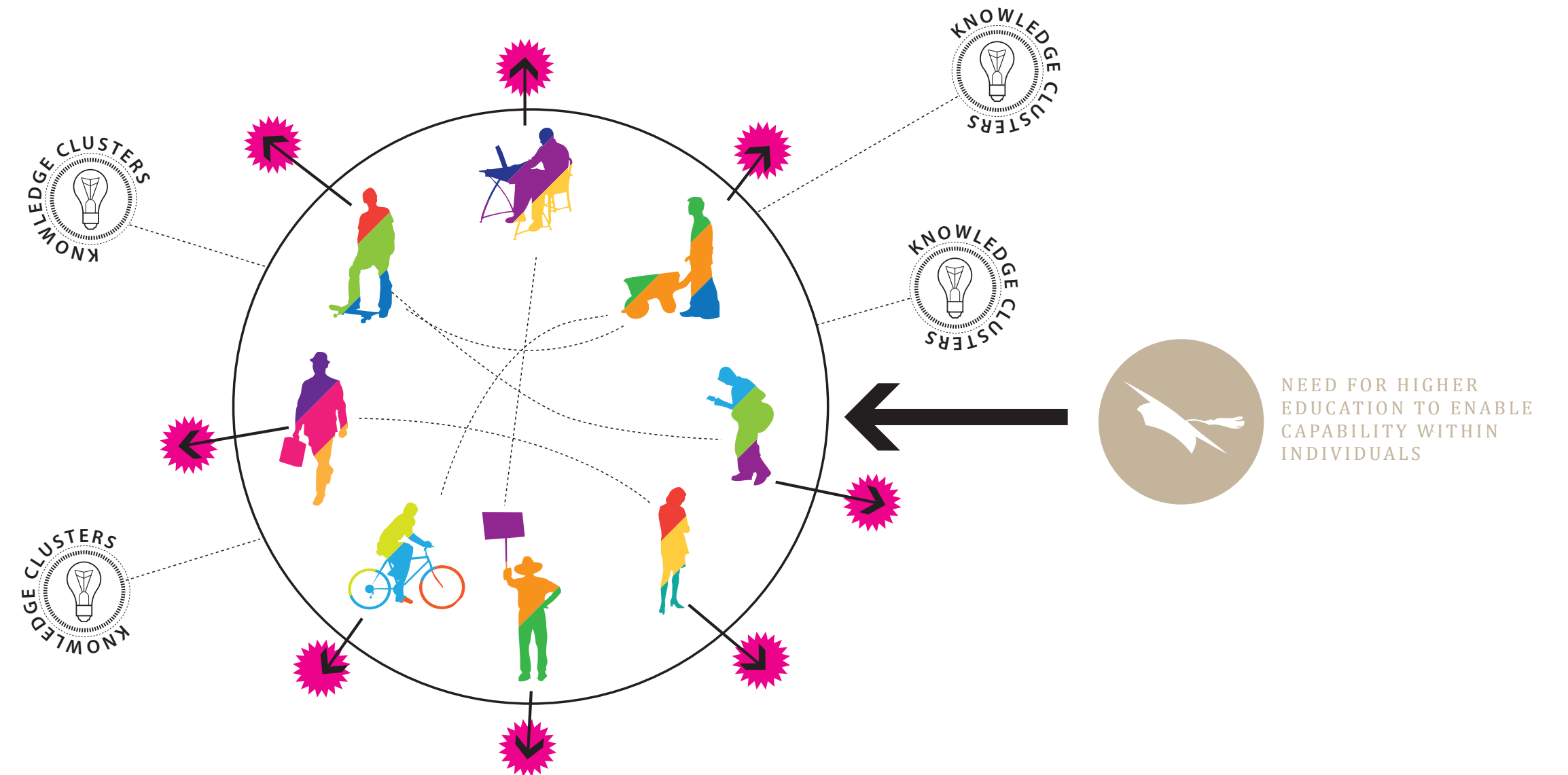

- INDIVIDUALS WITH MULTIPLE CAPABILITIES
- LESS THRESHOLDS ENABLES ACCELERATED ITERATION OF IDEAS, KNOWLEDGE & PROJECTS

// KEY BEHAVIOURS

IMPLICATIONS FOR
PRACTICE

SOCIAL HYDRA.....



// KEY BEHAVIOURS

ROLE SHIFTS | CAPABILITIES



**PROCESS
DESIGNER**



**LOCAL 2.0
TECHS**



**COMMUNITY
PARTICIPATION
DESIGN**



URBAN DESIGN



**LOW CARBON
ARCHITECTURE**



ARCHITECT



**PROJECT
ARCHITECT**



**URBAN
GEOGRAPHER**



ARCHITECT



ANTHROPOLOGIST



ETHICIST

SOME EMERGING DESIGN SKILL SETS



**COMMUNITY
BUILDING**

+

**CO CREATION
PROCESS**

+

**POLITIC
OF
CHANGE**

FROM LINEAR TO SYSTEM NARRATIVES

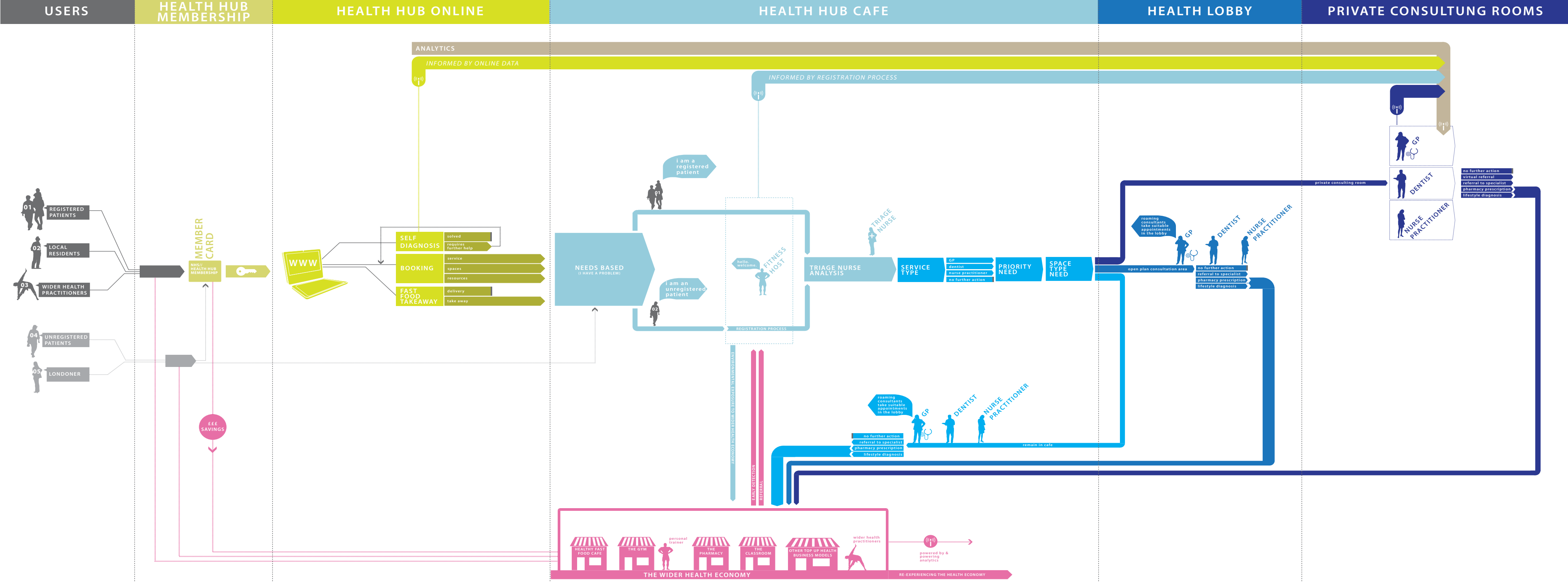

THE POLITICS OF CHANGE

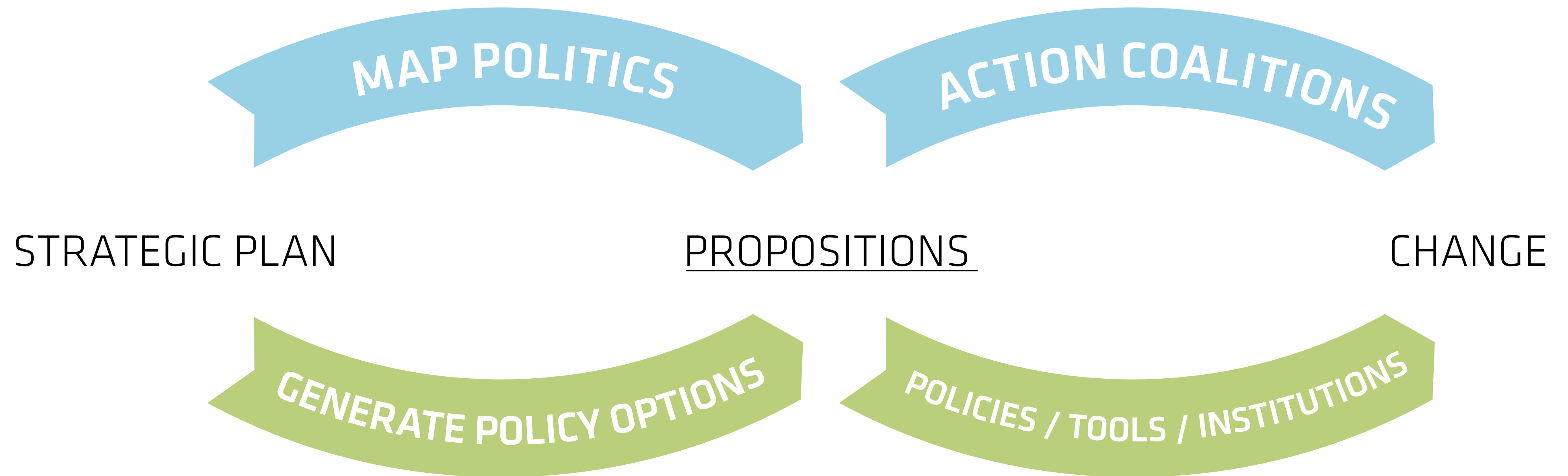

DESIGN ECOSYSTEMS NOT OBJECTS

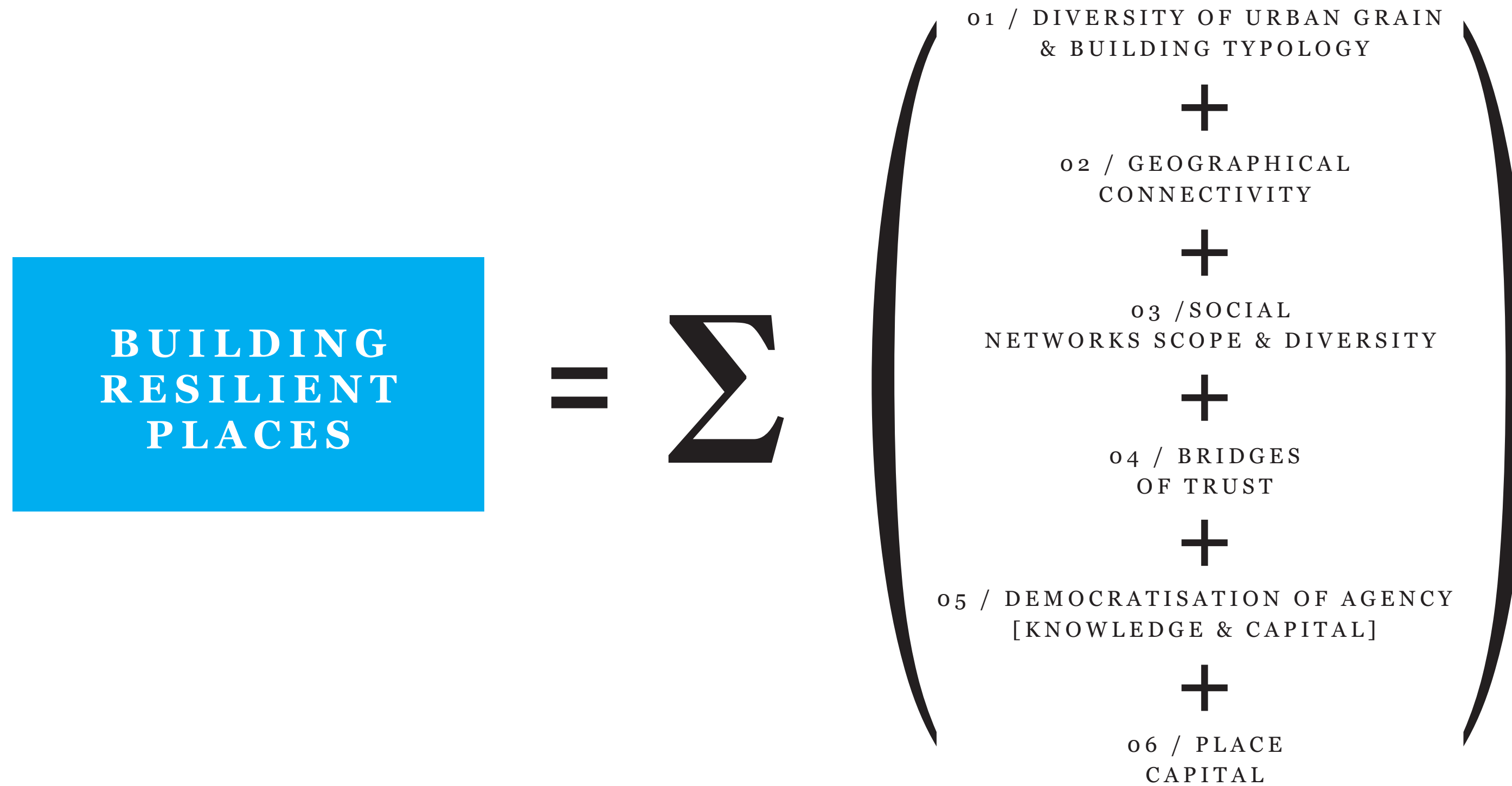

FROM ELEVATIONS TO ECOSYSTEMS

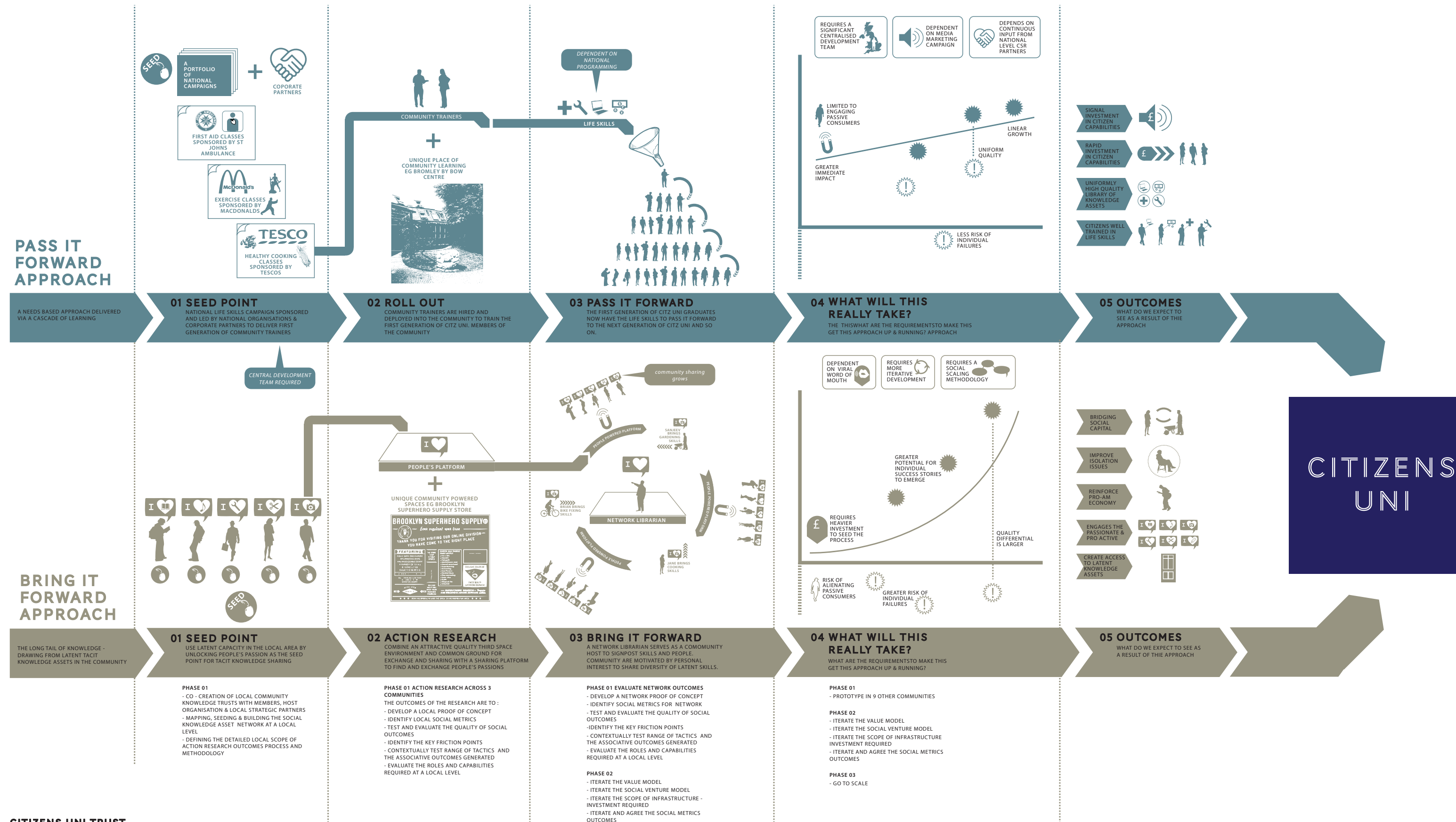



00: //

'Zero Zero '
Hub Westminster
New Zealand House
80 Haymarket
London
SW1Y 4TE

T 0207 739 2230
www.architecture00.net

