

The Multidimensional Wisdom of Crowds

Peter Welinder

California Institute of Technology

Steve Branson

Serge Belongie

Pietro Perona

Indigo Bunting



Search

Photos | Groups | People

Everyone's Uploads

indigo bunting

SEARCH

Full Text | Tags Only
Advanced Search

Sort: Relevant | Recent | Interesting

View: Small | Medium | Detail | Slideshow



From I Bird 2



From The Nature...



From Momba...



From davidcreebir...



From naturelover2...



From K_Alinka



From davidcreebir...



From William ...



From violetfm



From jbobbe



From RitaK.



From mayalu



From ff151



From prairiedog



From redow



From ajnaturephot...



From Ken...



From R Hanson



From [Christine]



From davidcreebir...



From reemac640

5,926 results

6000 images
from flickr.com



Building datasets

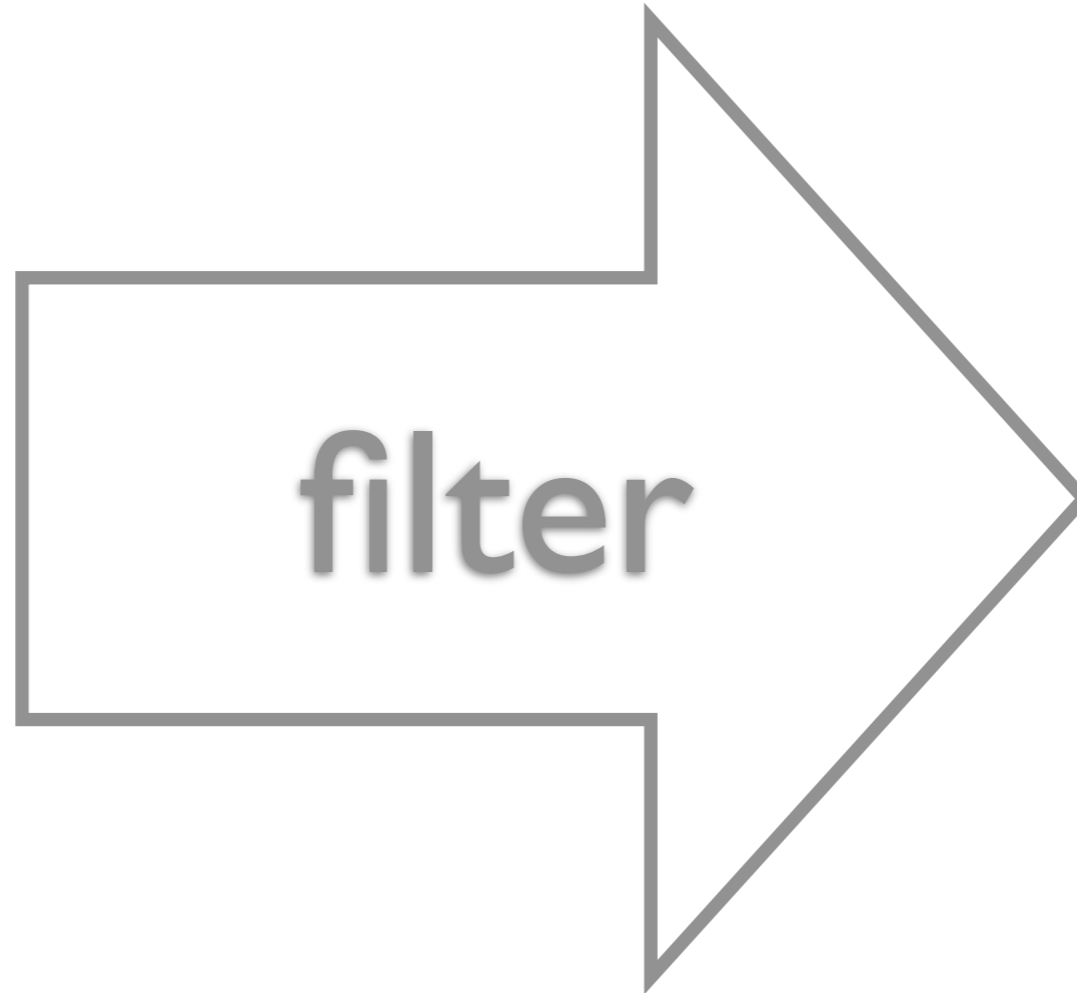

100s of
training images



6000 images
from flickr.com

Building datasets

100s of
training images

Annotators

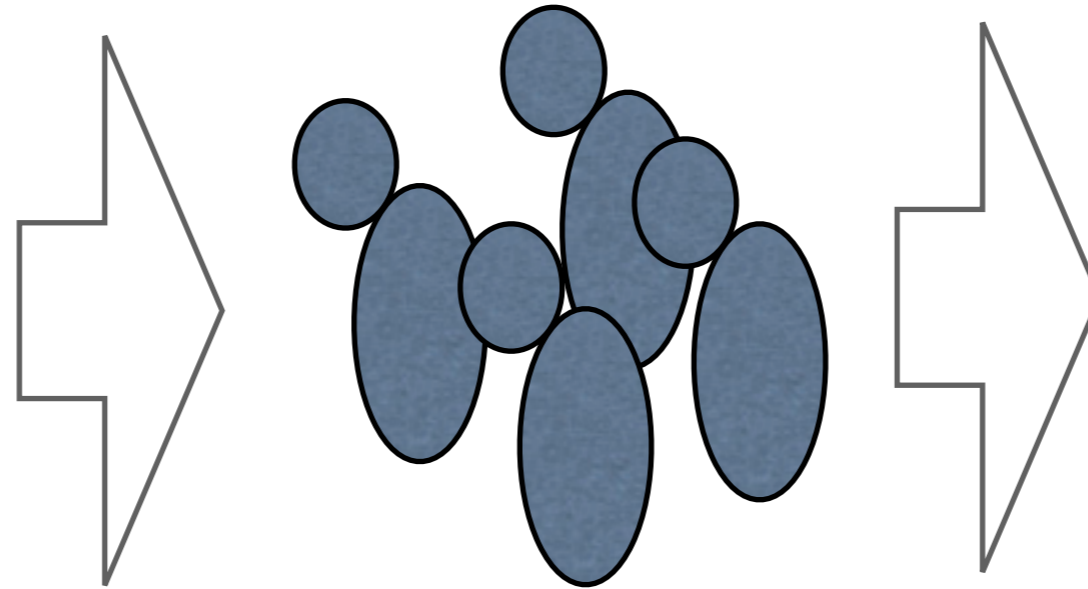

amazonmechanical turk
beta Artificial Intelligence

Is there an Indigo bunting in the image?

Find the Indigo Bunting



Find the Indigo Bunting



A



A



A



A



A



A

Find the Indigo Bunting



A B C D



A B C D



A B C D



A B C D



A B C D



A B C D

Strategies for binary labels

- **Heuristics:**

- Majority
- Traps
- Qualifications



- **Model annotators:**

- Dawid and Skene (1979)
- Raykar et al. (2009)

- **Model image difficulty:**

- Whitehill et al. (2009)

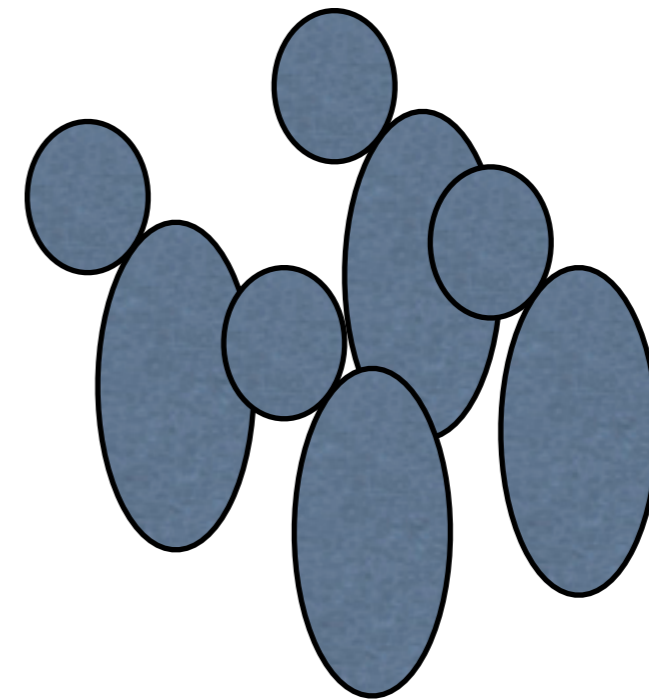

Characterizing annotators: types of errors

Indigo Bunting?

Yes

No



Hit

Miss

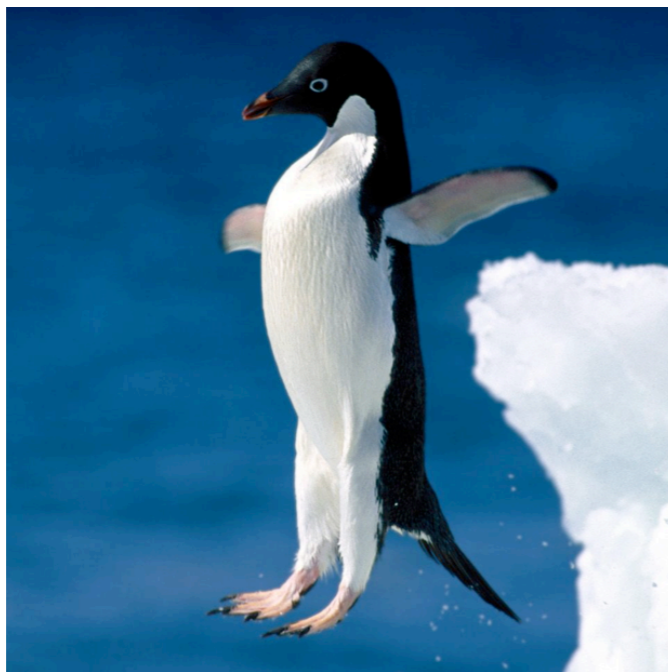

False Alarm

Correct
Rejection

Task: Find the Indigo Bunting

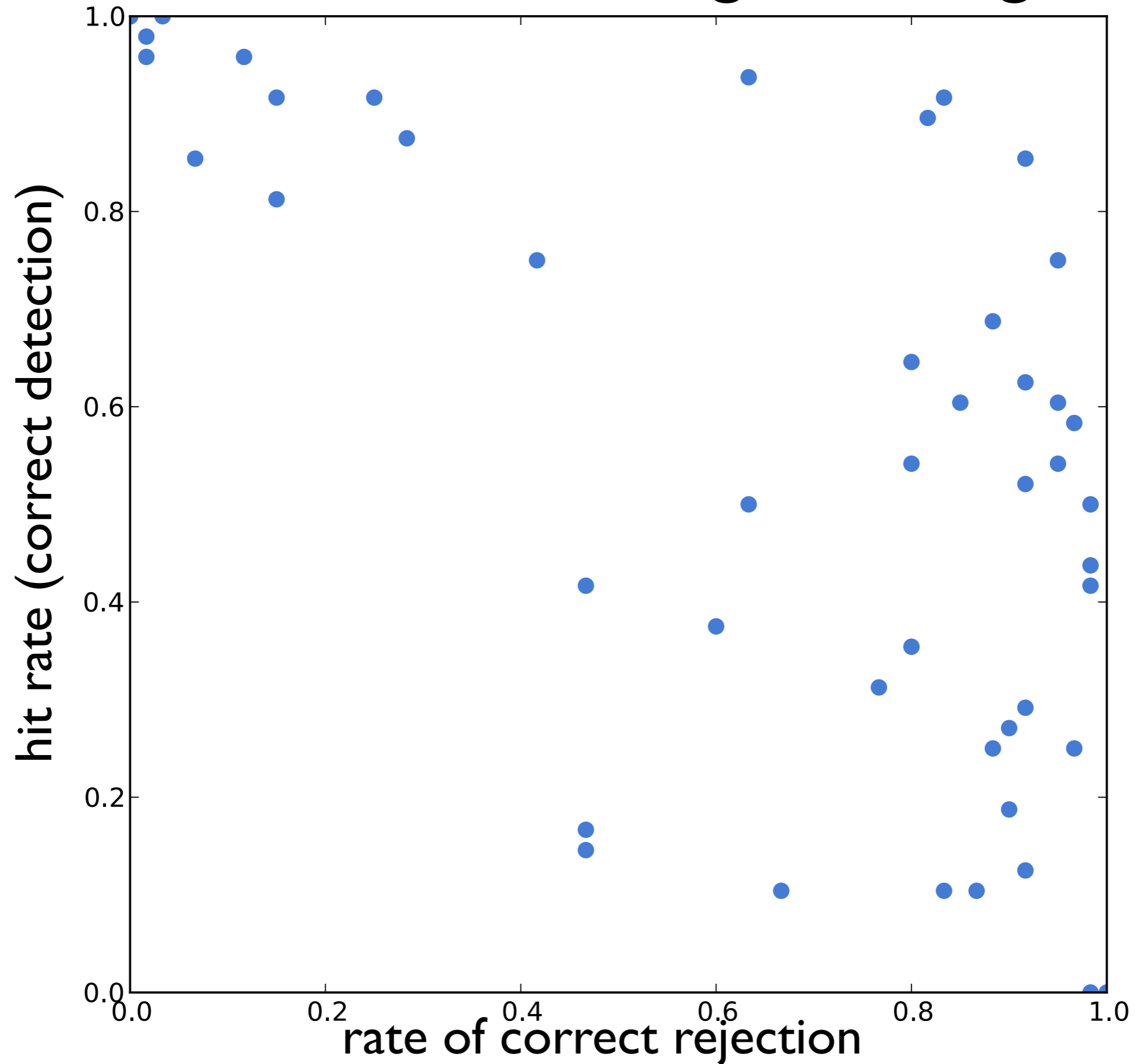

Task: Find the Indigo Bunting

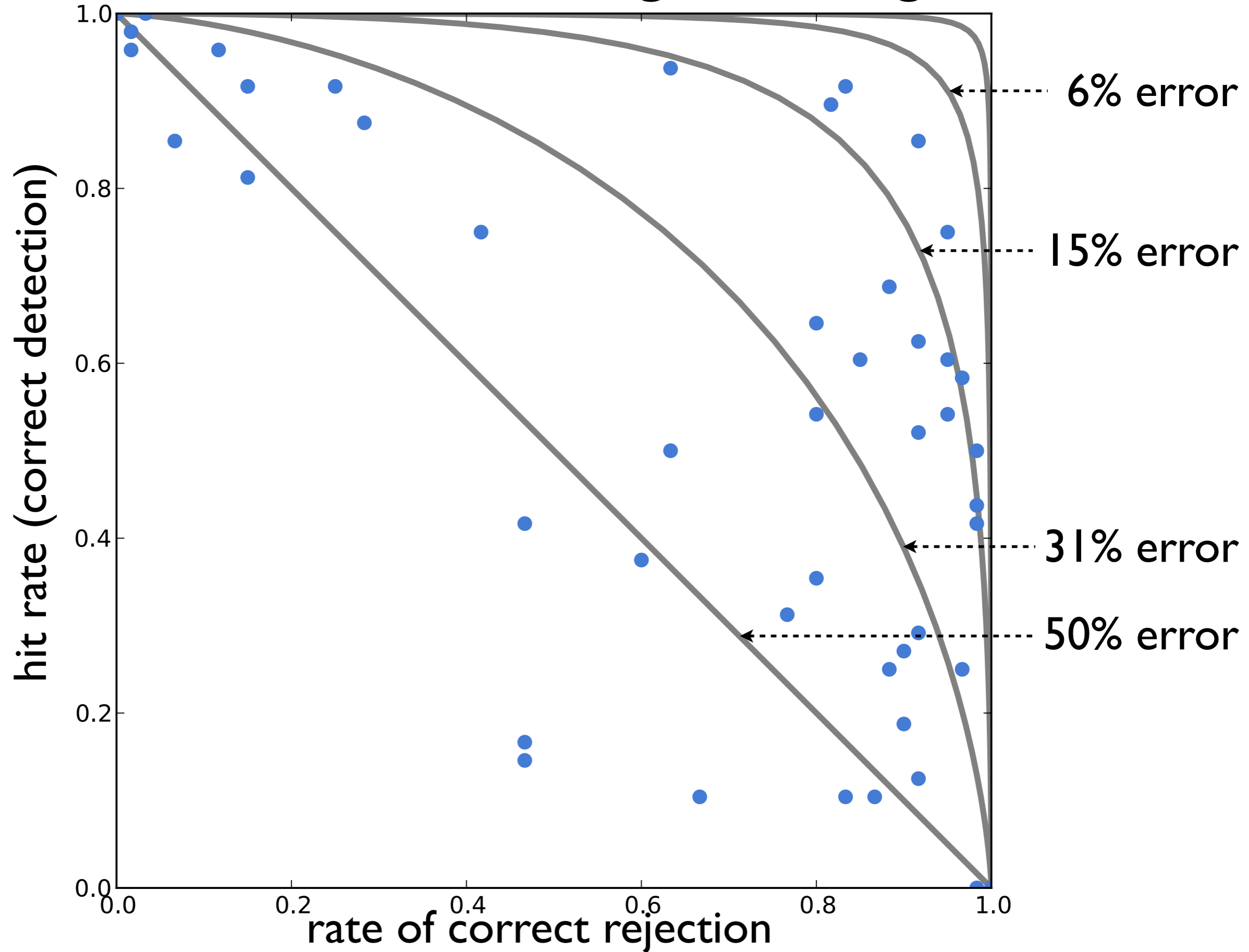

Task: Find the Indigo Bunting

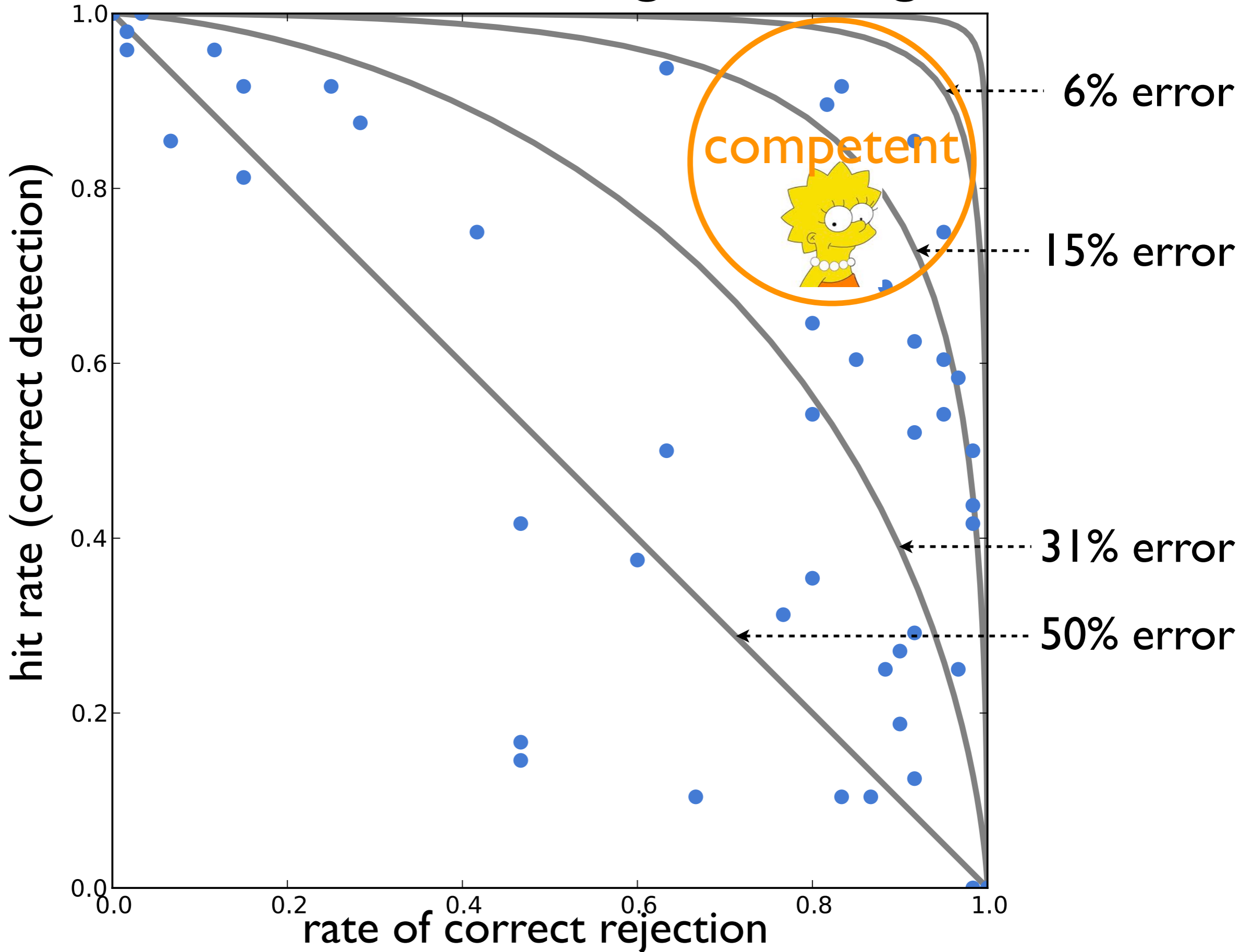

Task: Find the Indigo Bunting

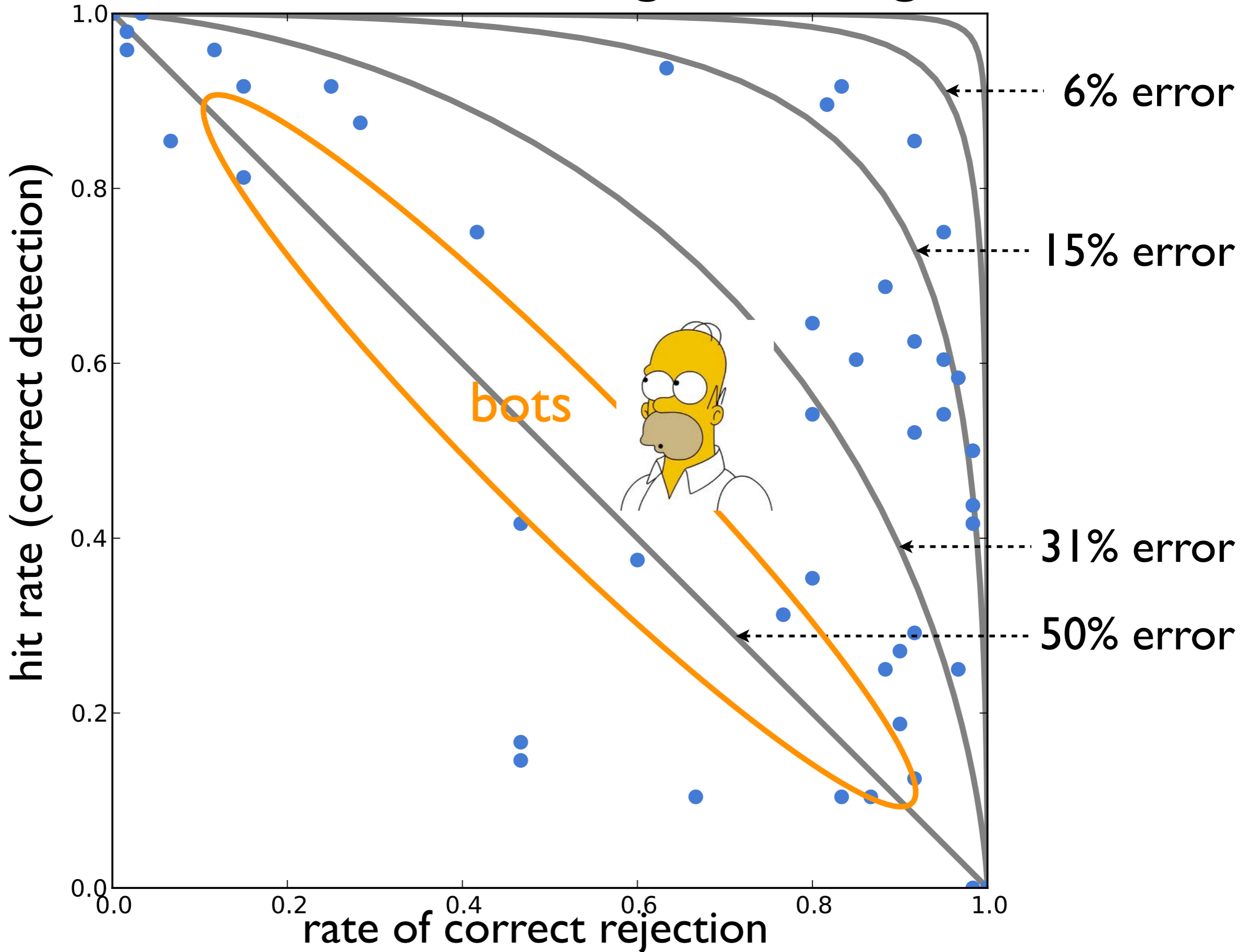

Task: Find the Indigo Bunting

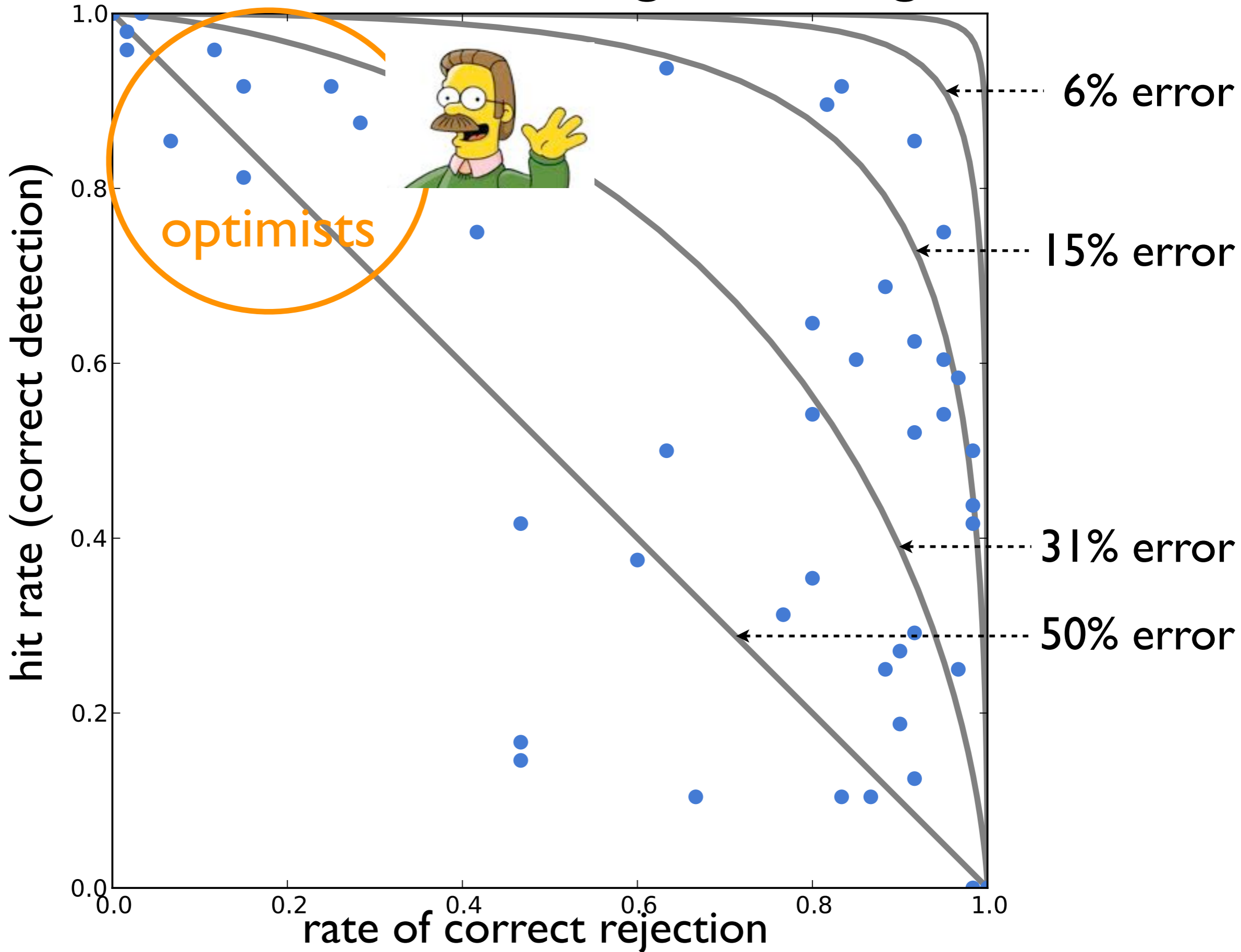

Task: Find the Indigo Bunting

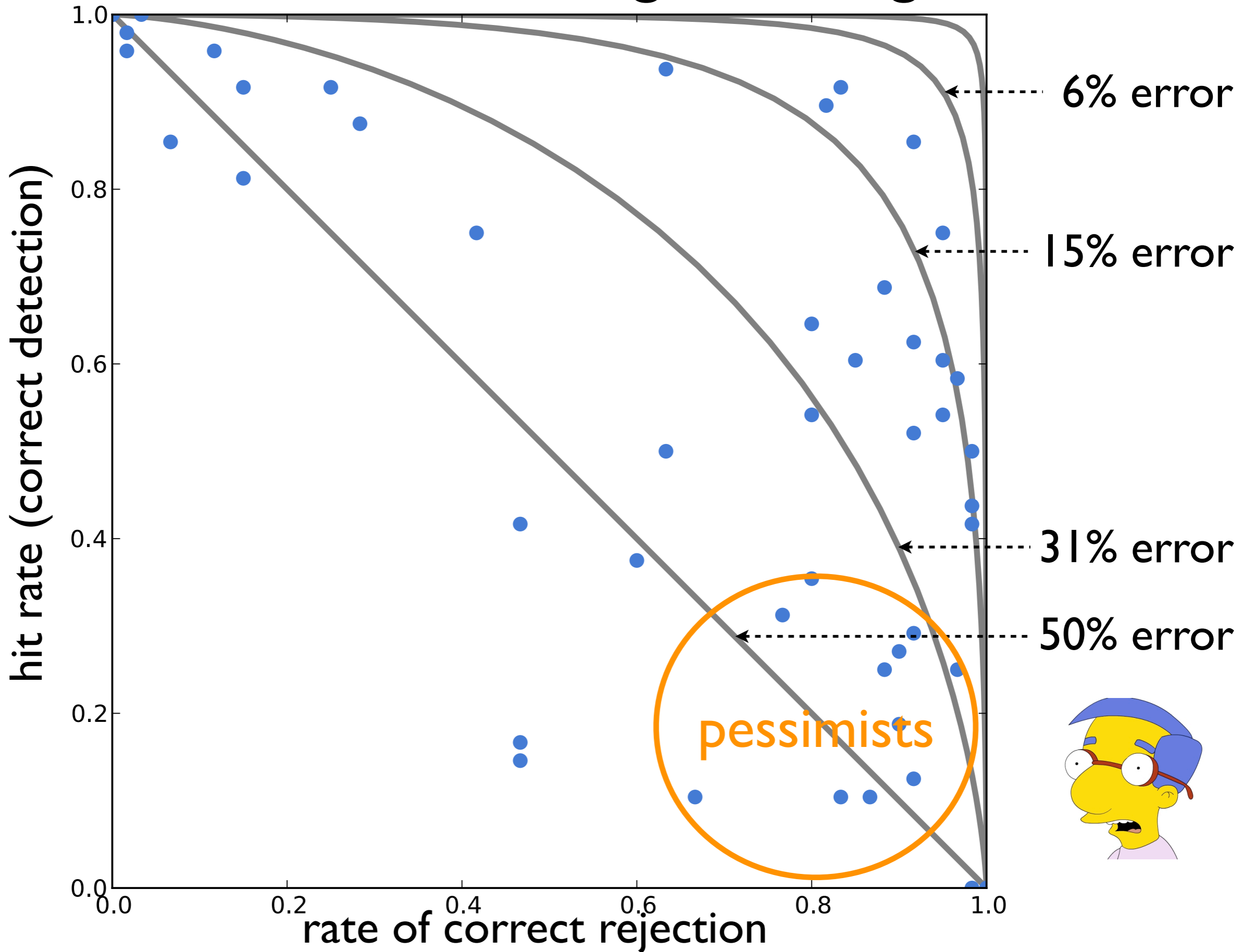

Task: Find the Indigo Bunting

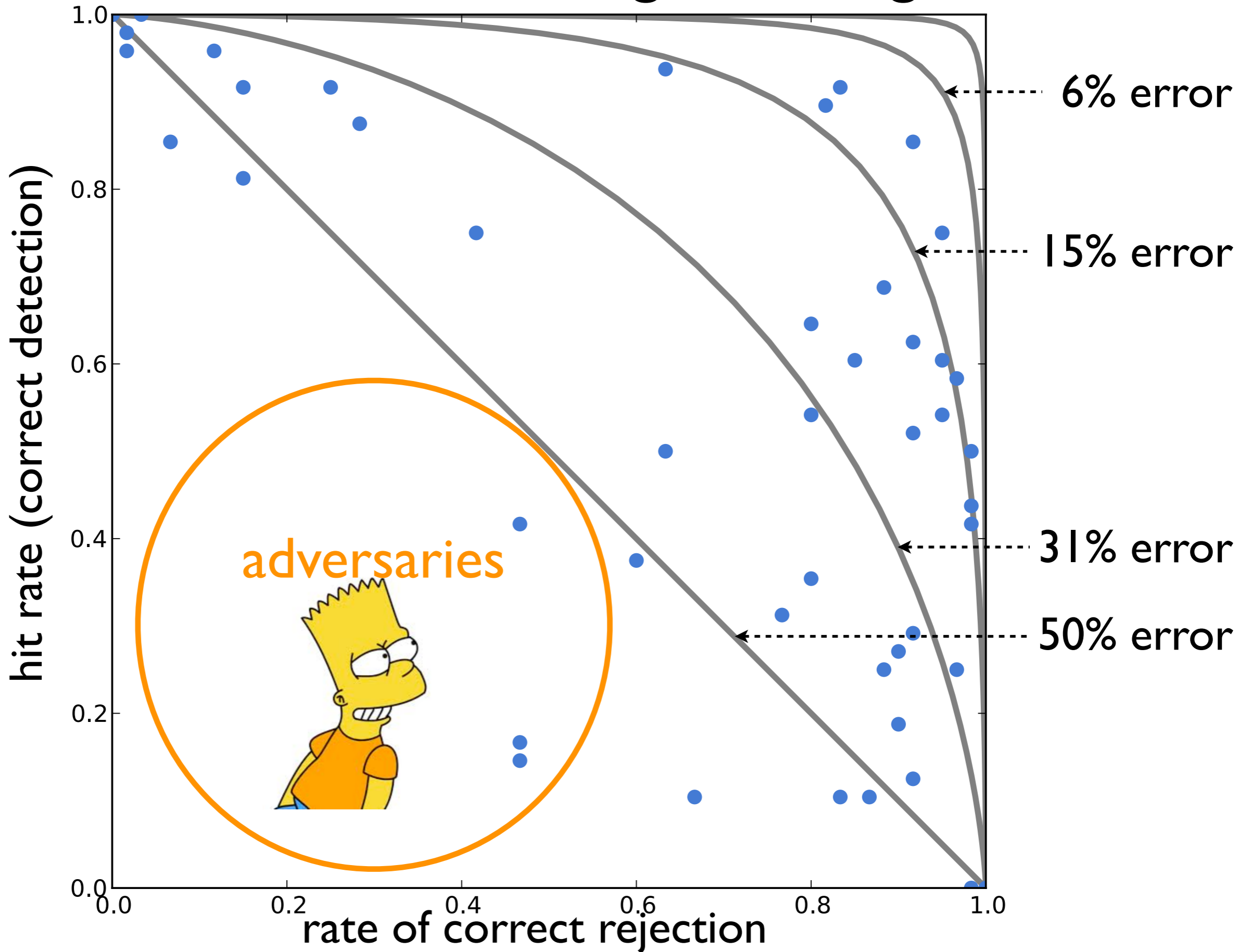

Image difficulty and annotator competence

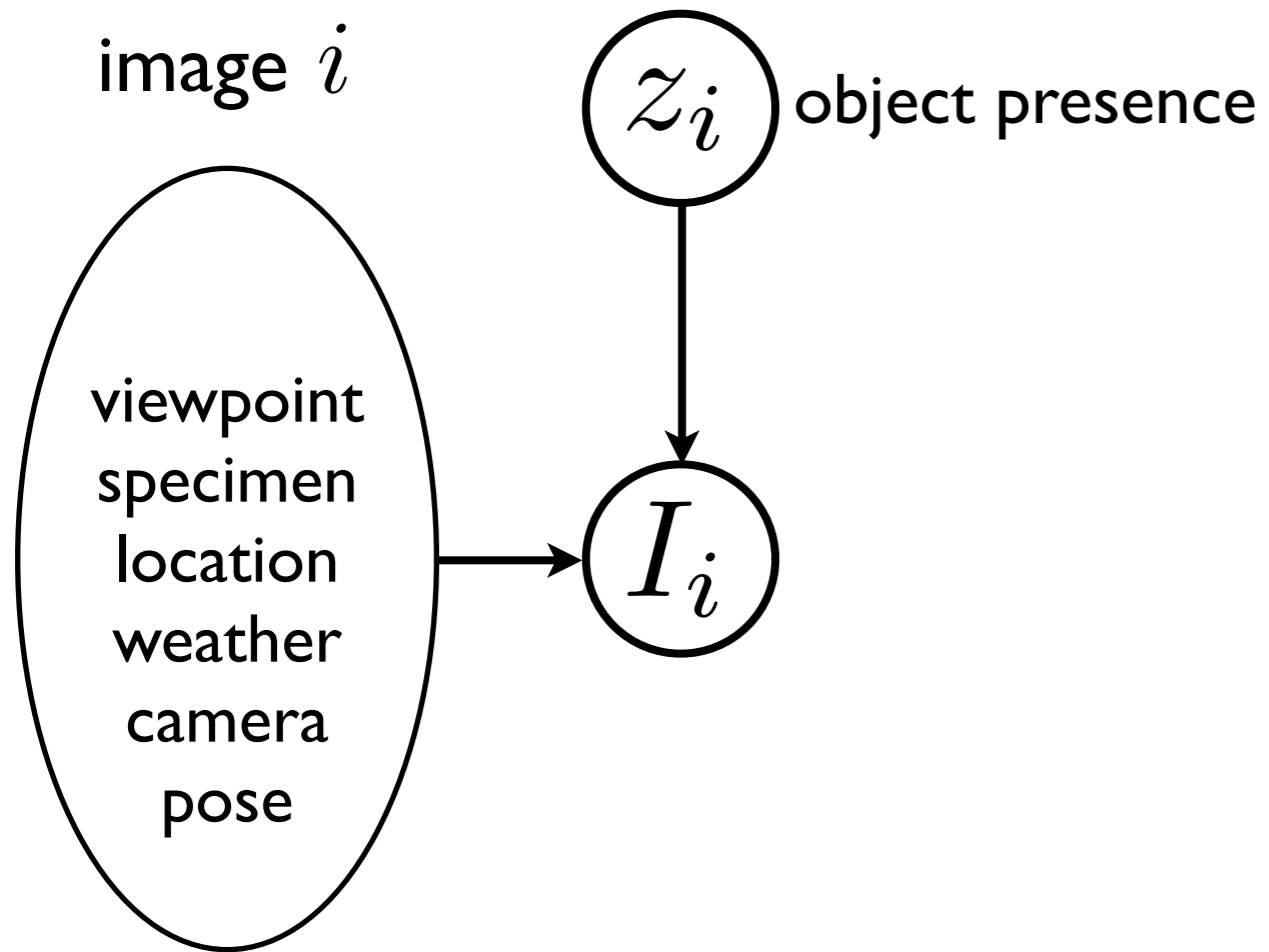

Image difficulty and annotator competence

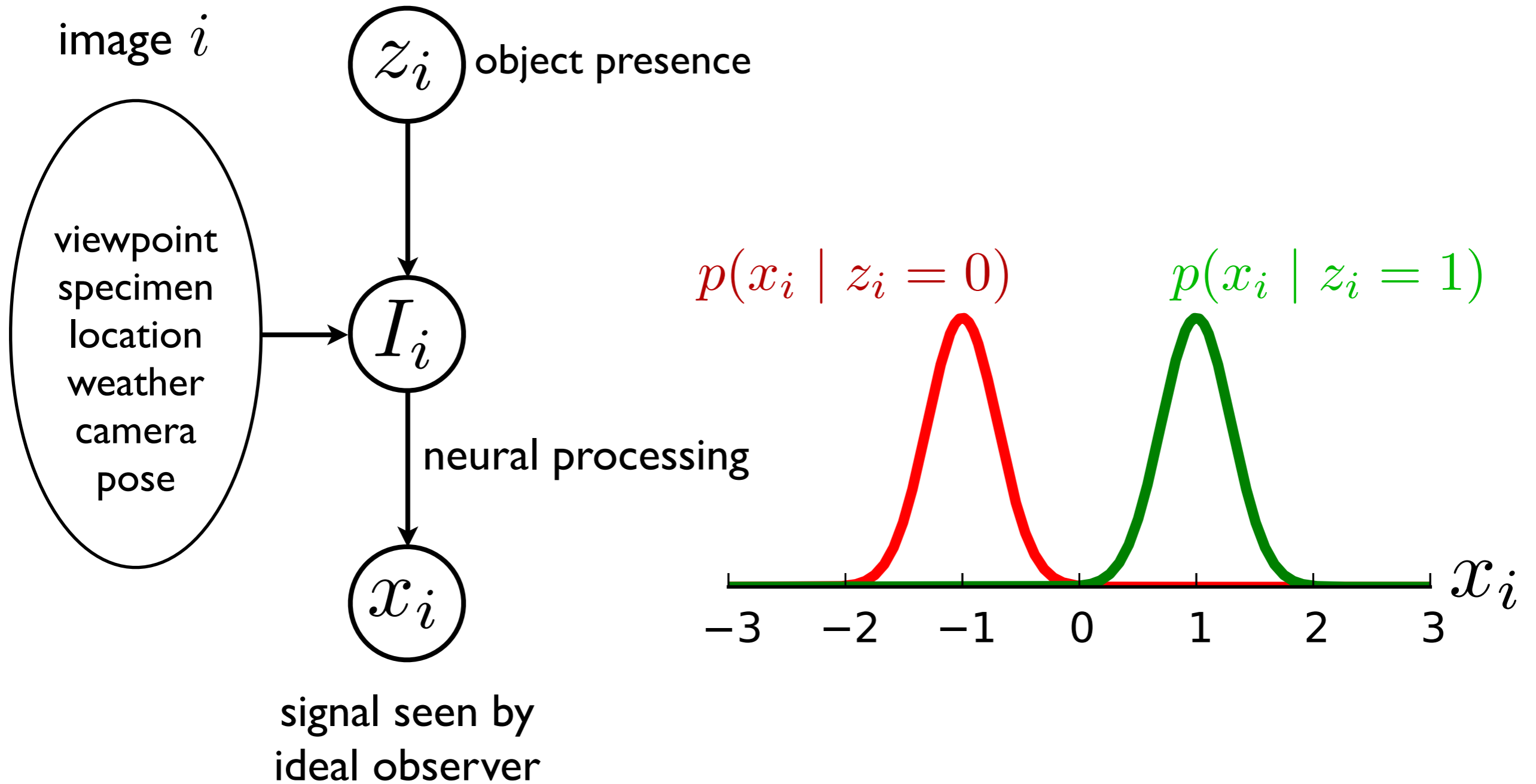
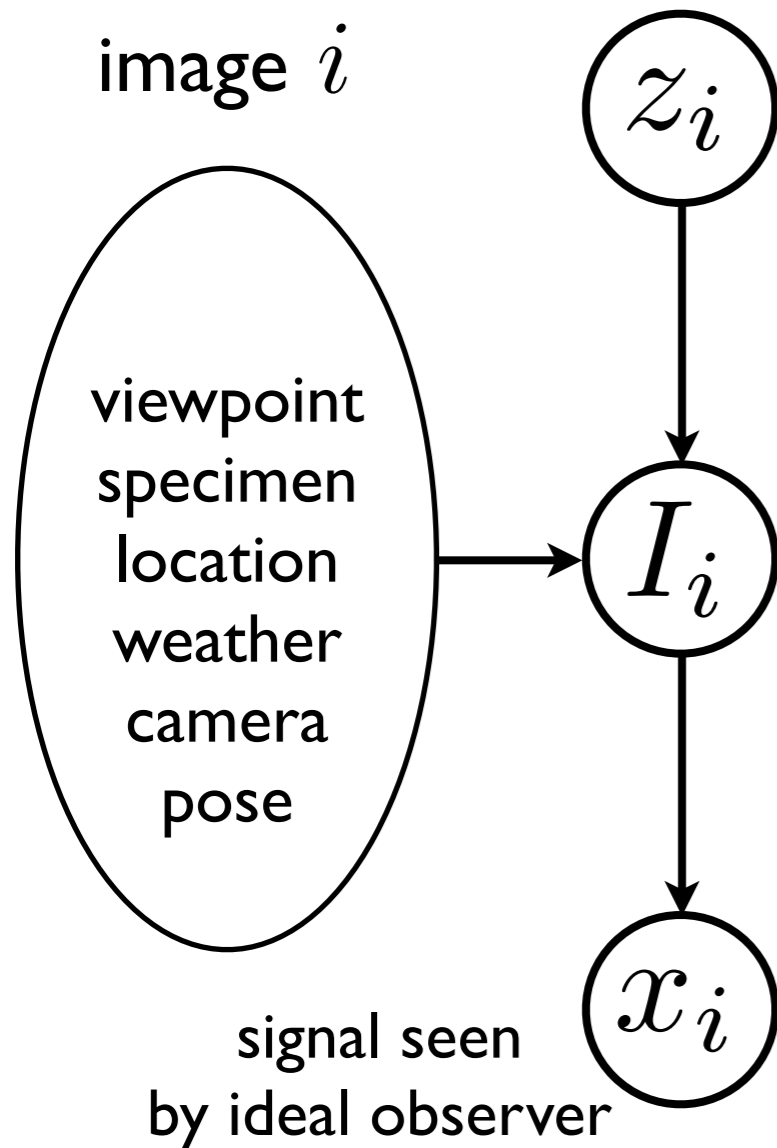

Image difficulty and annotator competence



$$p(x_i | z_i = 0)$$

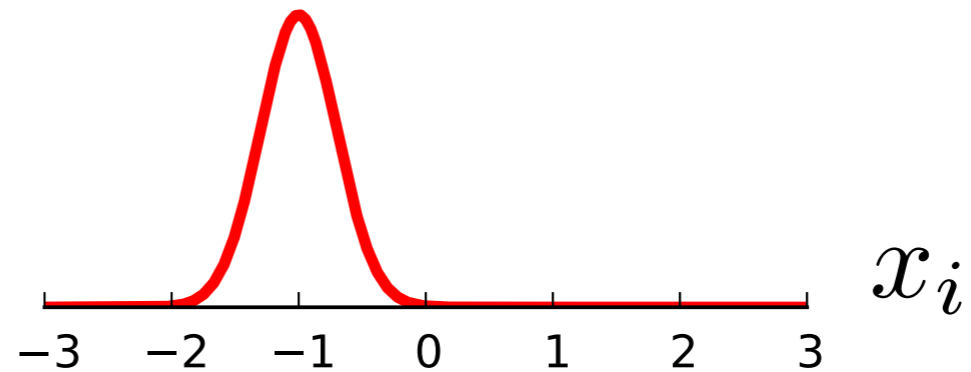
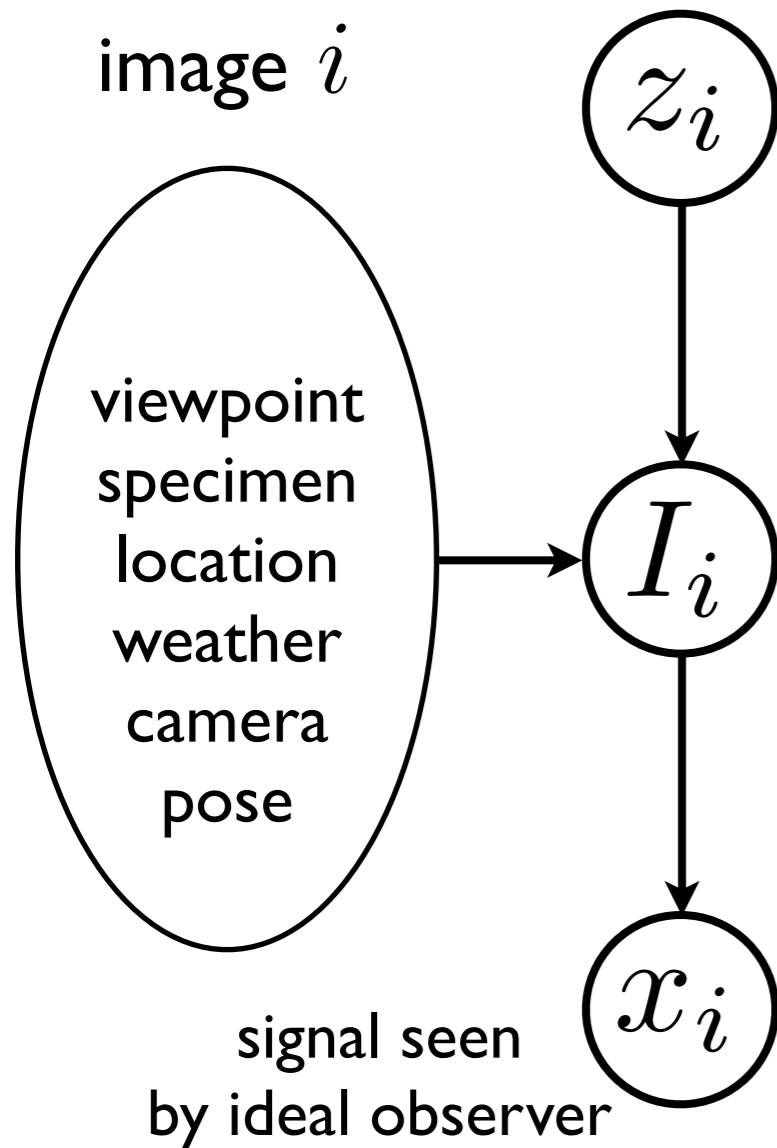

Image difficulty and annotator competence



$$p(x_i | z_i = 0)$$

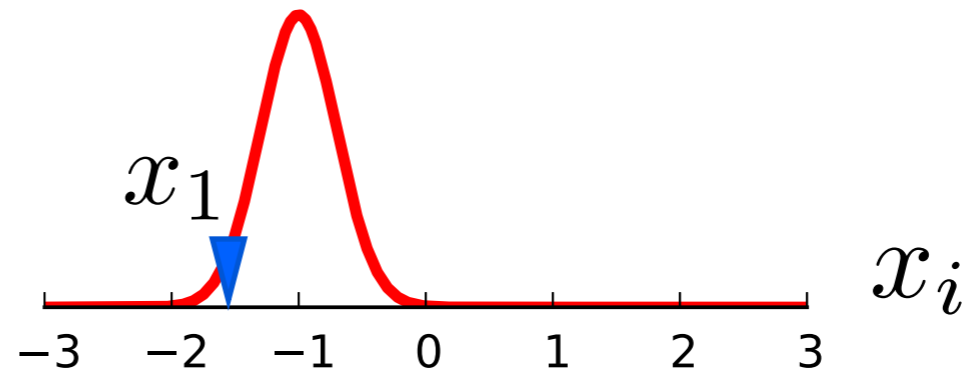
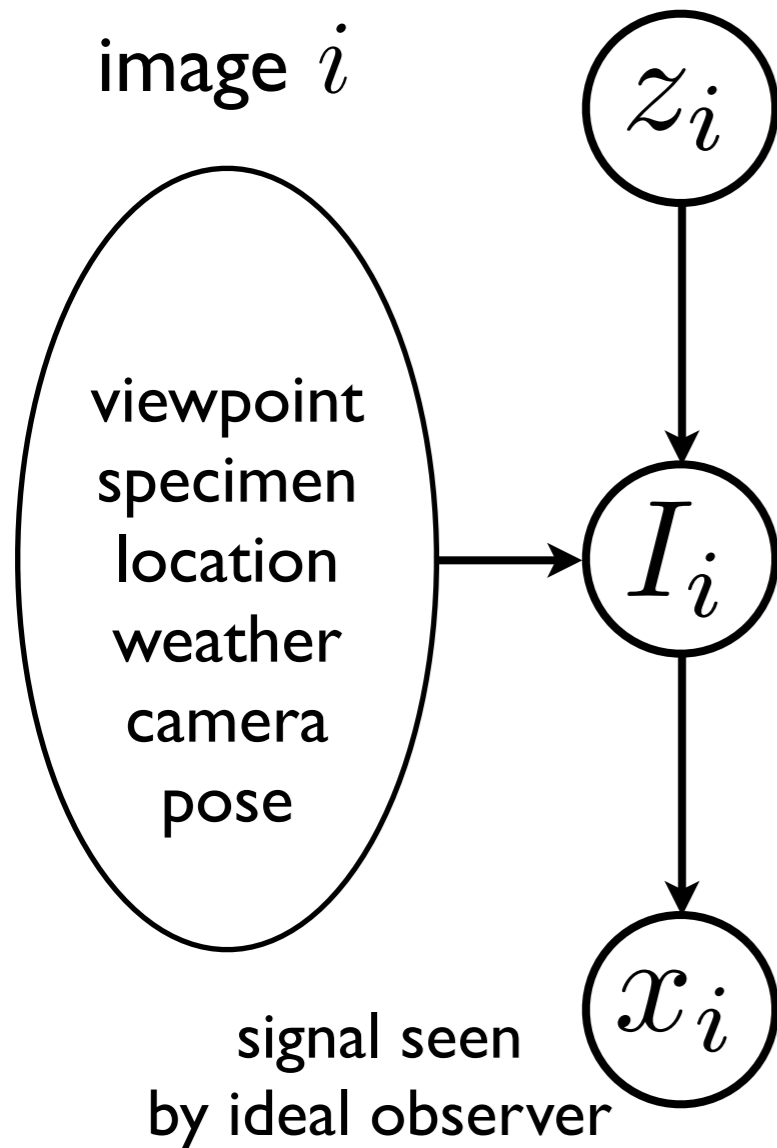

Image difficulty and annotator competence



$$p(x_i | z_i = 0)$$

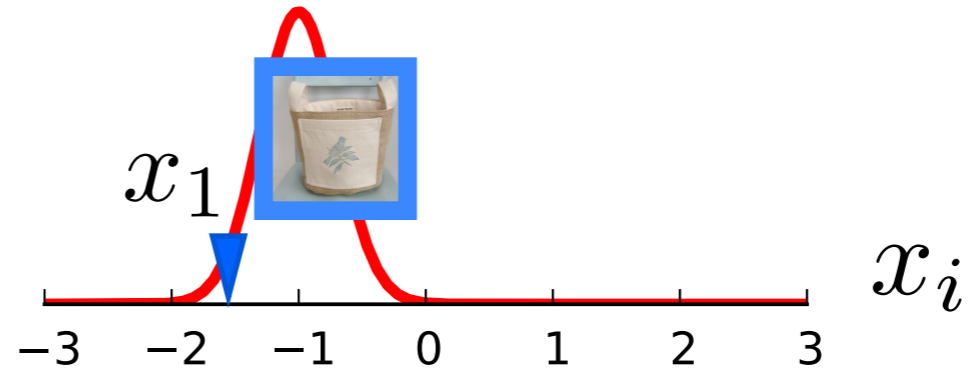
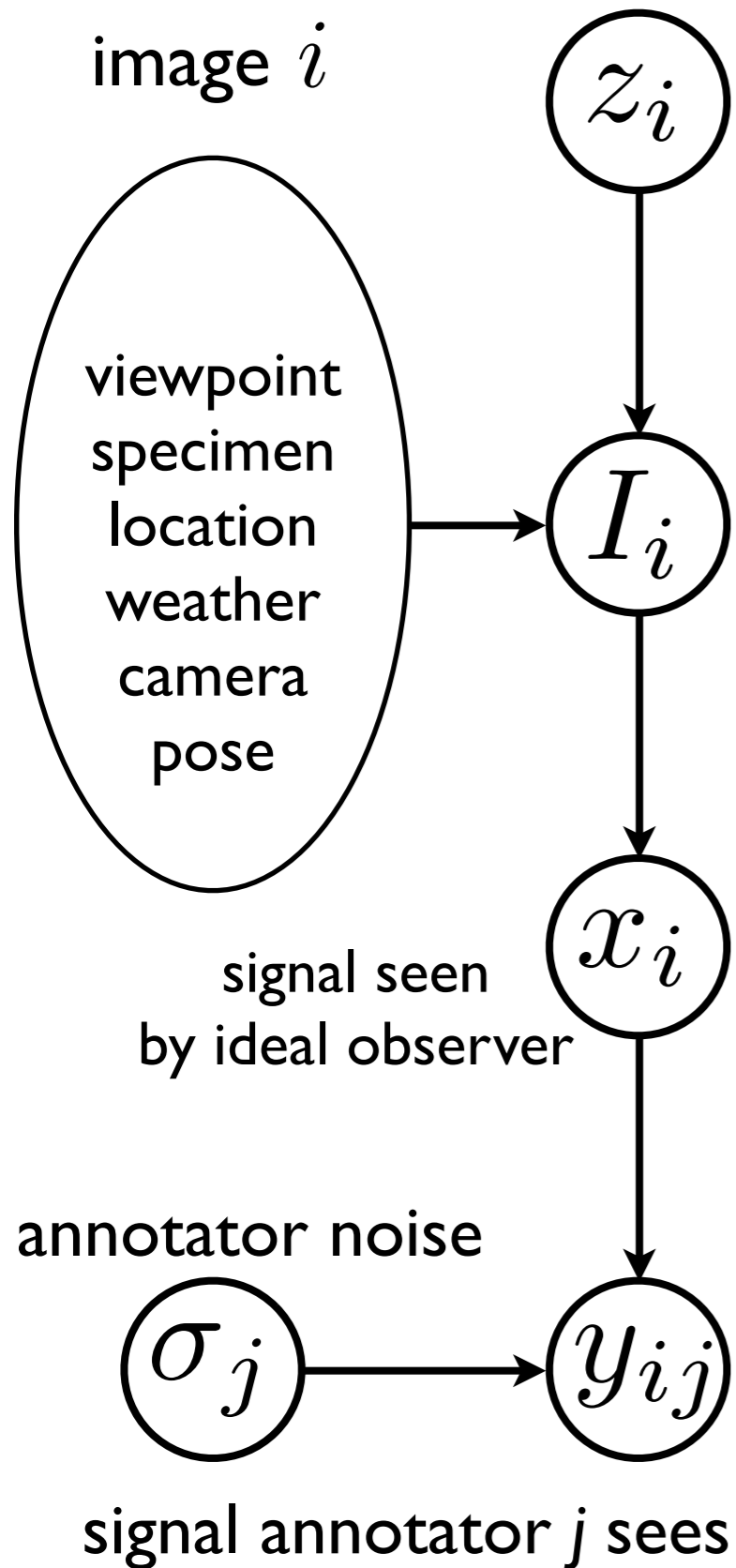

Image difficulty and annotator competence



$$p(x_i | z_i = 0)$$

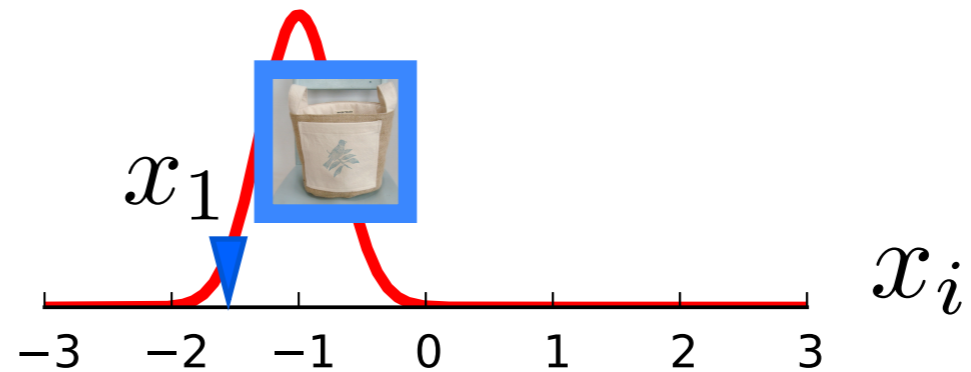
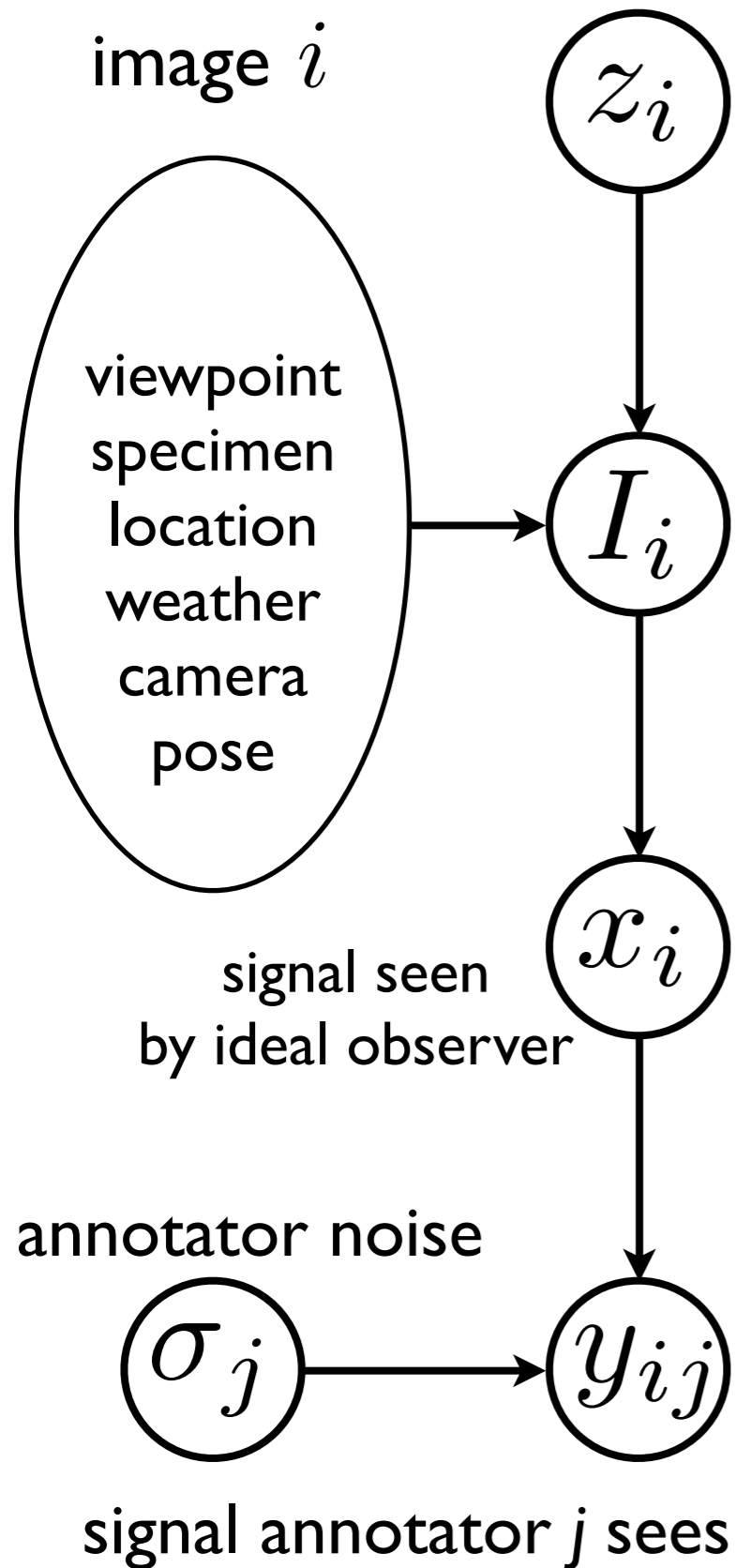
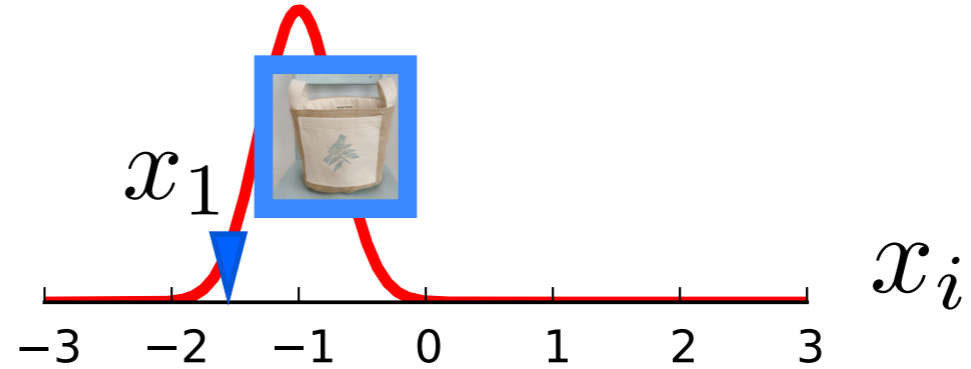

Image difficulty and annotator competence



$$p(x_i | z_i = 0)$$



$$\sigma_1 = 0.2$$

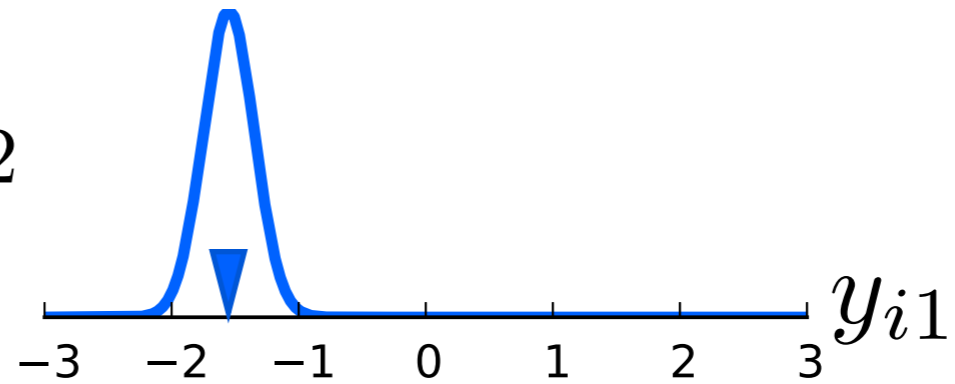
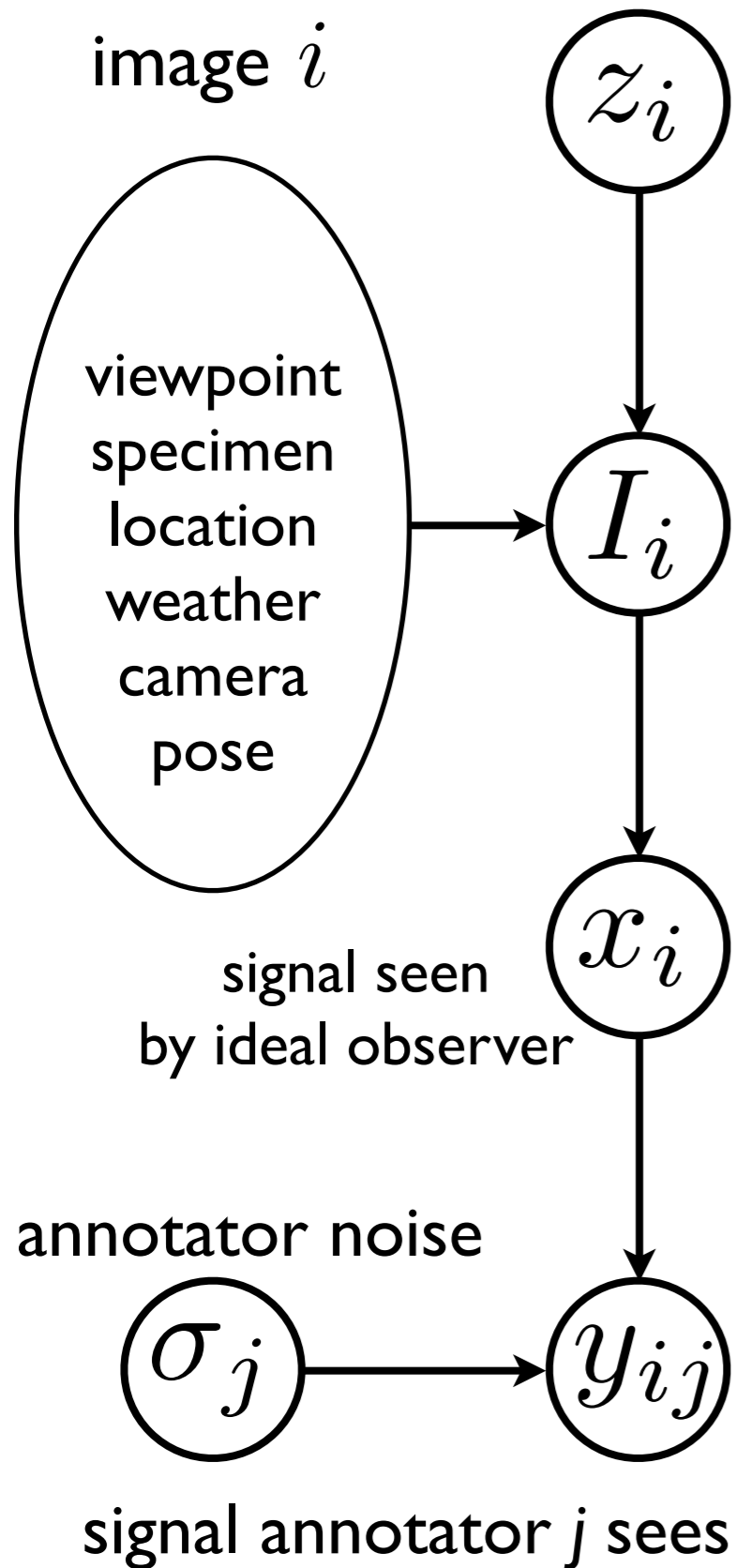
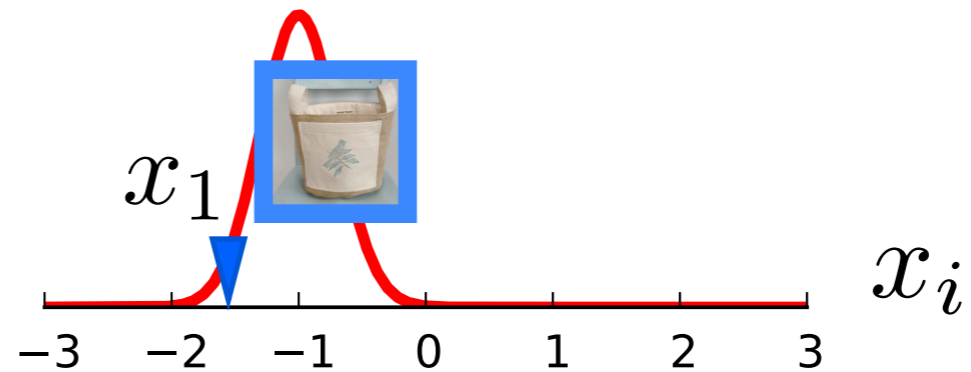

Image difficulty and annotator competence



$$p(x_i | z_i = 0)$$



$$\sigma_1 = 0.2$$

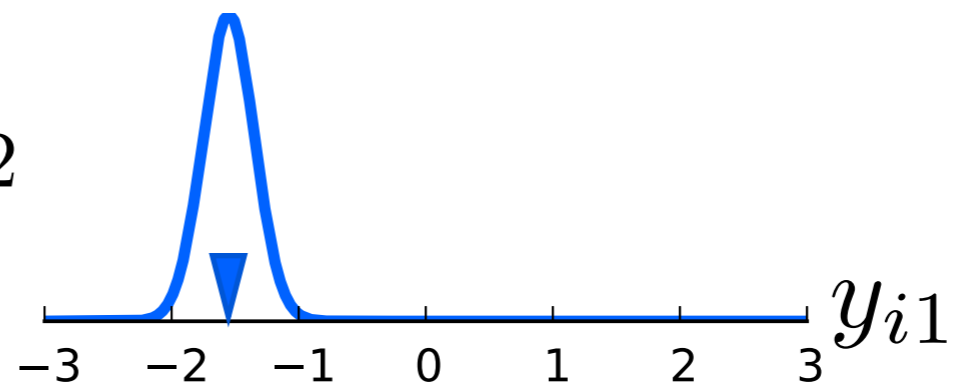

$$\sigma_2 = 0.5$$

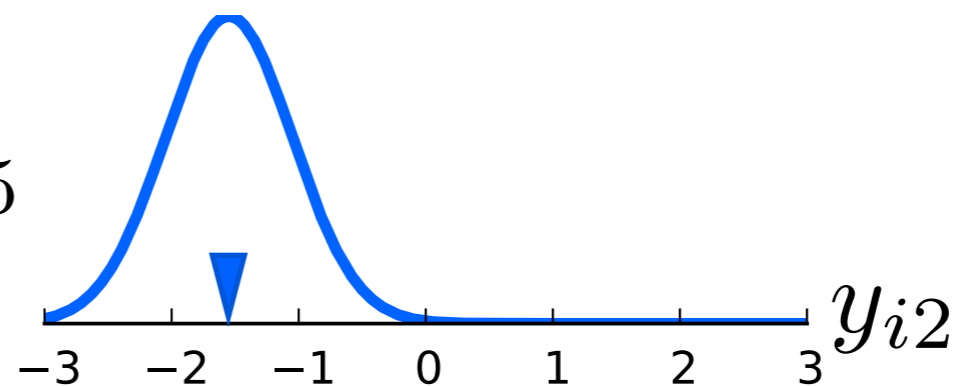
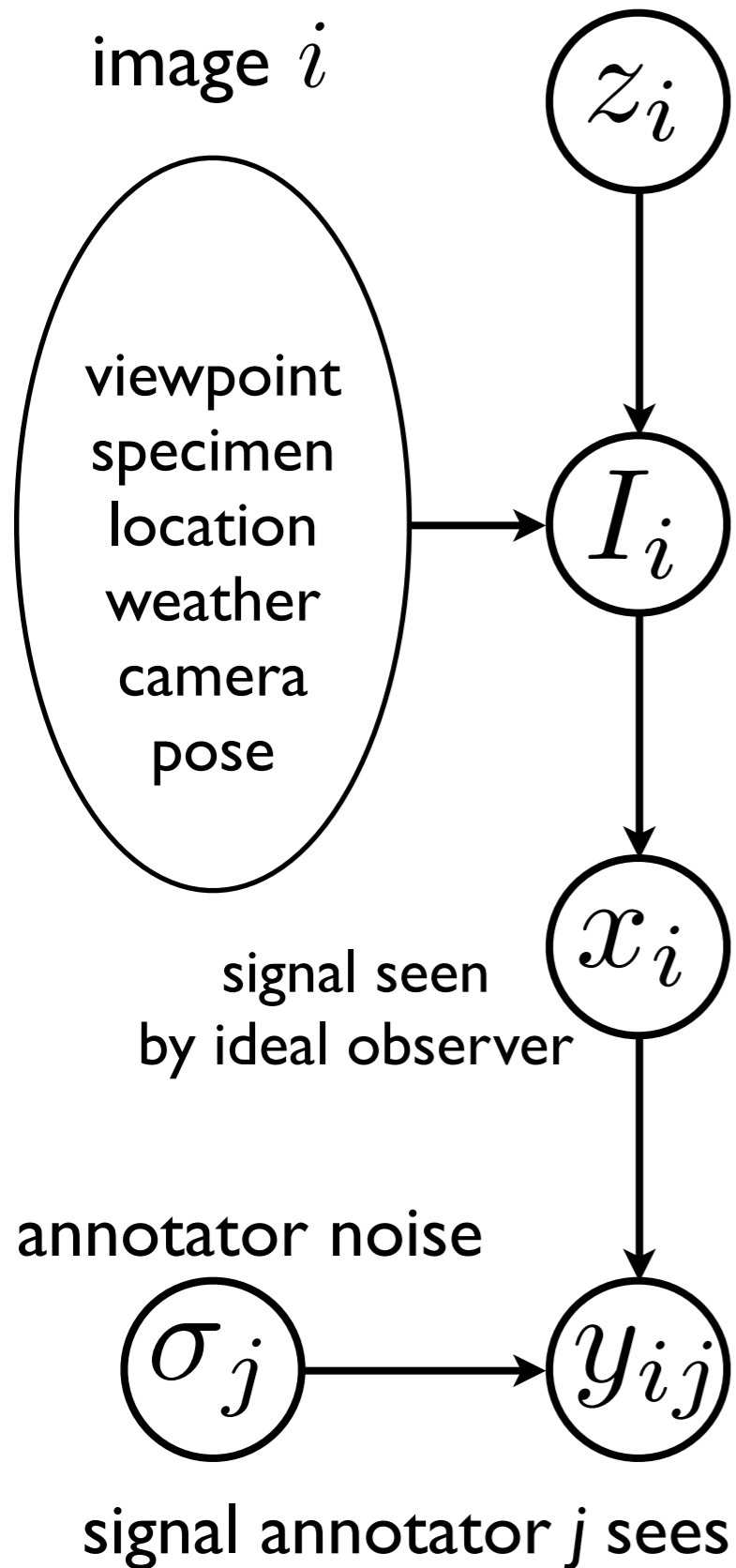

Image difficulty and annotator competence



$$p(x_i | z_i = 0)$$

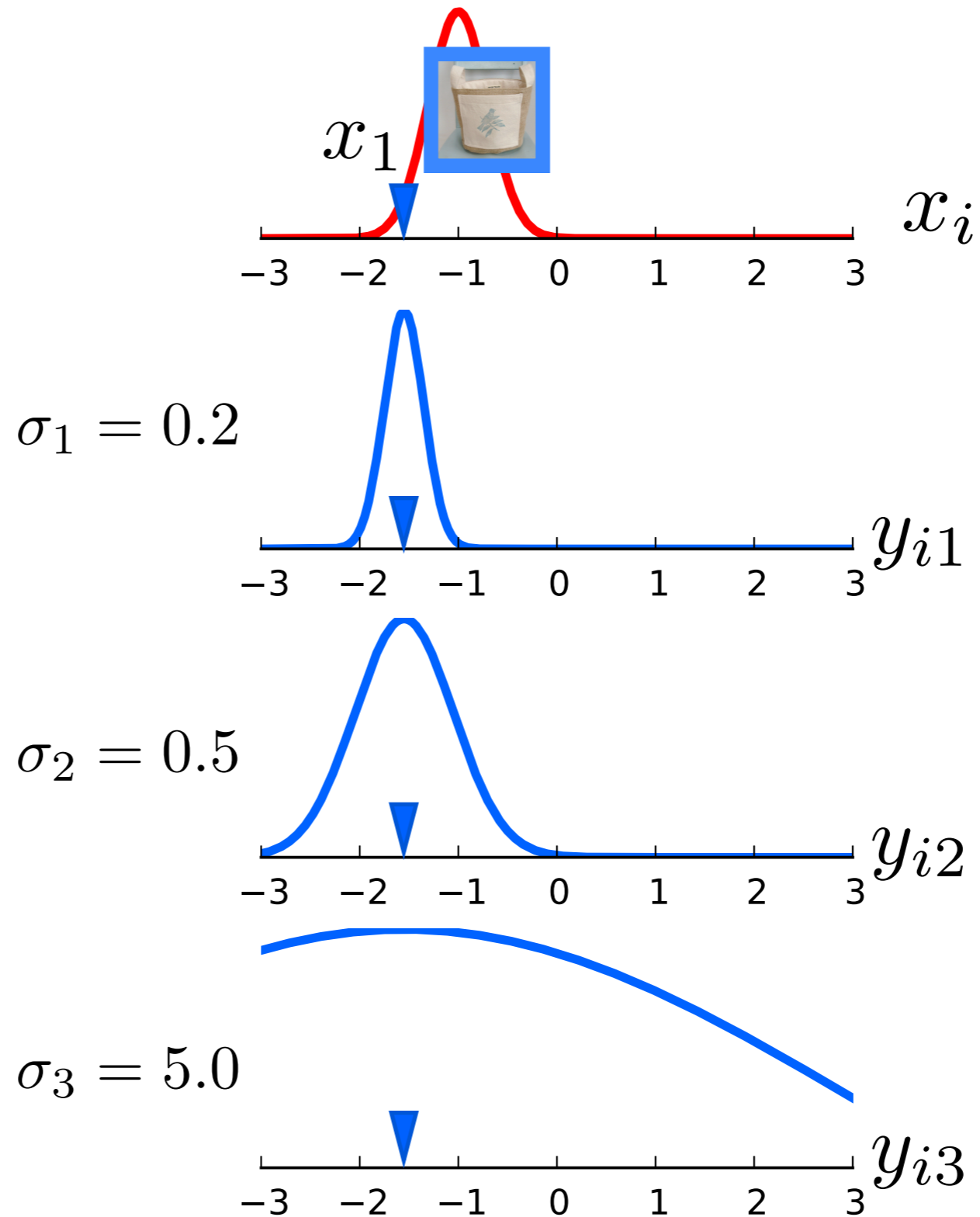
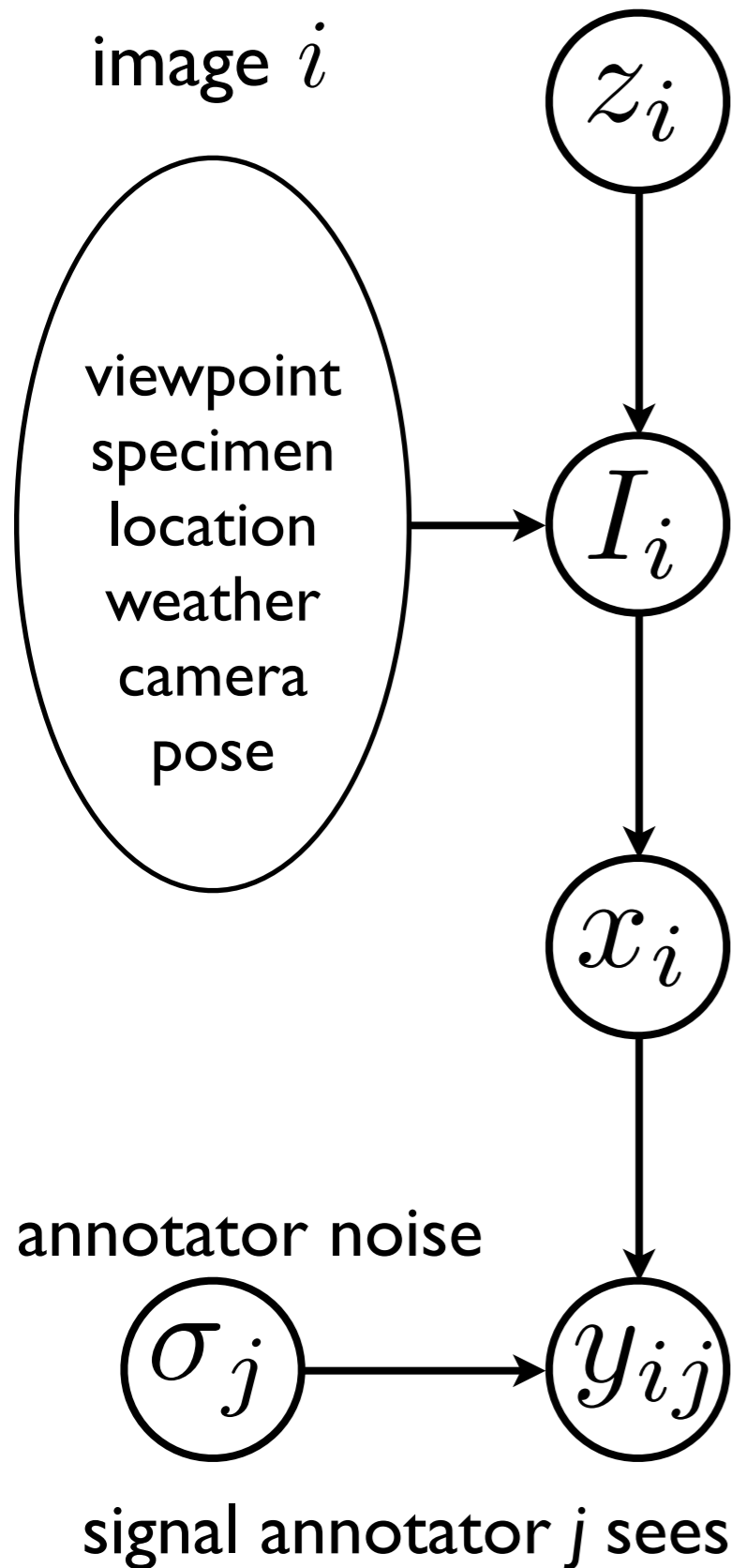

Image difficulty and annotator competence



$$p(x_i | z_i = 1)$$

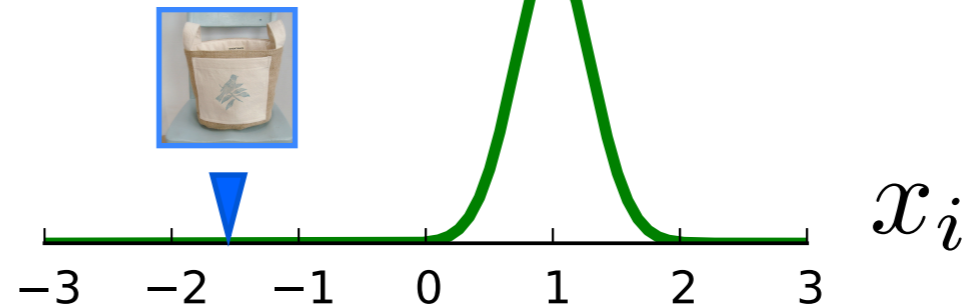
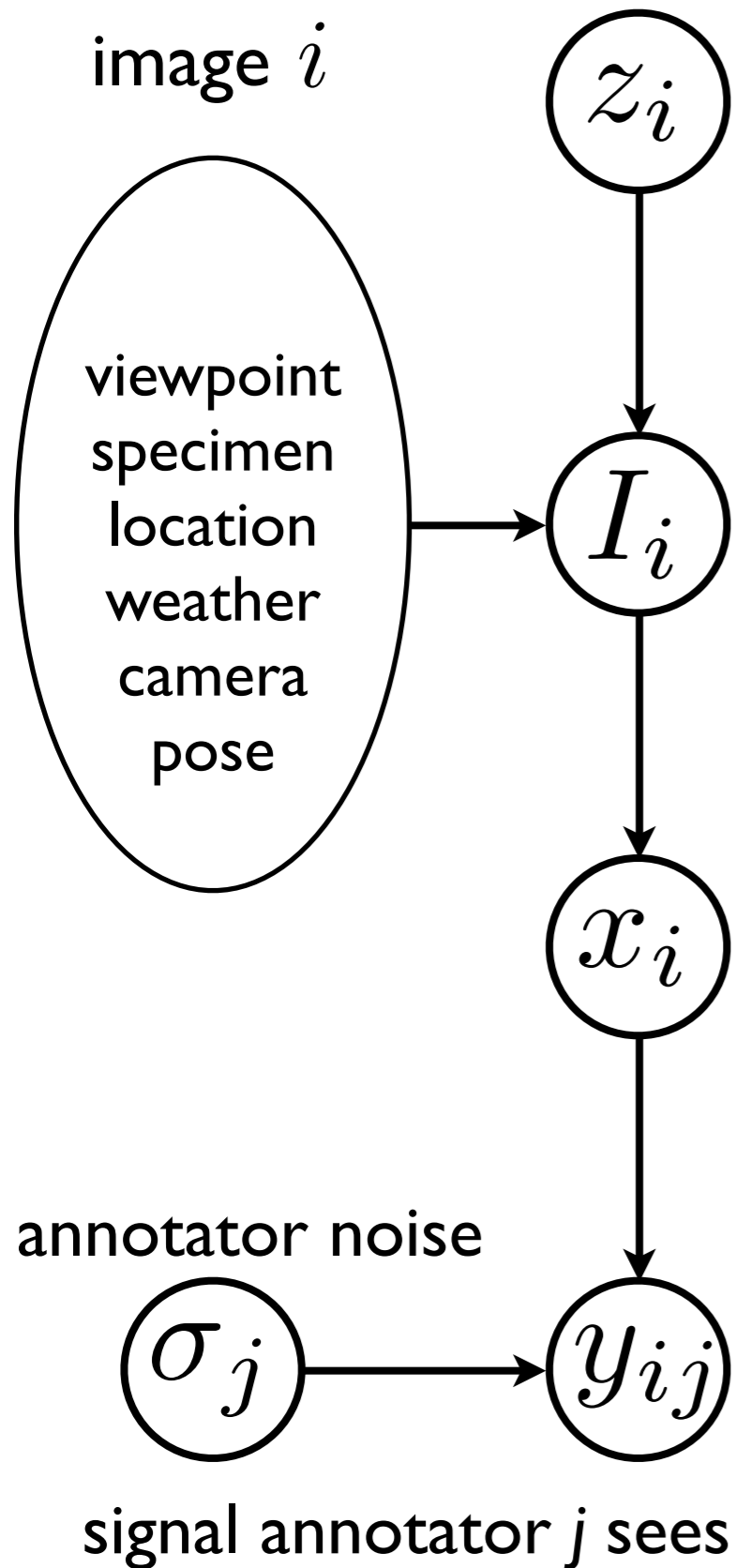

Image difficulty and annotator competence



$$p(x_i | z_i = 1)$$

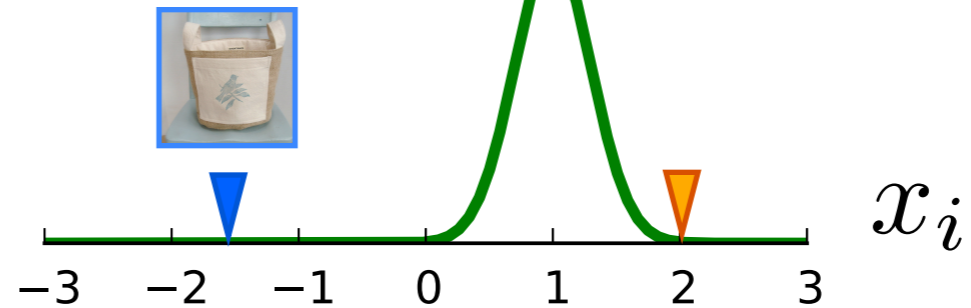
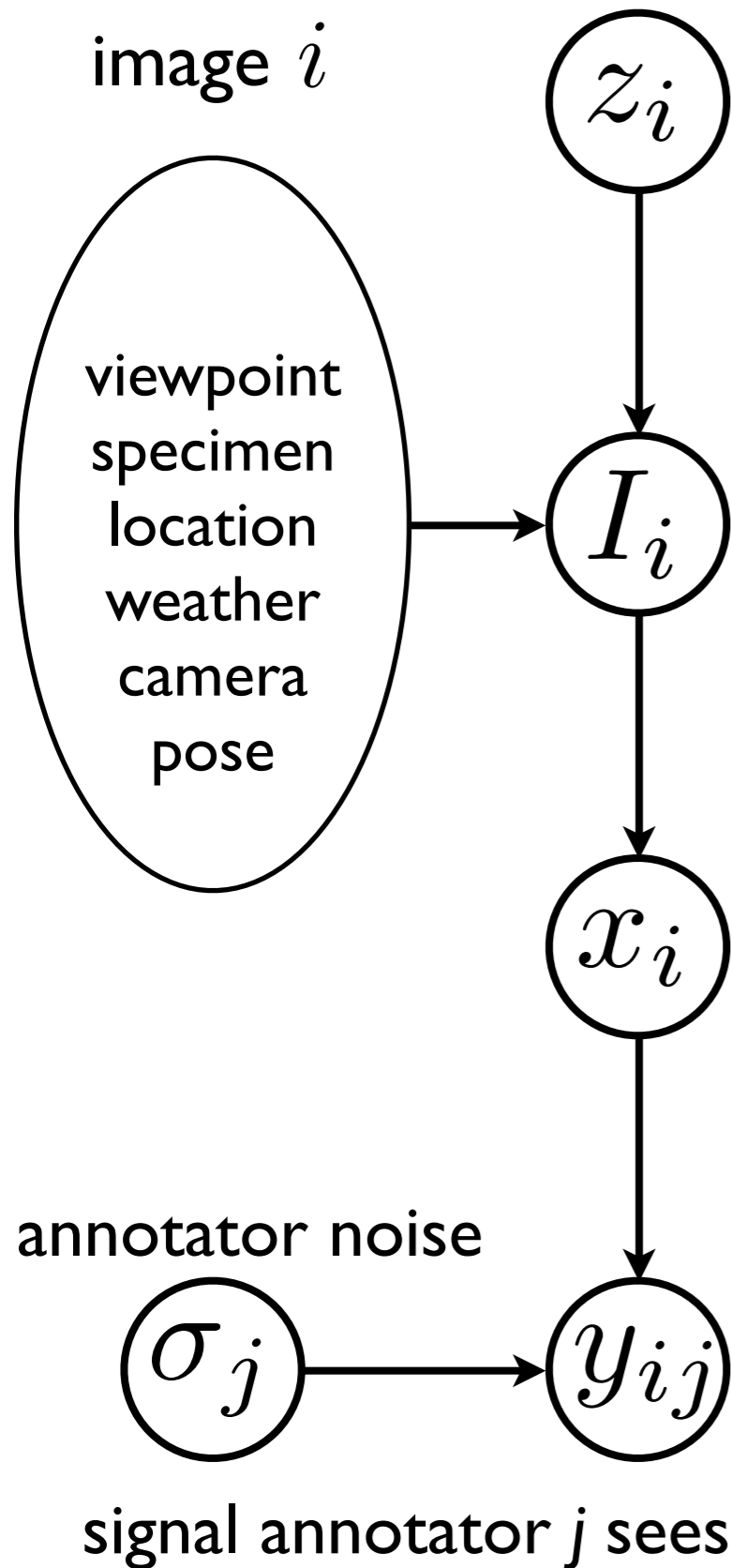

Image difficulty and annotator competence



$$p(x_i | z_i = 1)$$

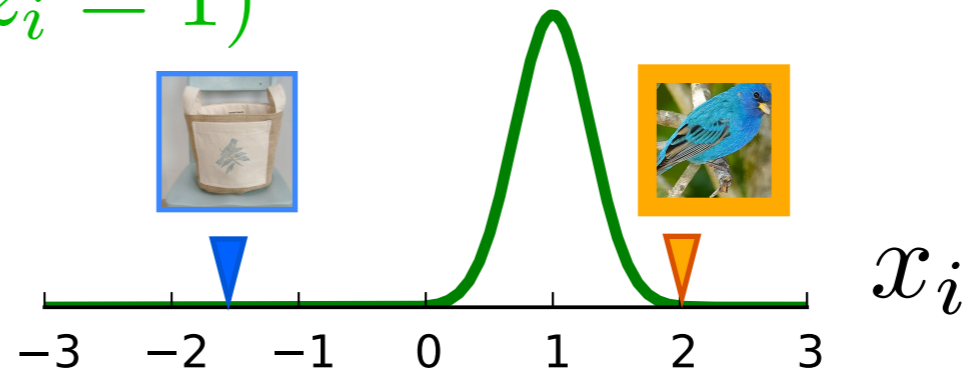
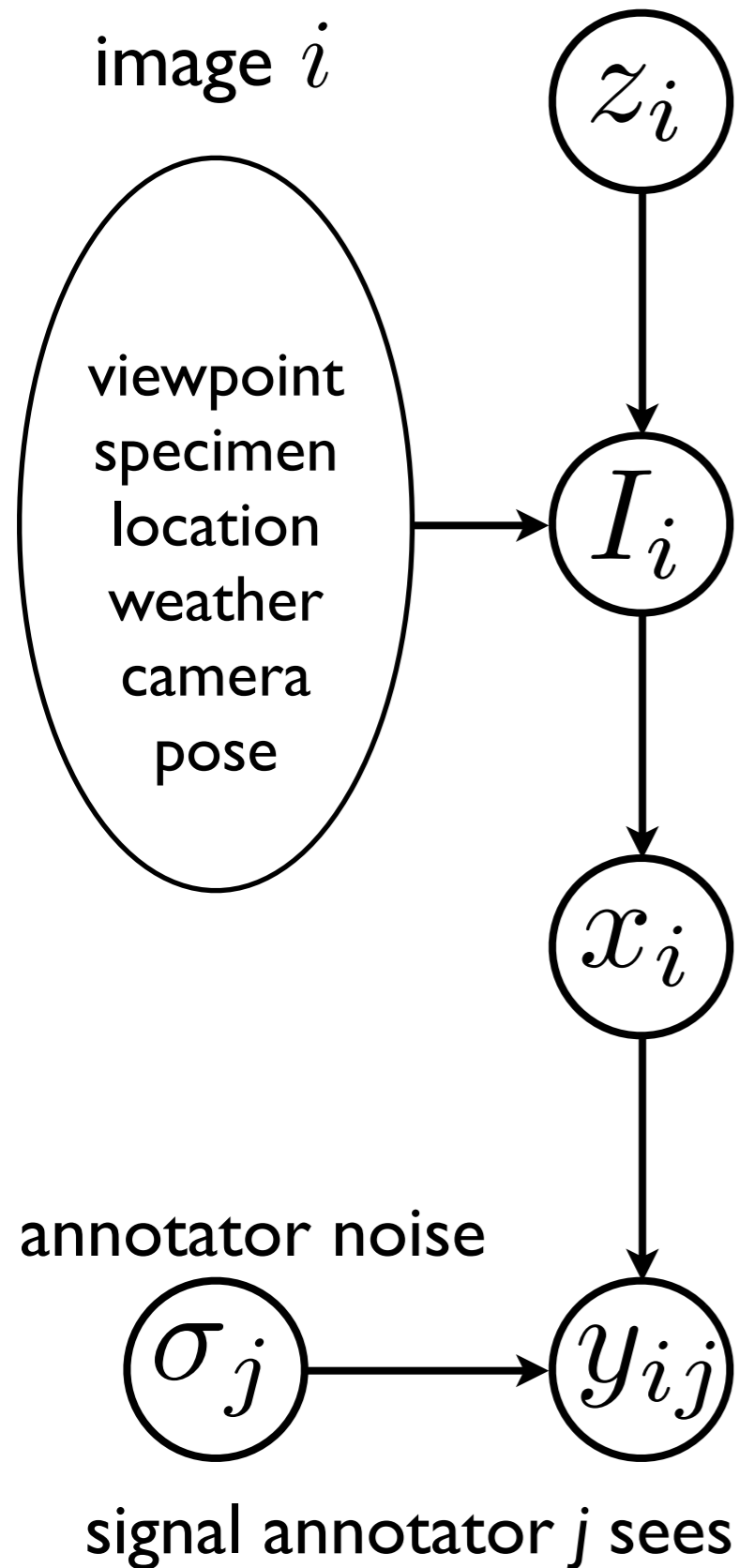

Image difficulty and annotator competence



$$p(x_i | z_i = 1)$$

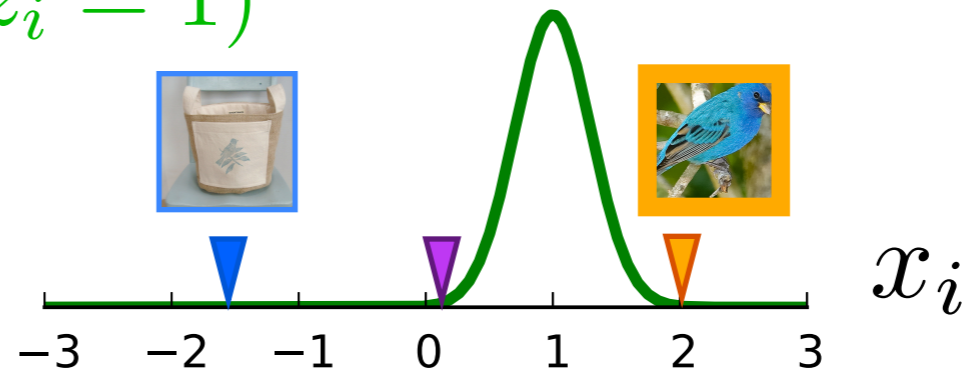
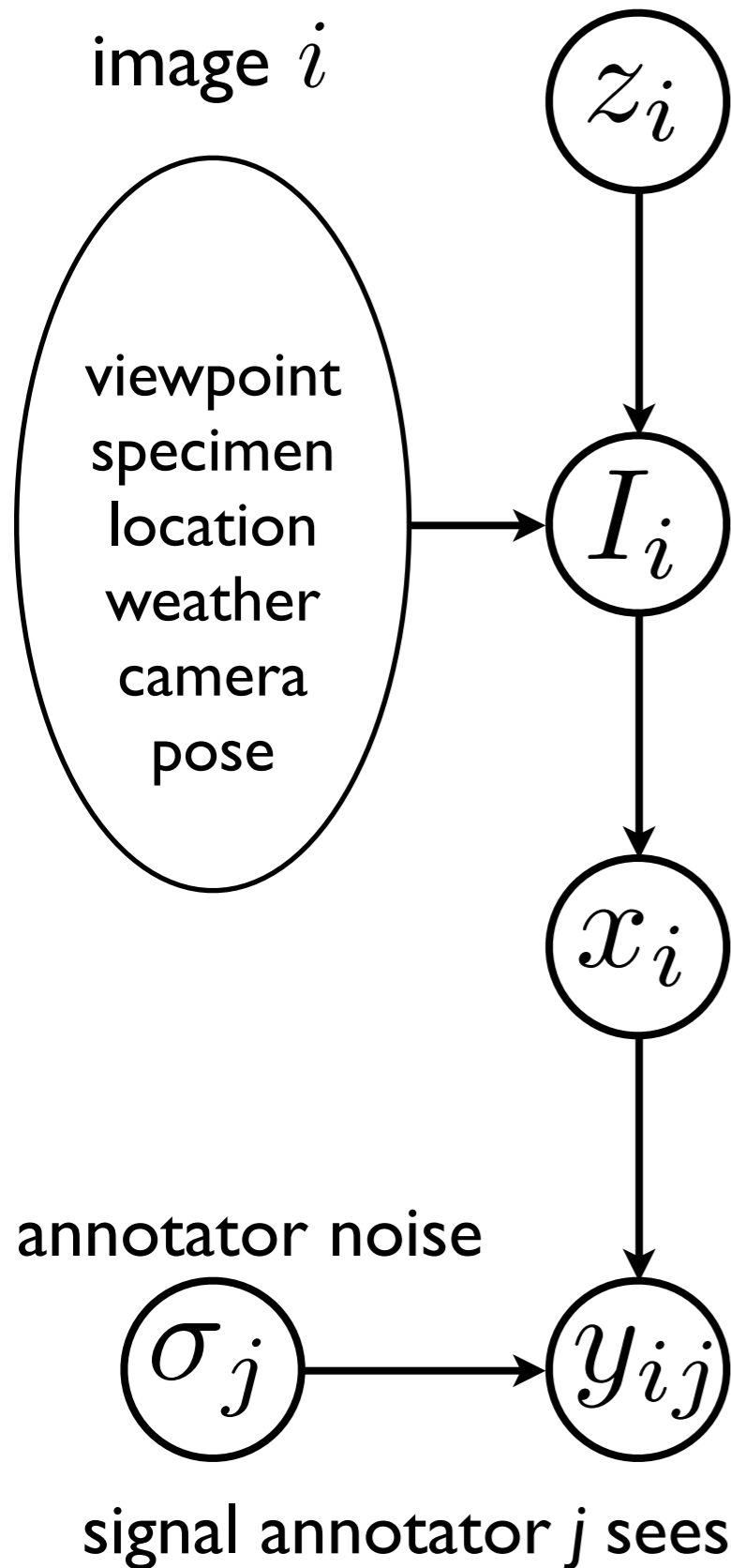

Image difficulty and annotator competence



$$p(x_i | z_i = 1)$$

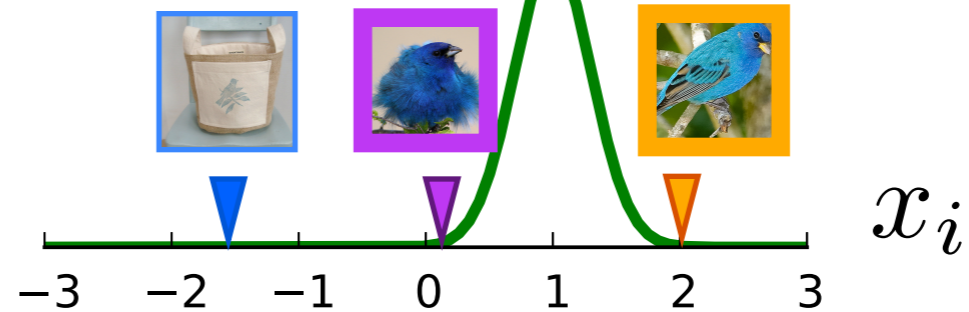
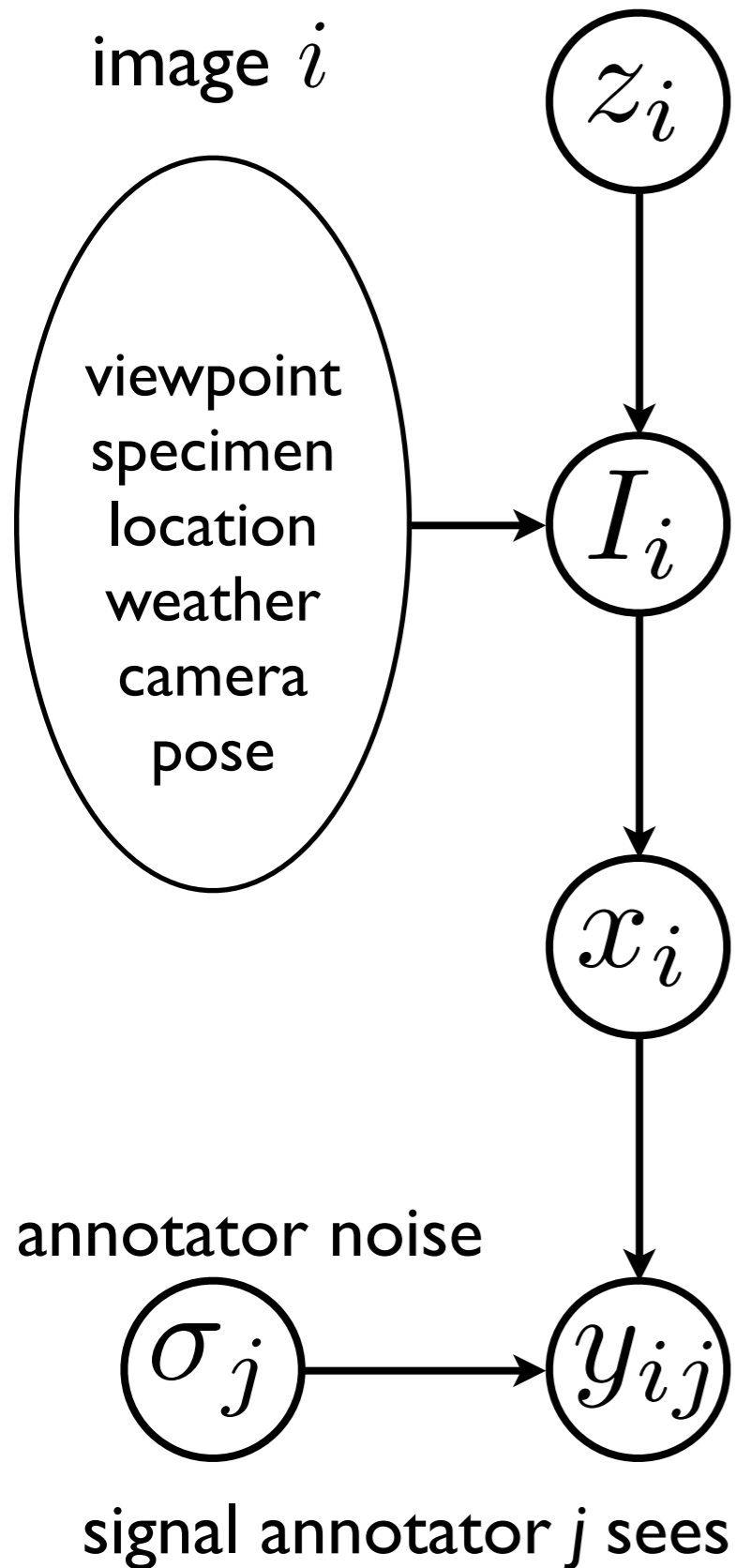
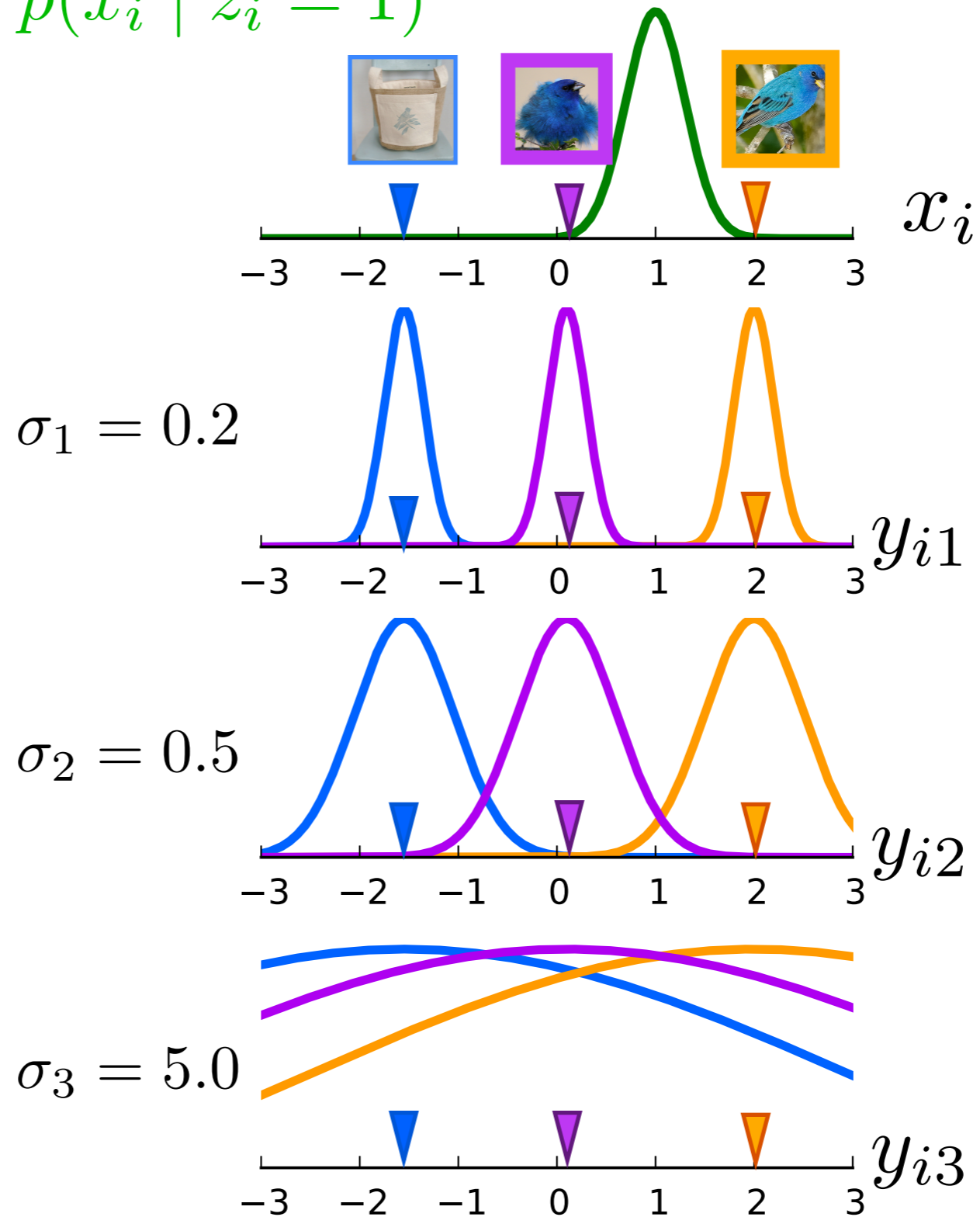

Image difficulty and annotator competence



$$p(x_i | z_i = 1)$$



Optimists and pessimists: τ_j

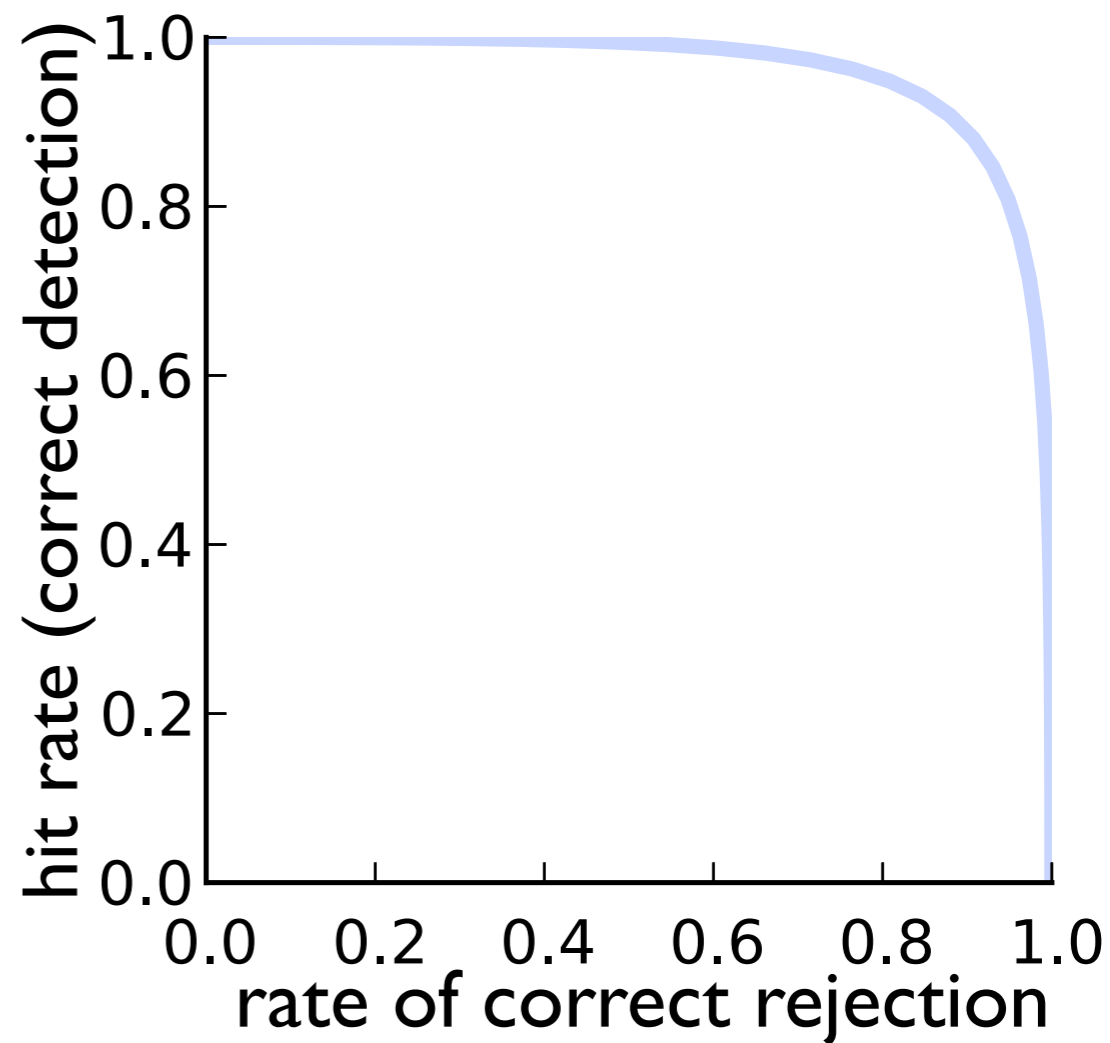
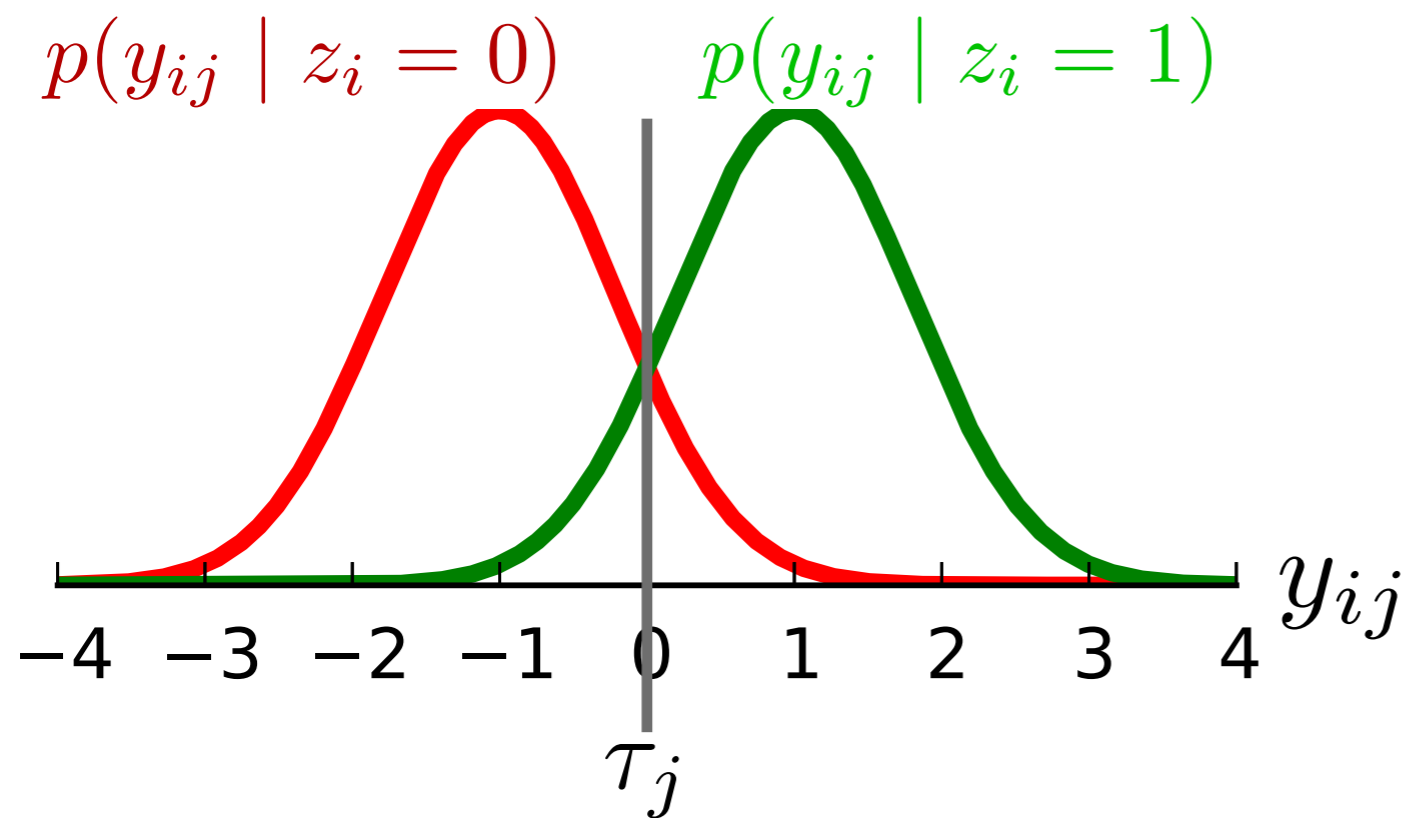

Optimists and pessimists: τ_j

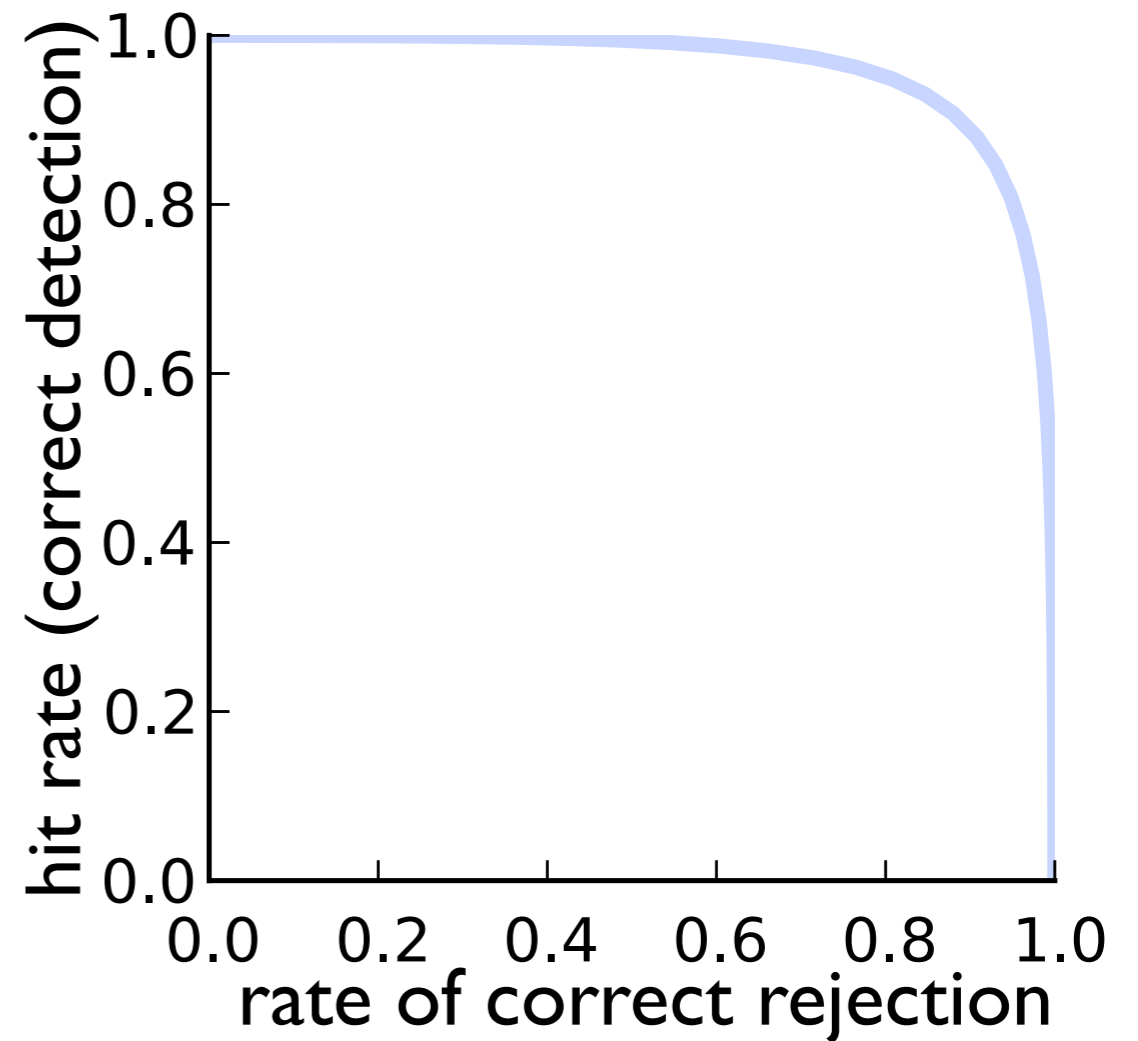
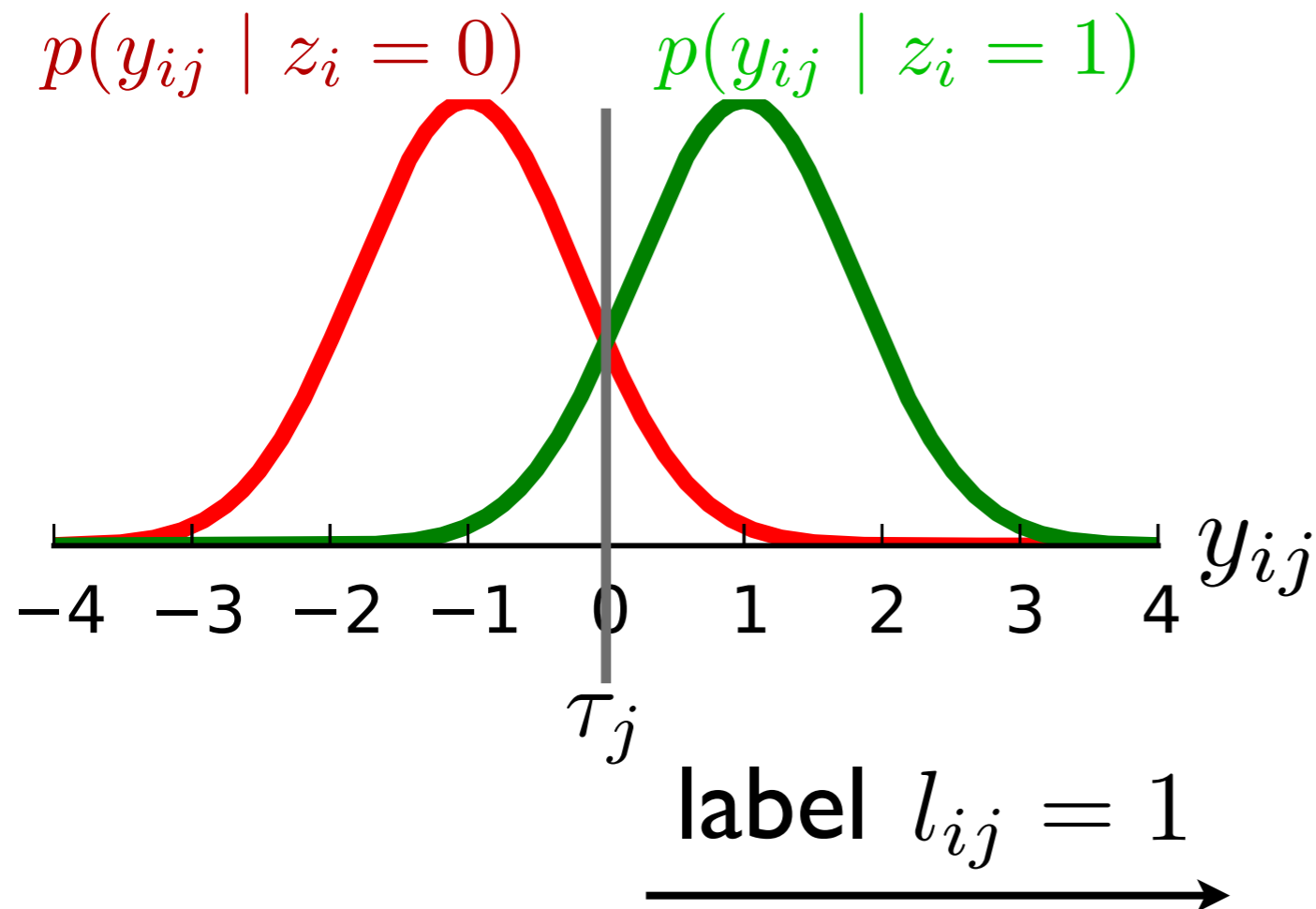

Optimists and pessimists: τ_j

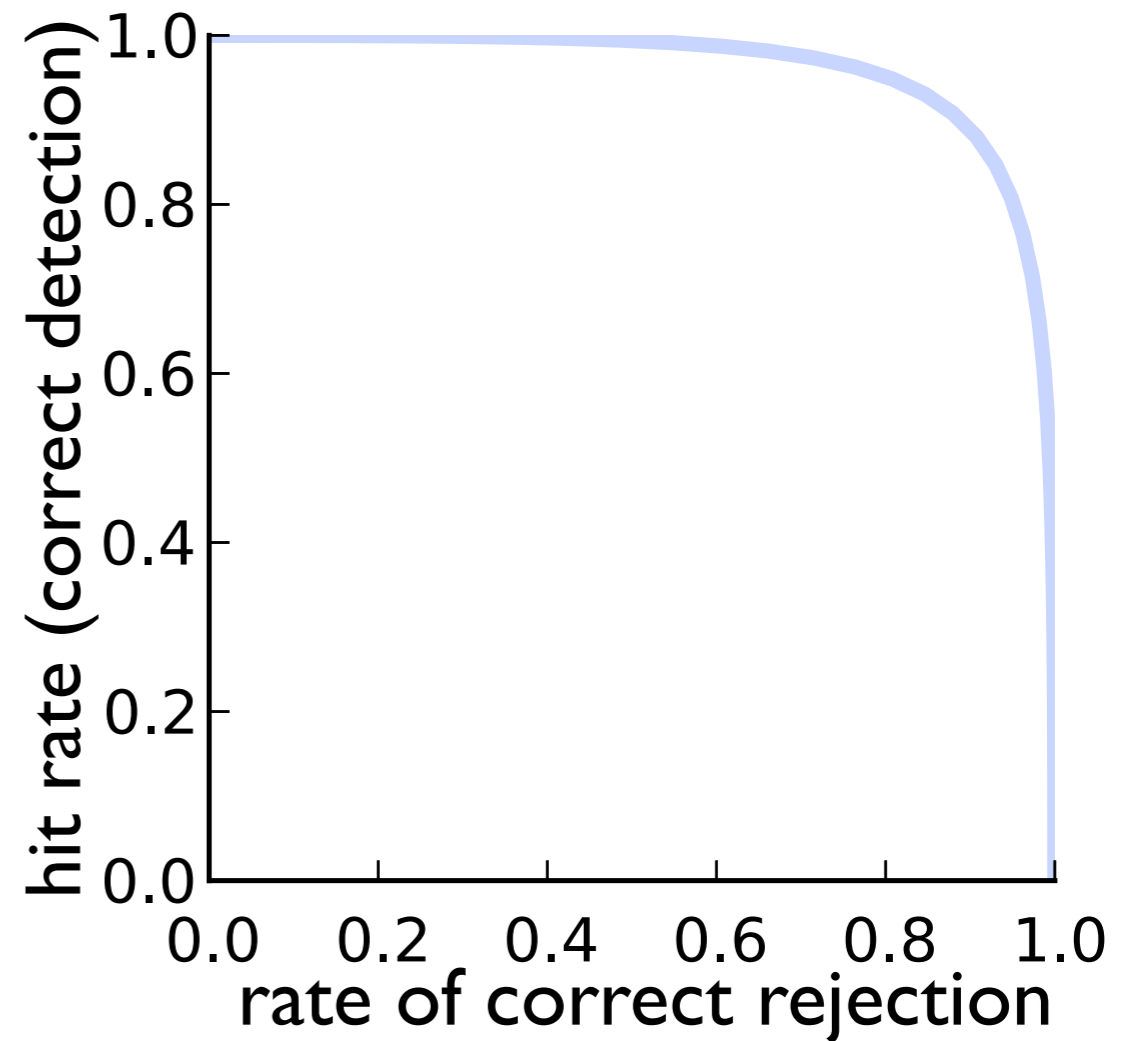
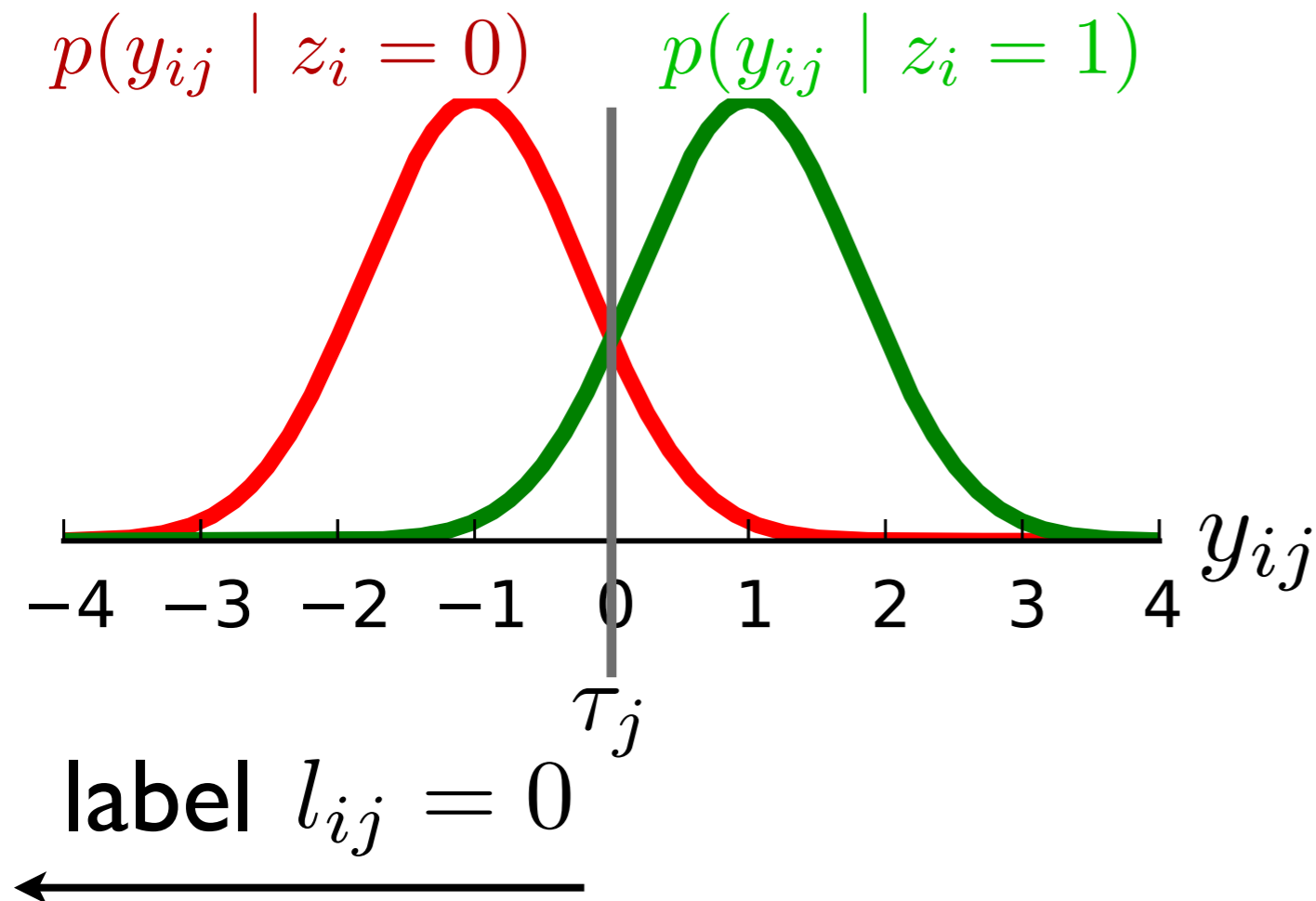

Optimists and pessimists: τ_j

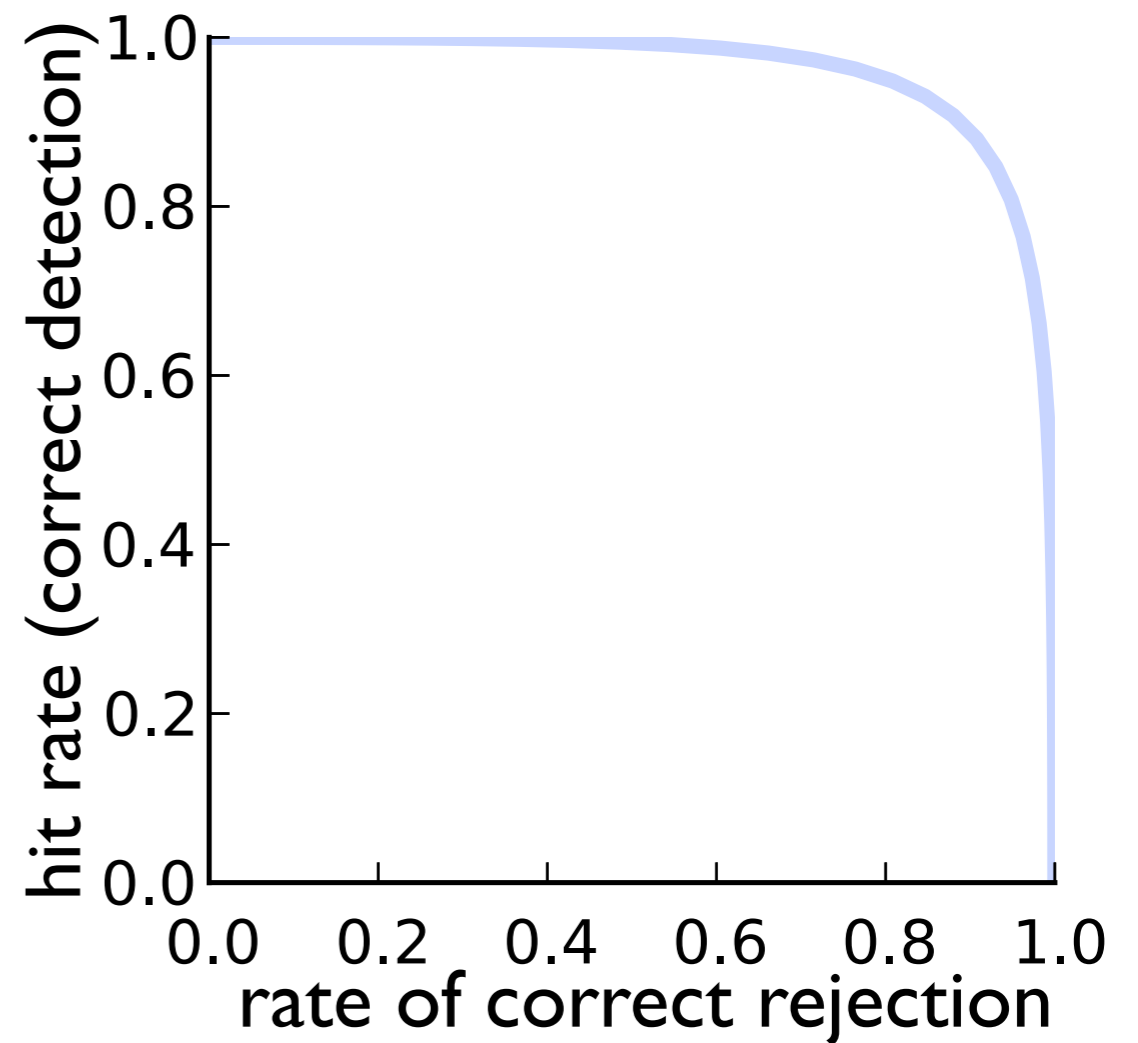
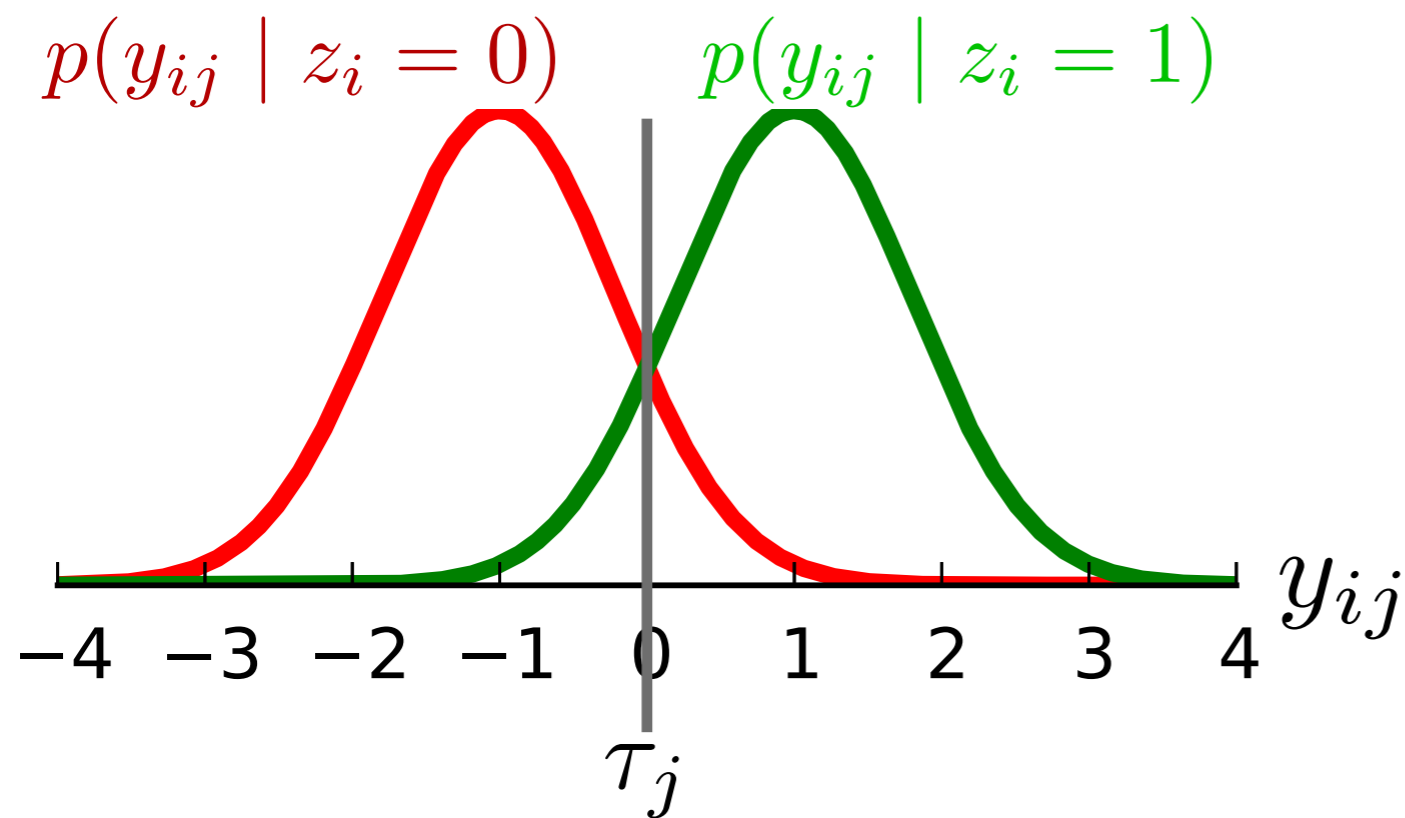

Optimists and pessimists: τ_j

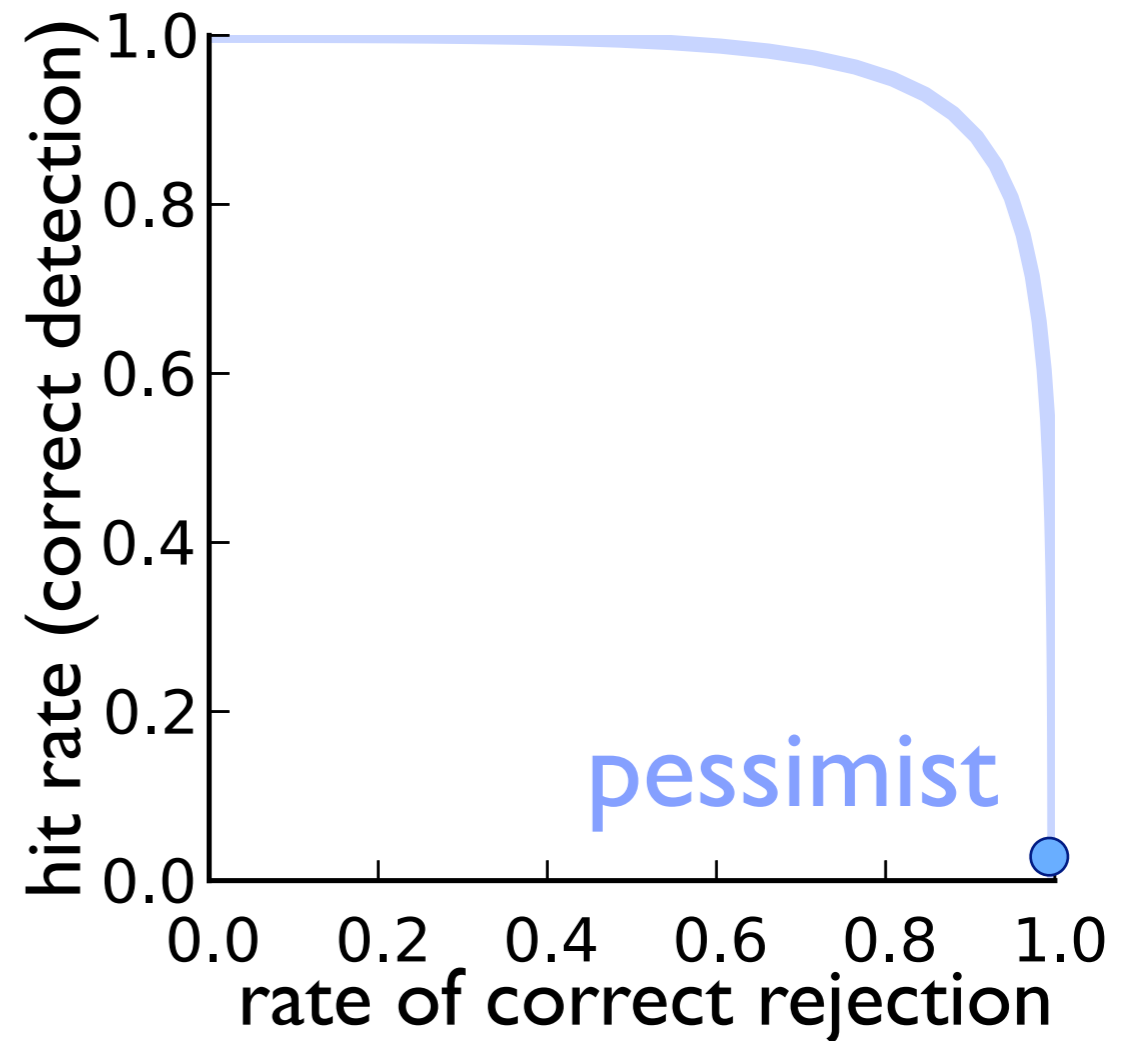
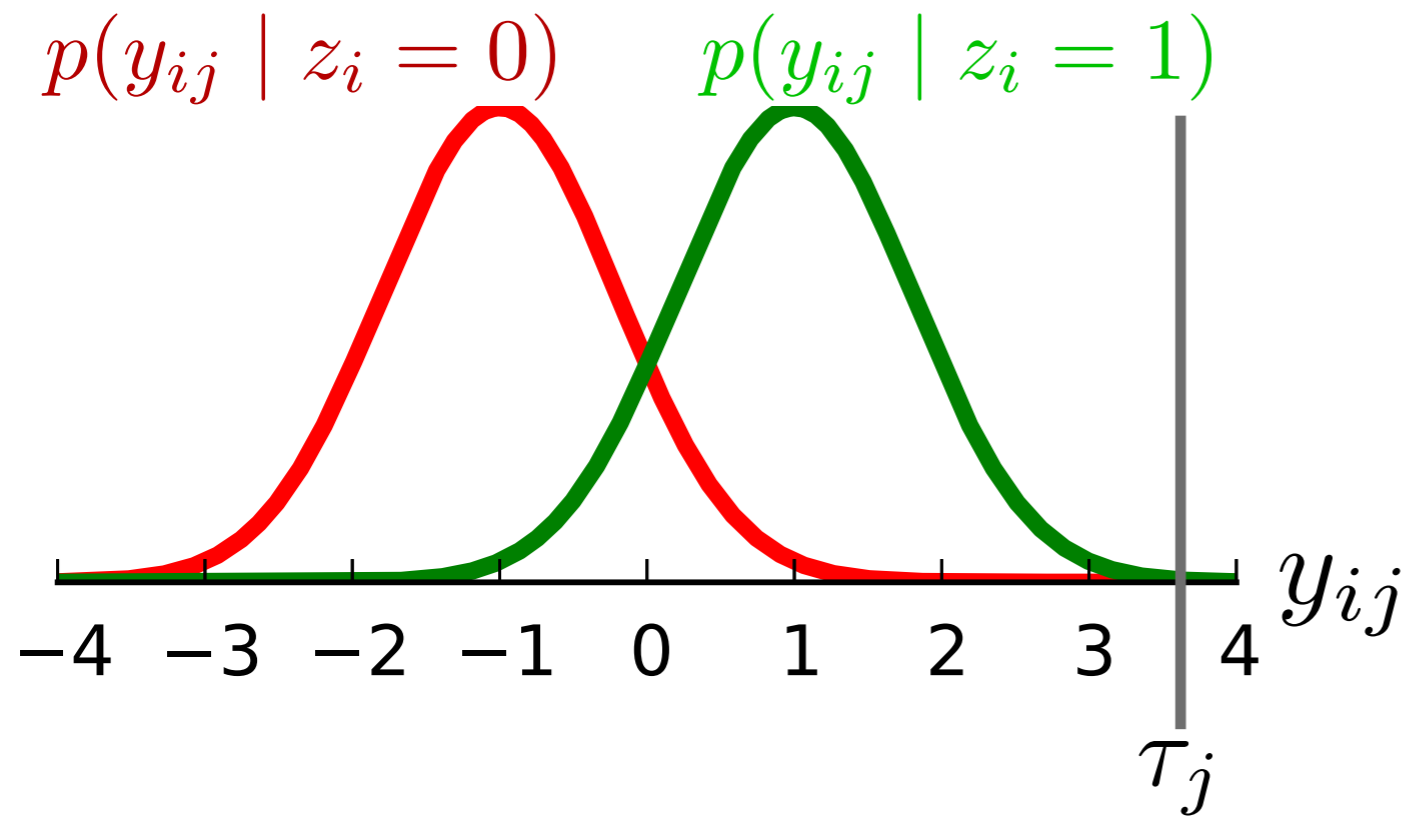

Optimists and pessimists: τ_j

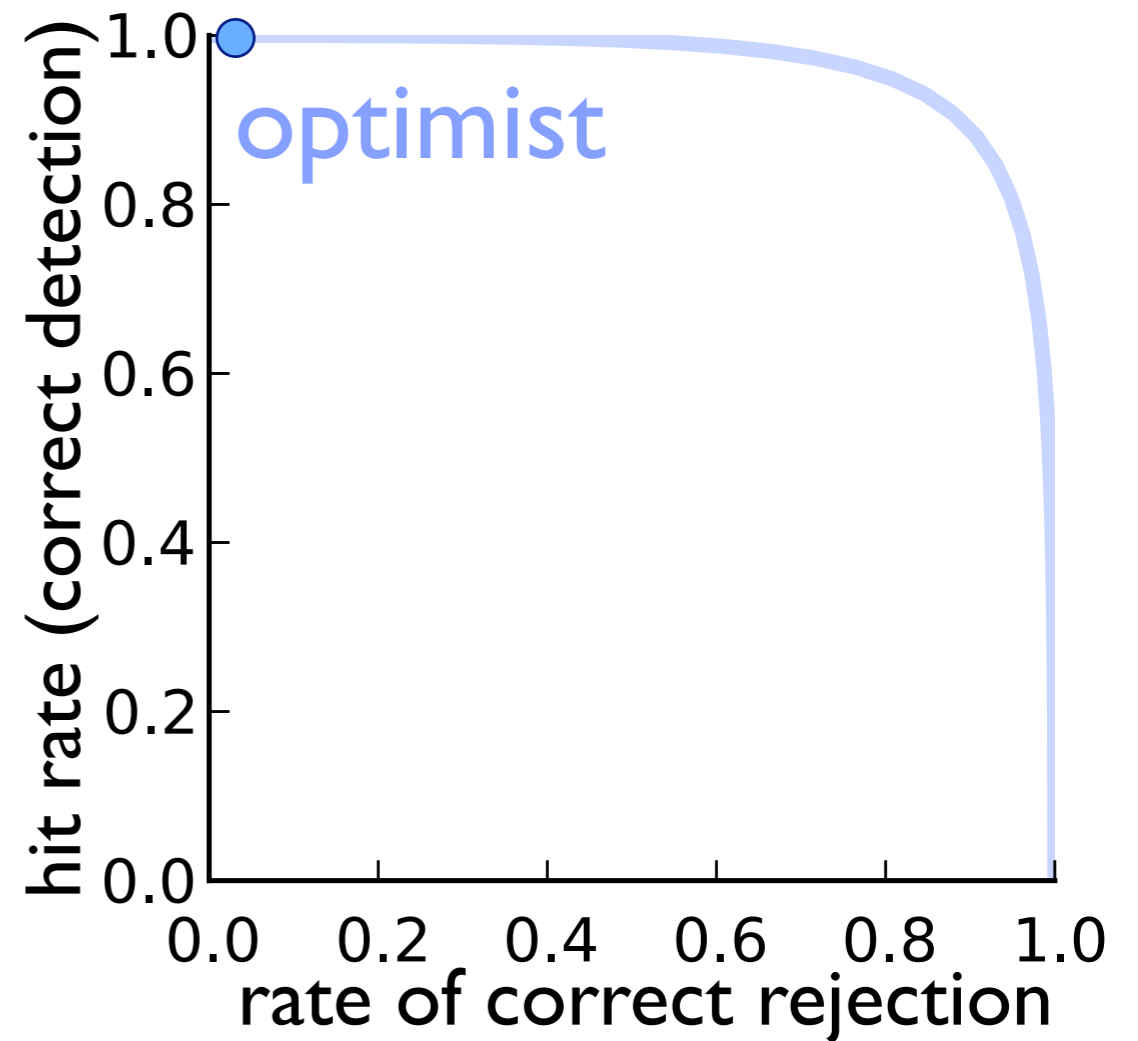
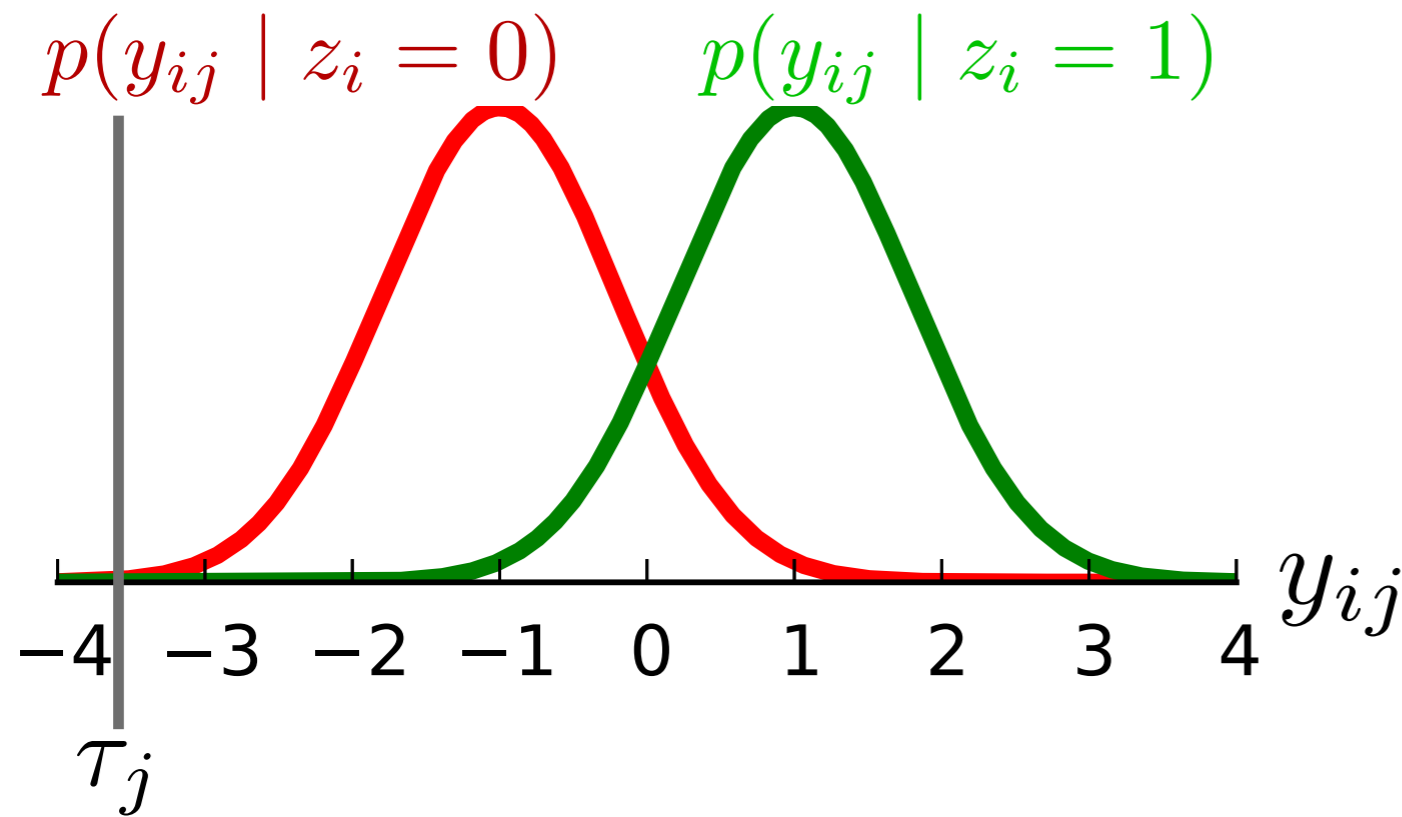

Optimists and pessimists: τ_j

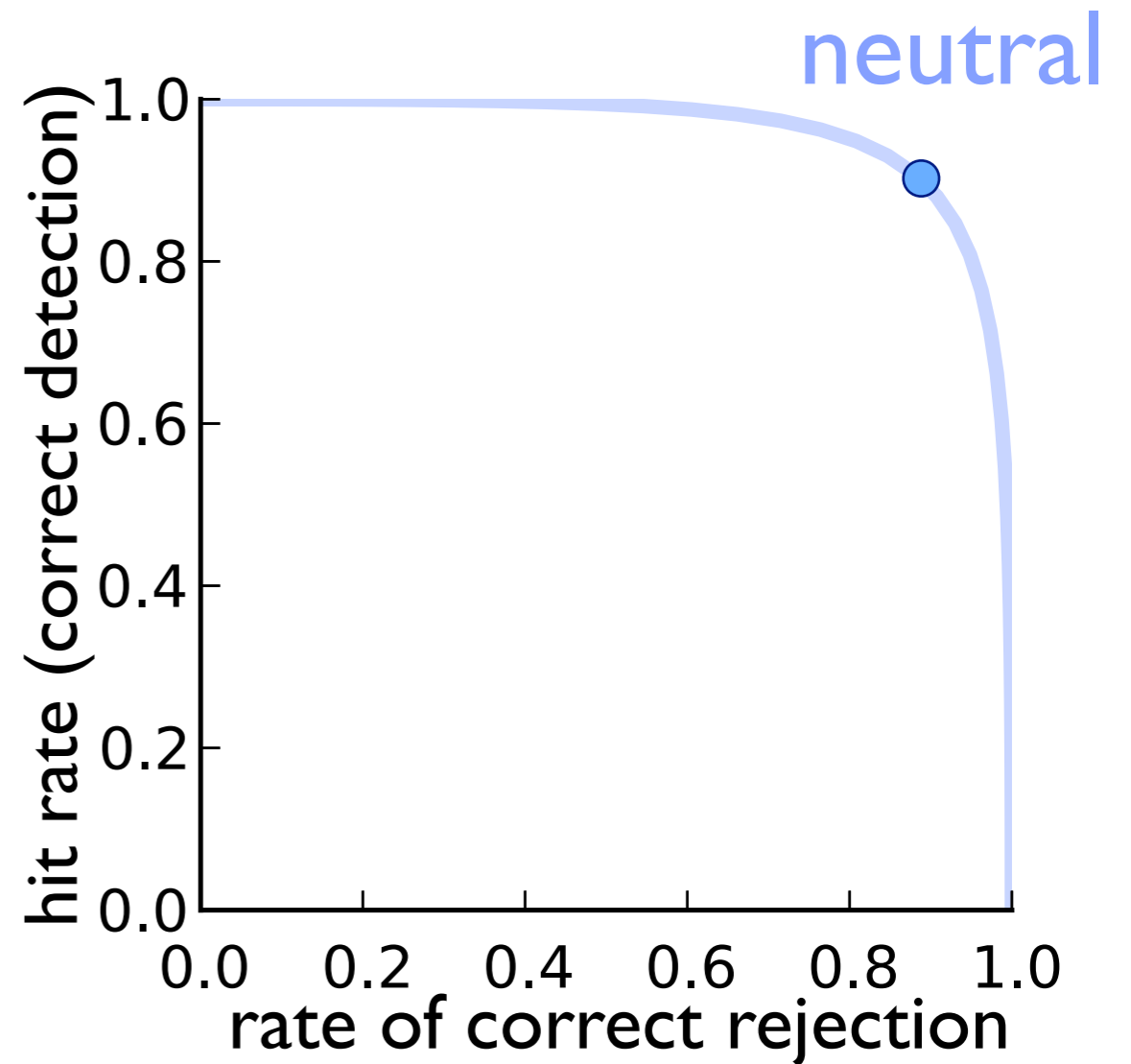
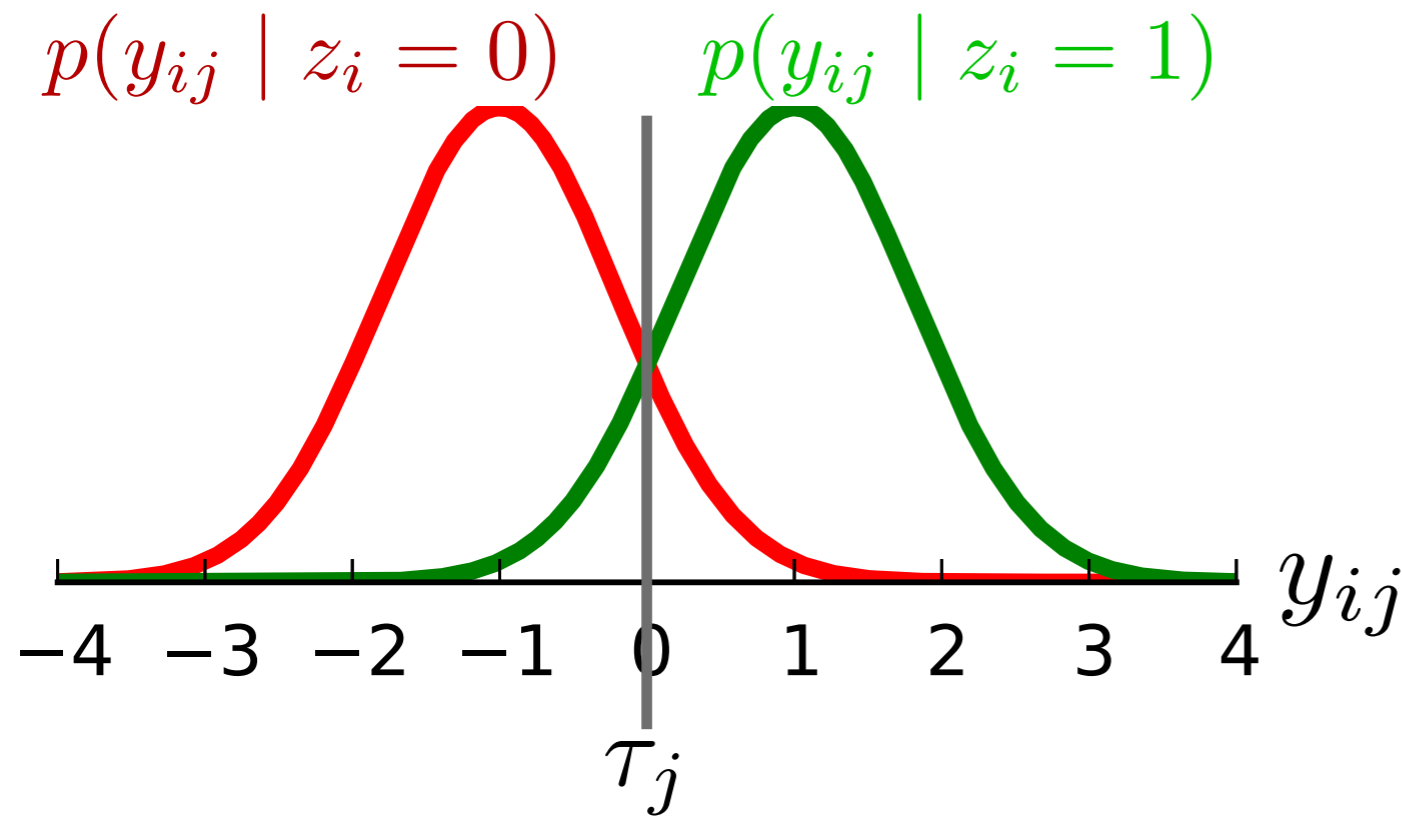

Multidimensional signals and annotators

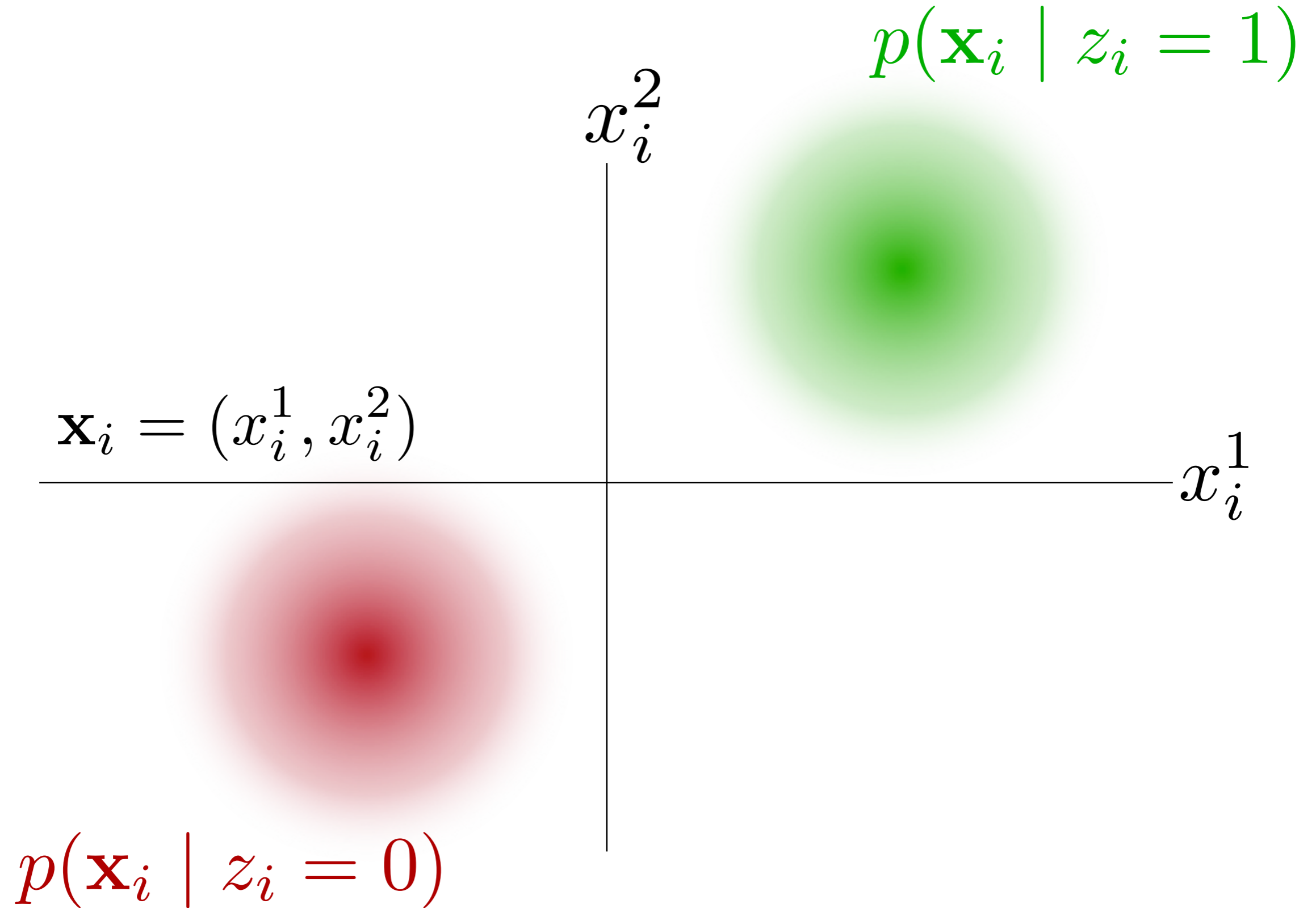

Multidimensional signals and annotators

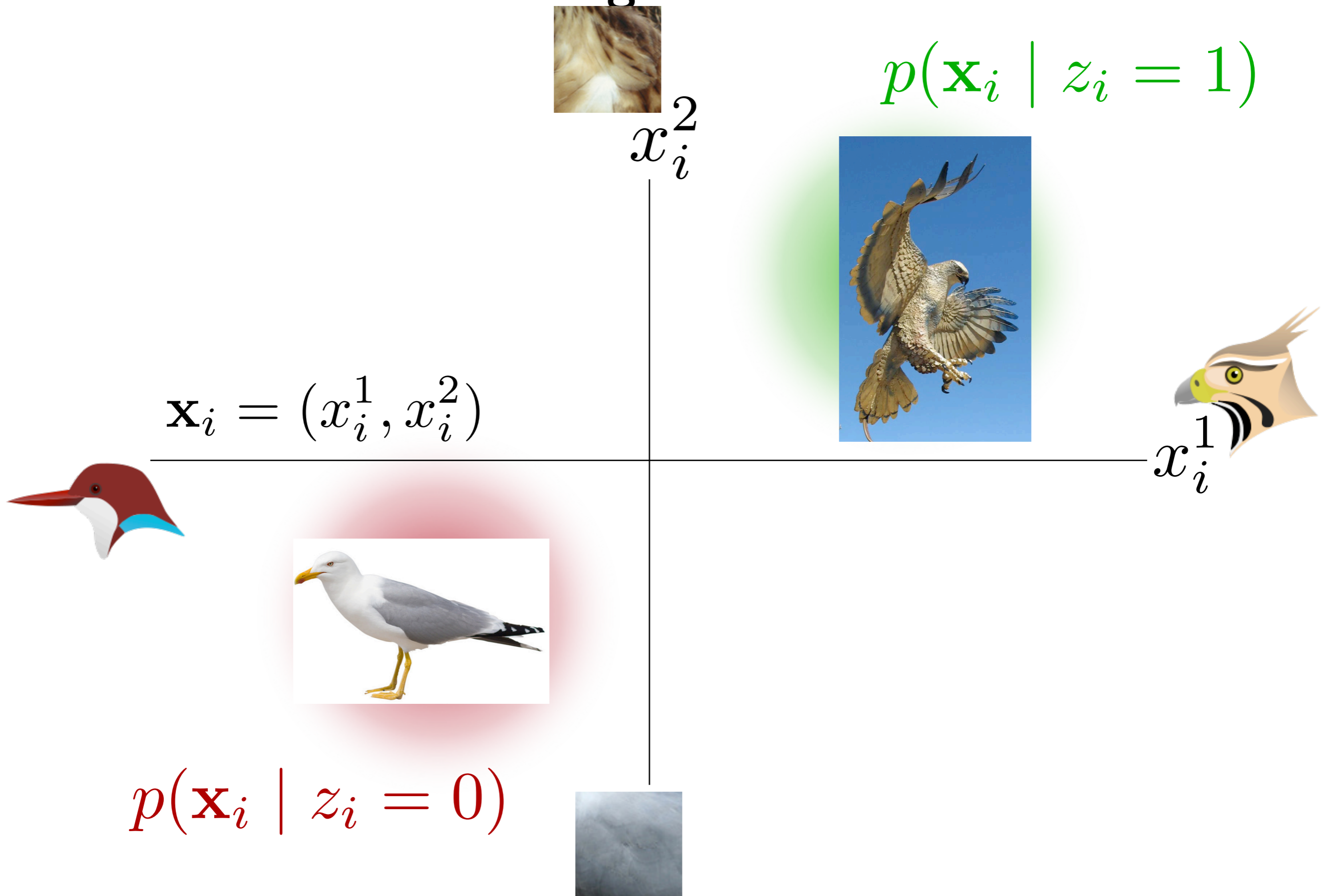

Multidimensional signals and annotators

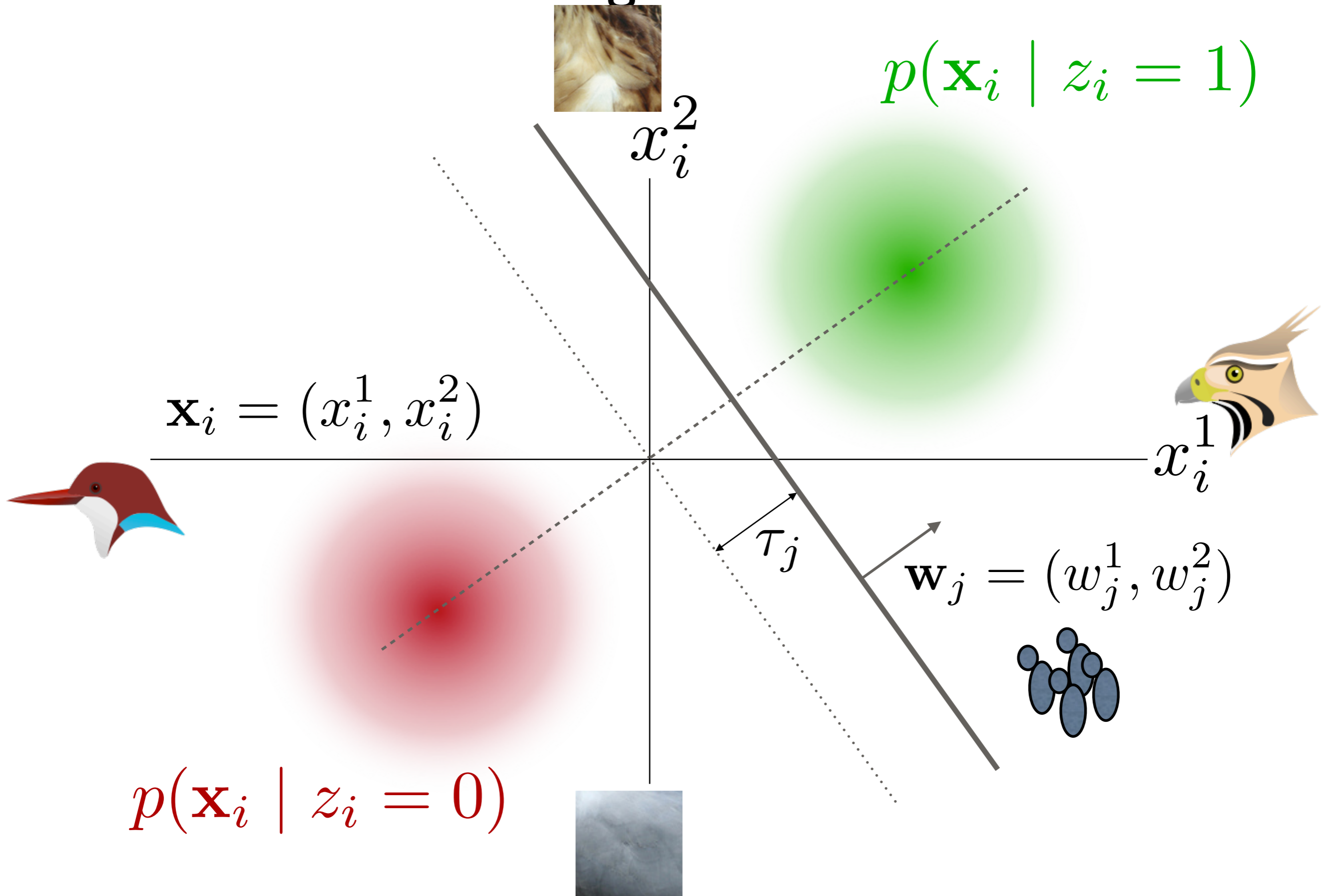

Full model

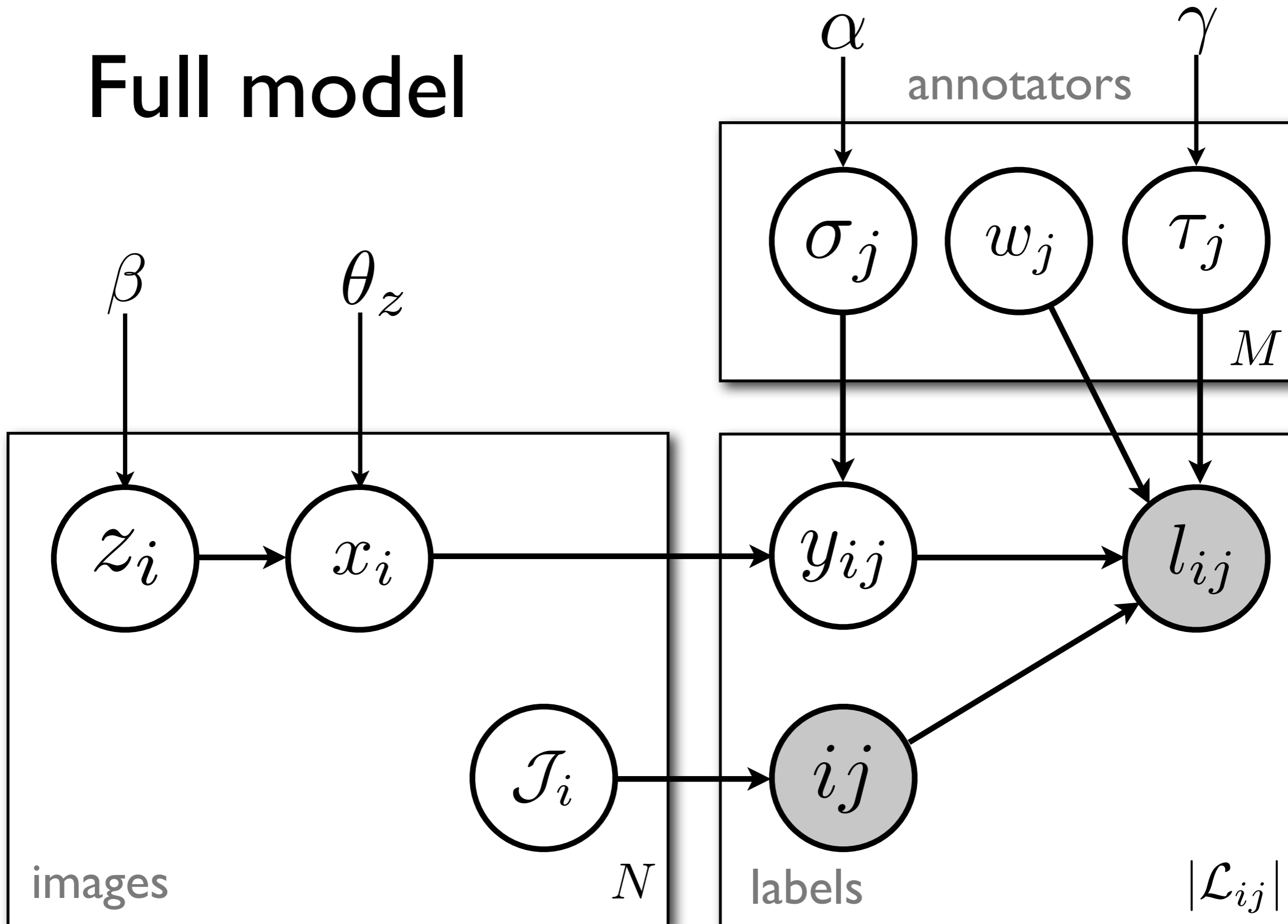

Full model

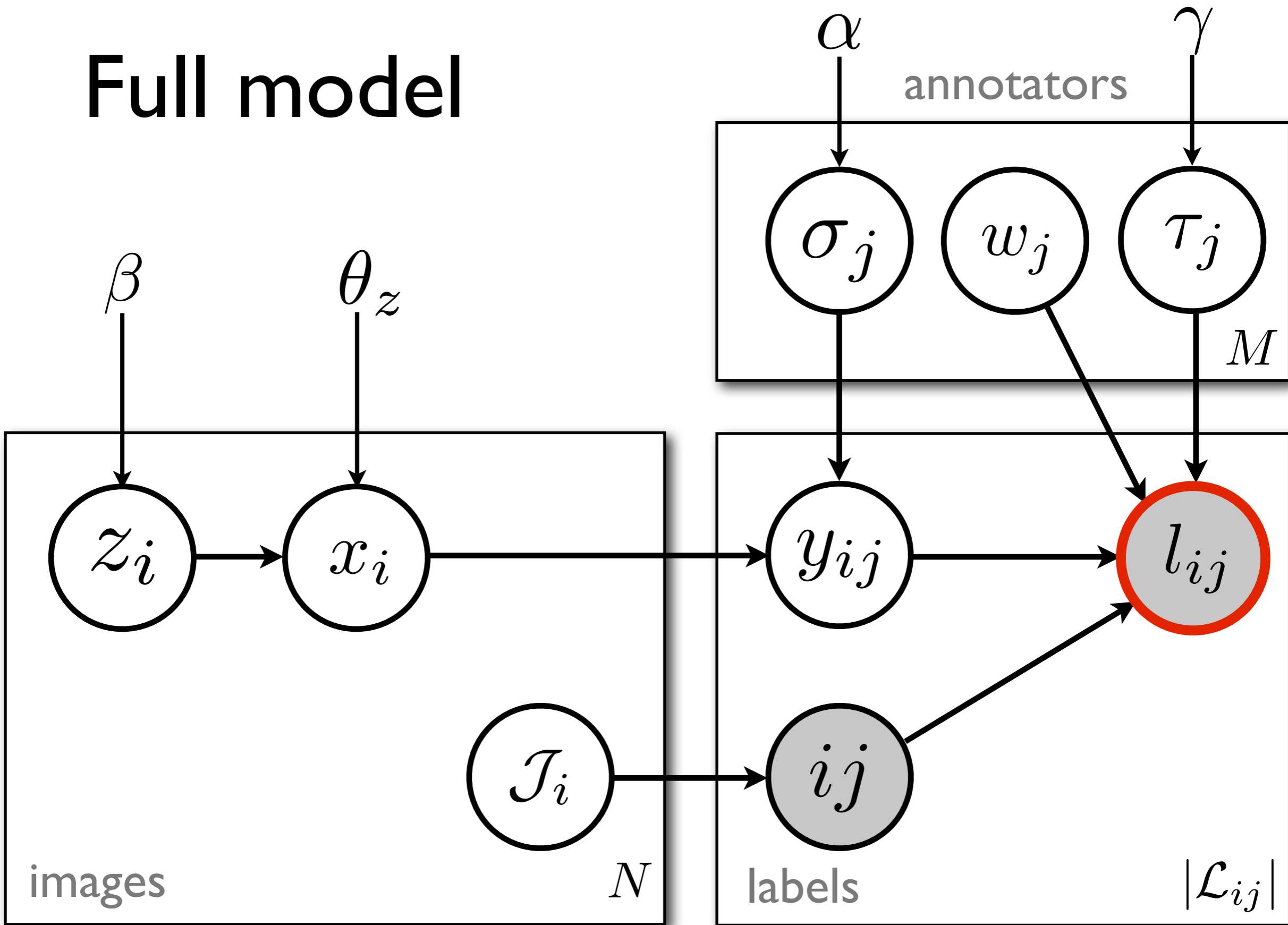

Full model

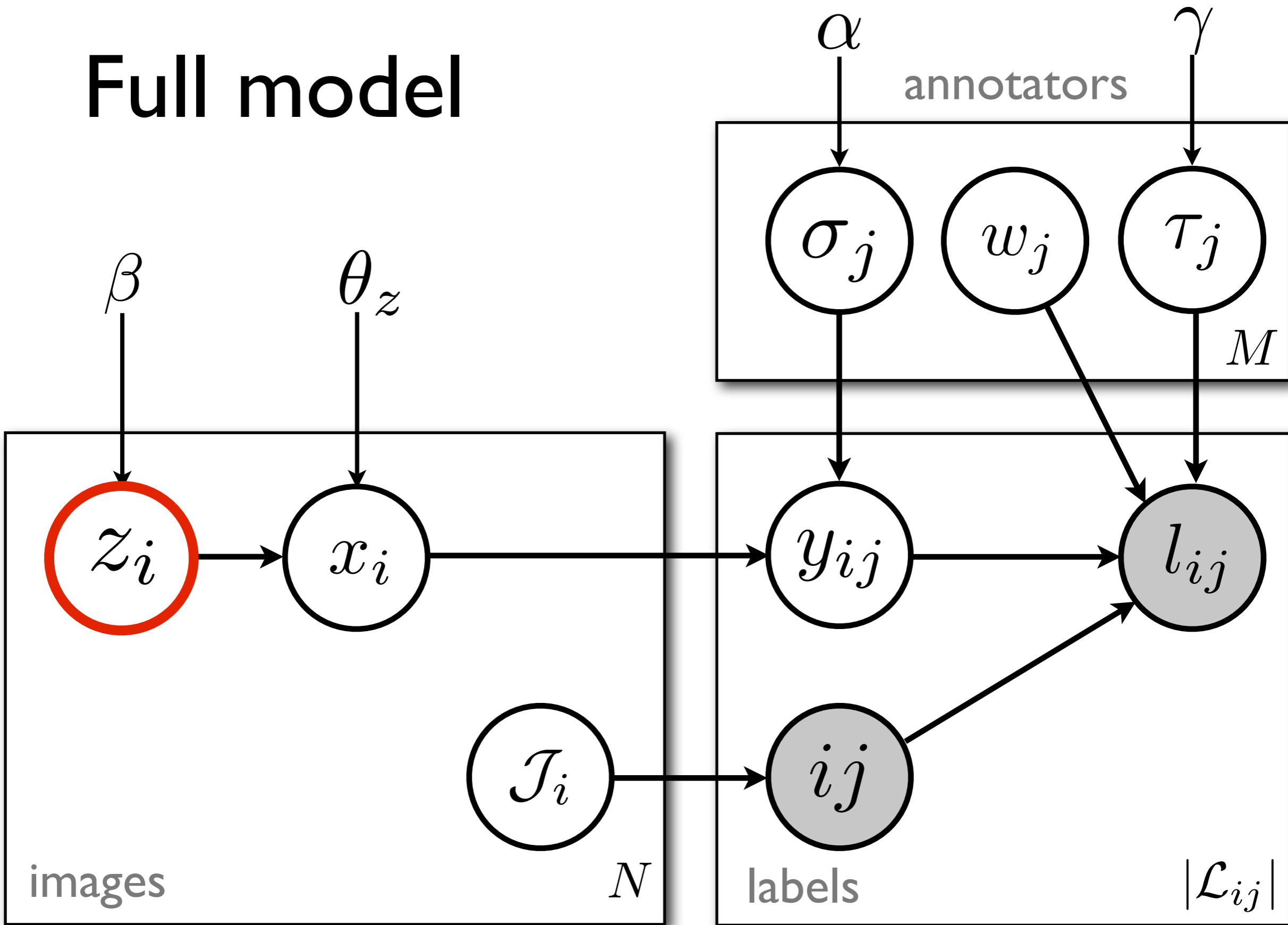

Full model

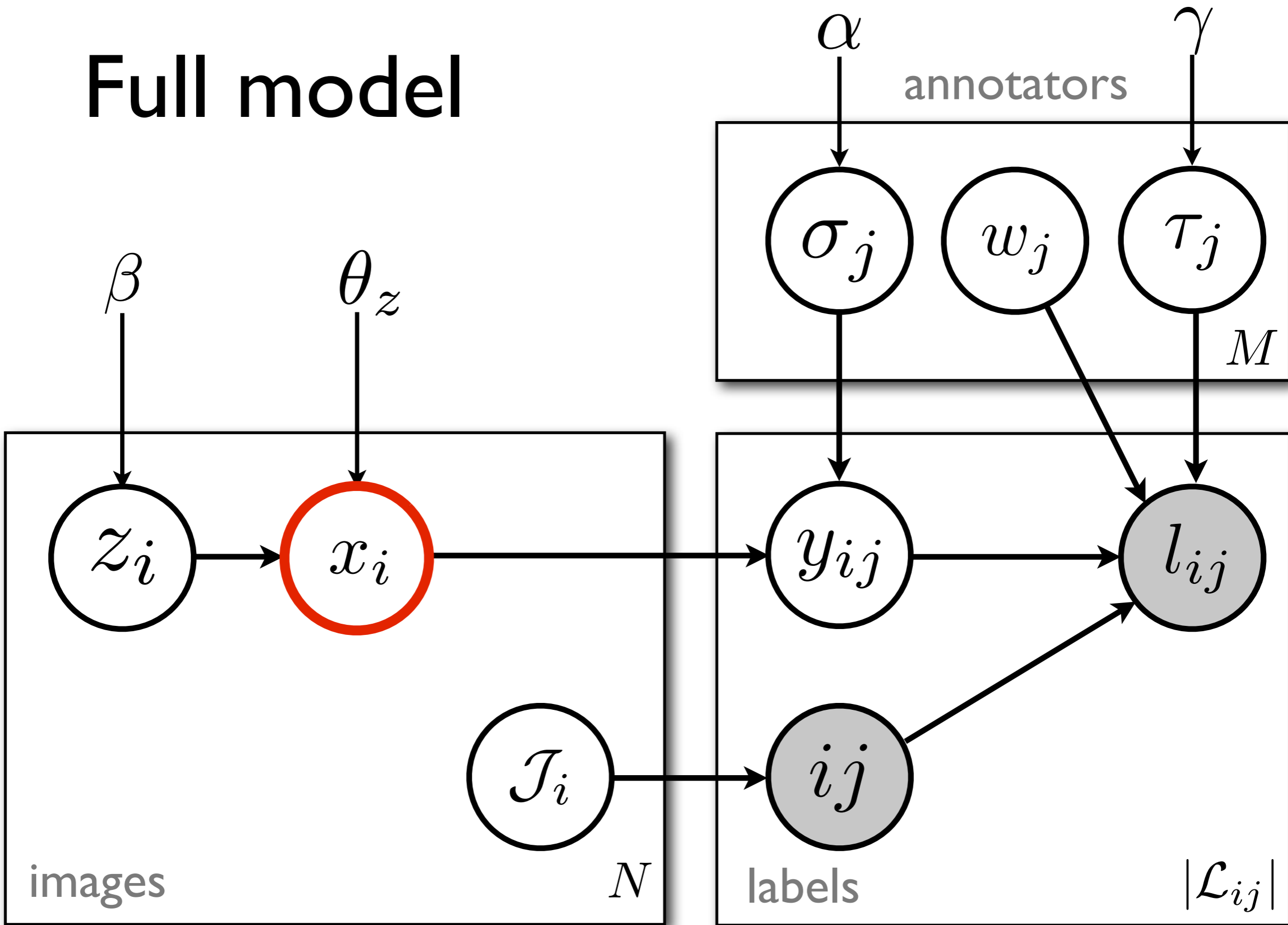

Full model

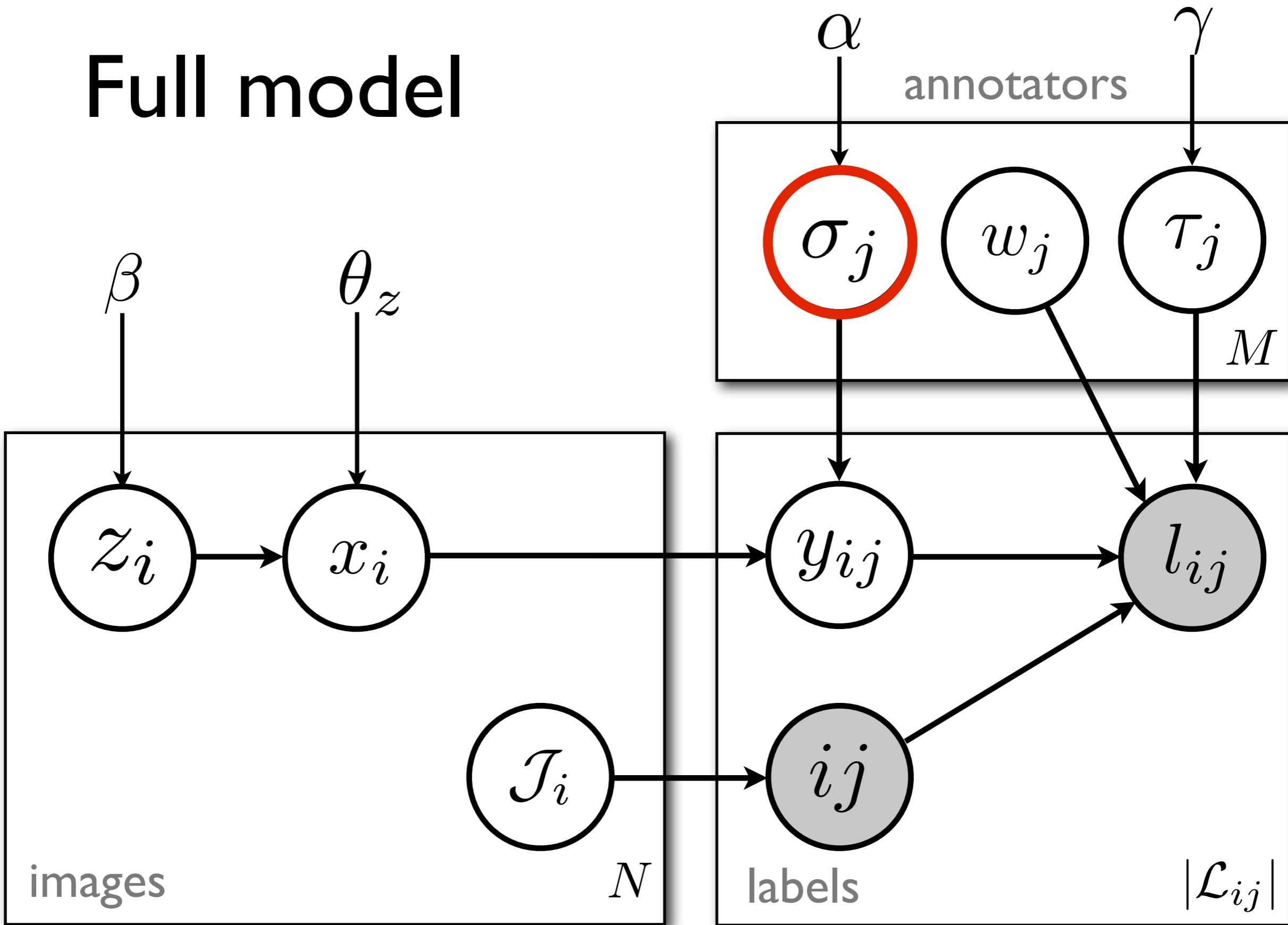

Full model

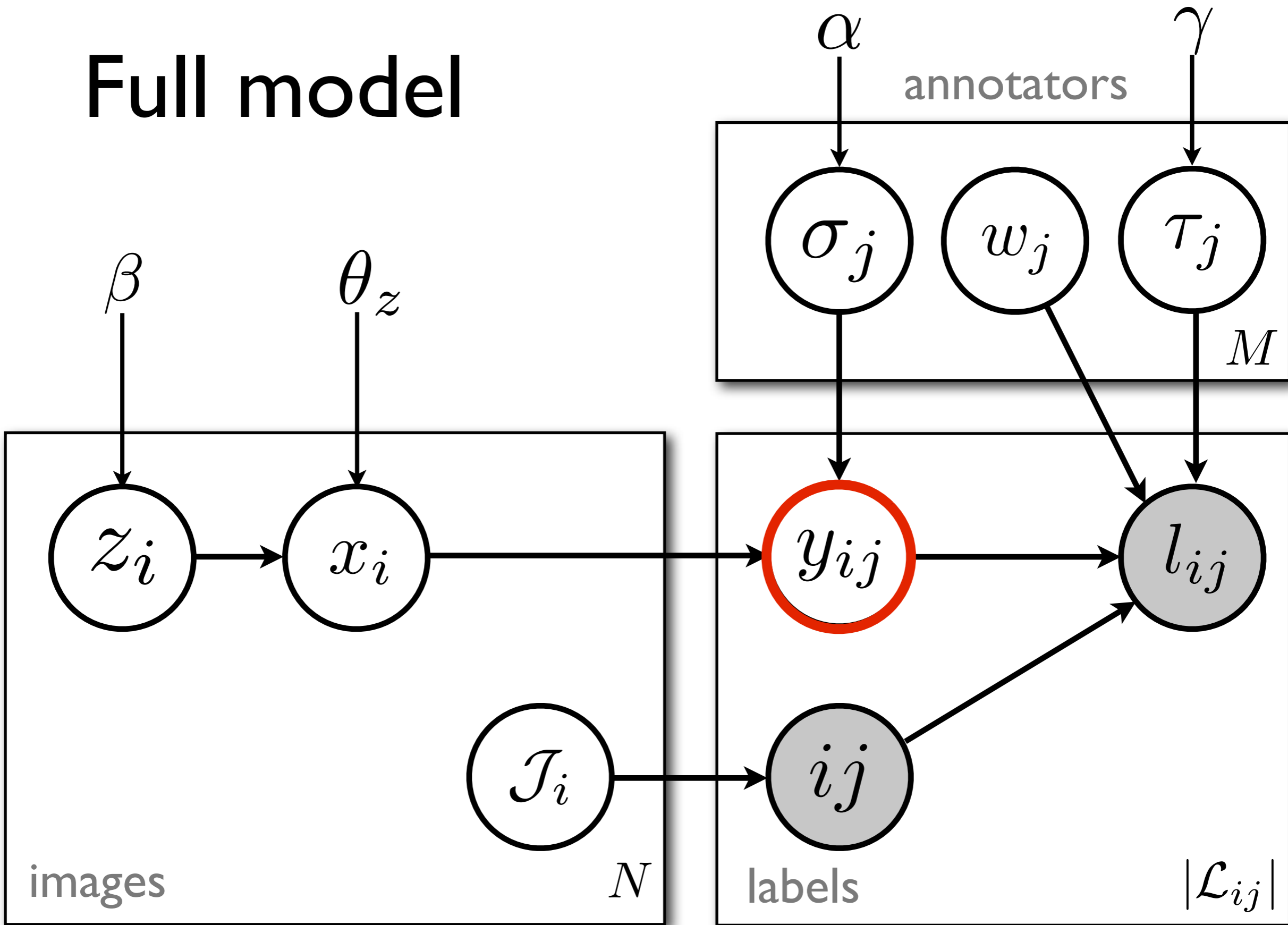

Full model

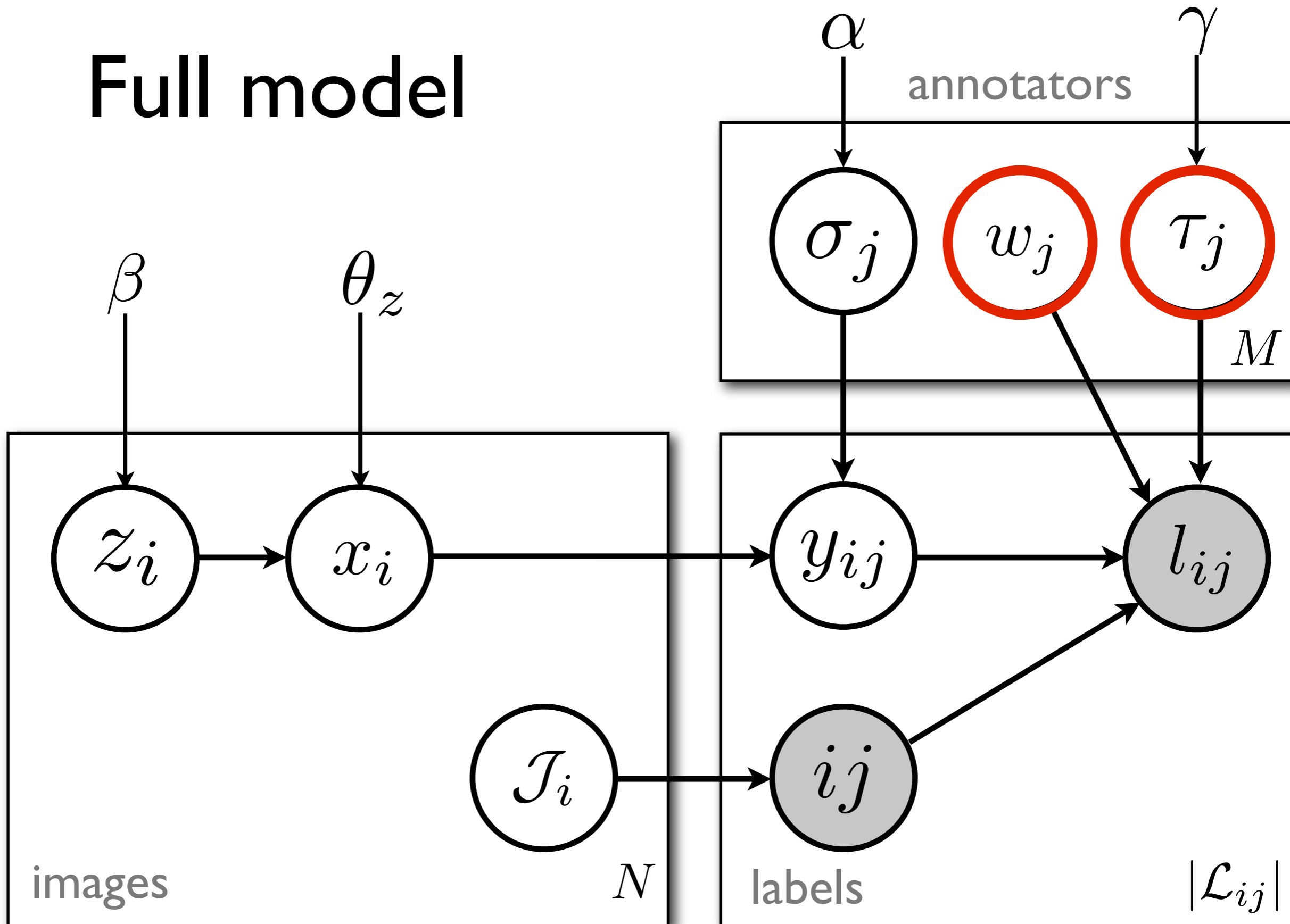

Full model

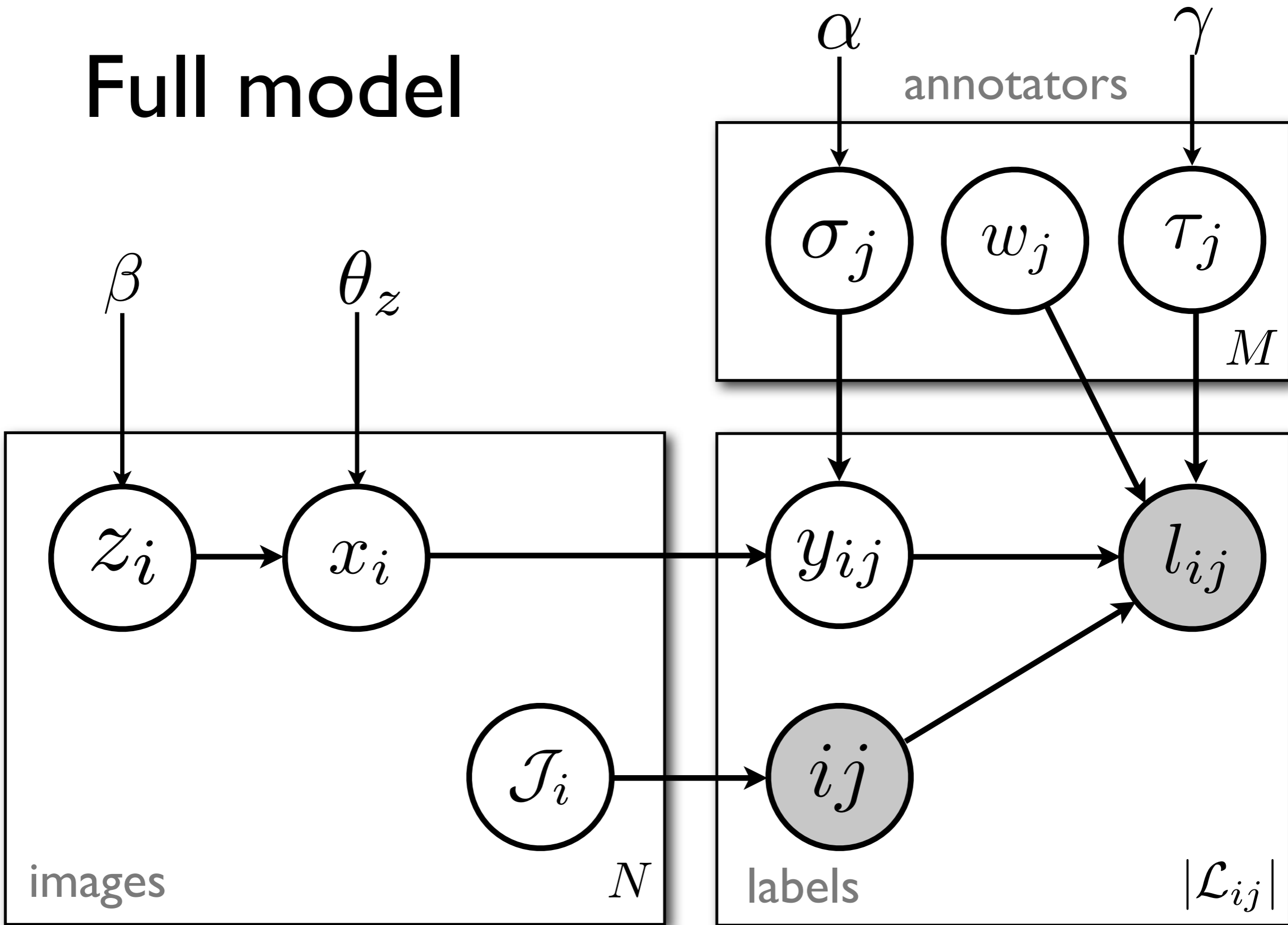

Experiments: estimating z_i

Indigo Bunting

Blue Grosbeak

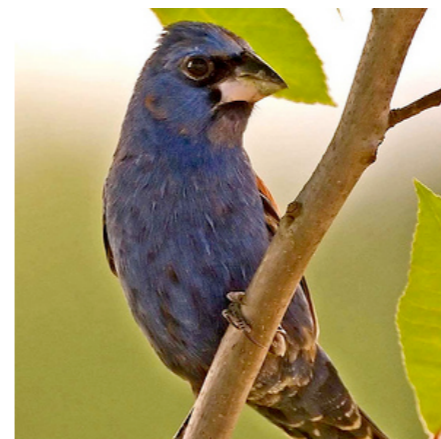

Experiments: estimating z_i

Annotators

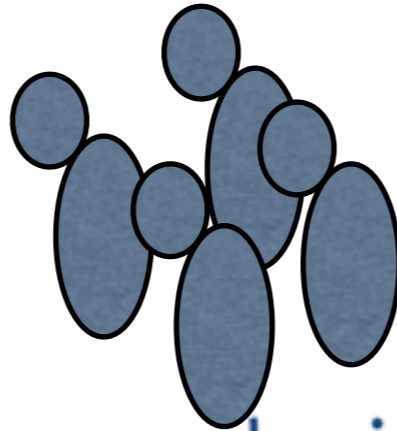

amazonmechanical turk
beta Artificial Intelligence



Many binary labels

Model + Inference

Experiments: estimating z_i

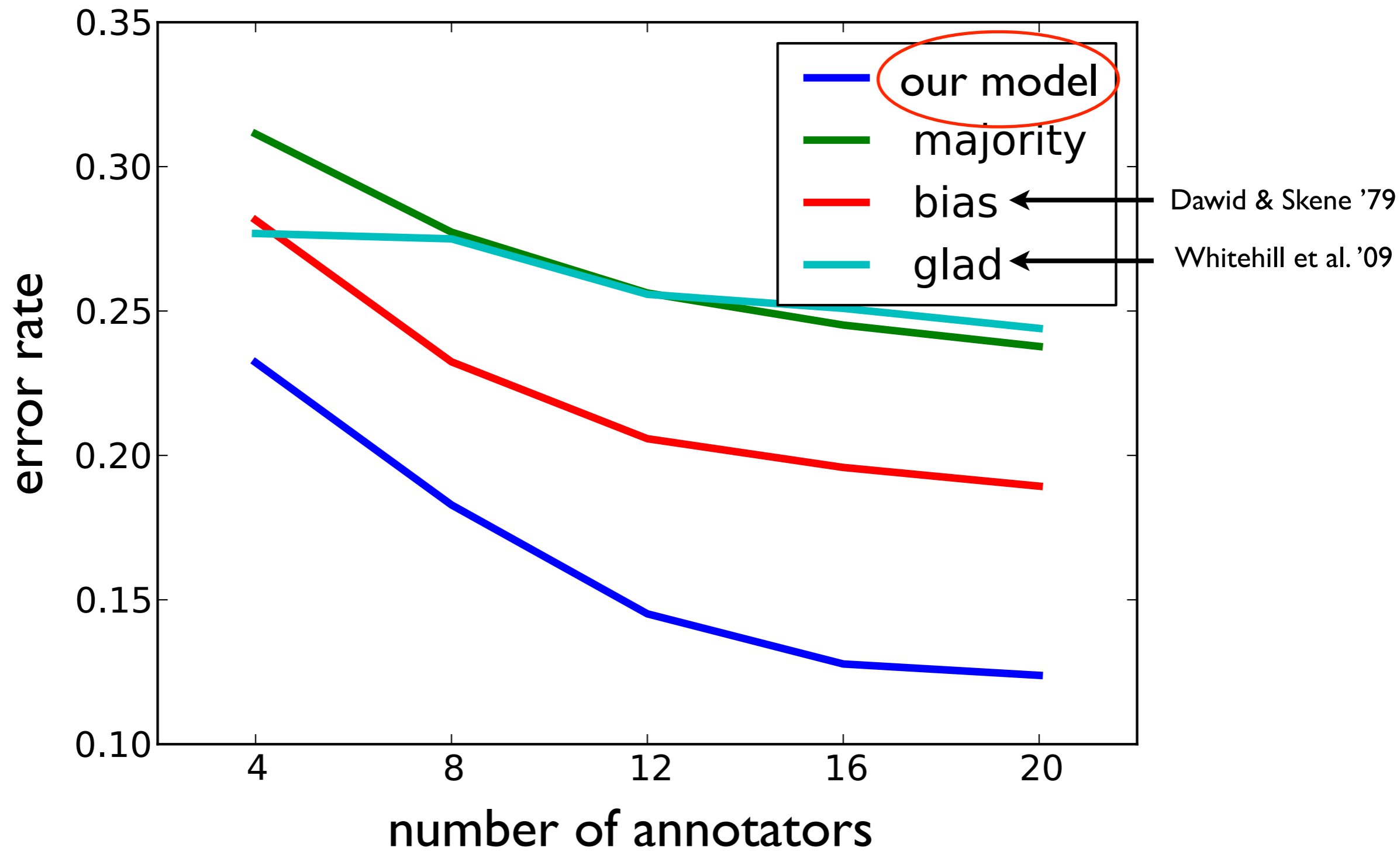

Experiments: estimating z_i

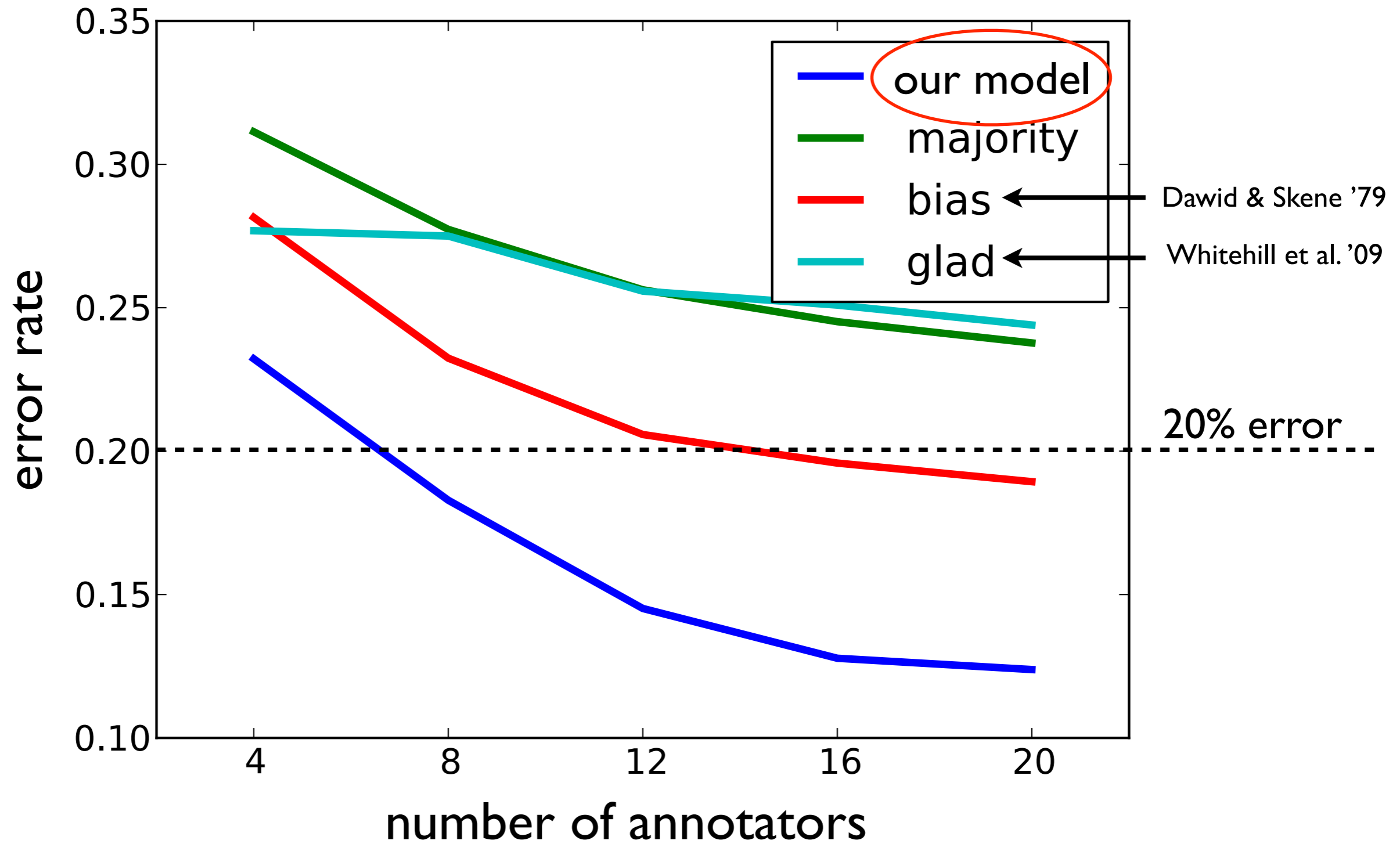

Greebles: estimating multiple attributes

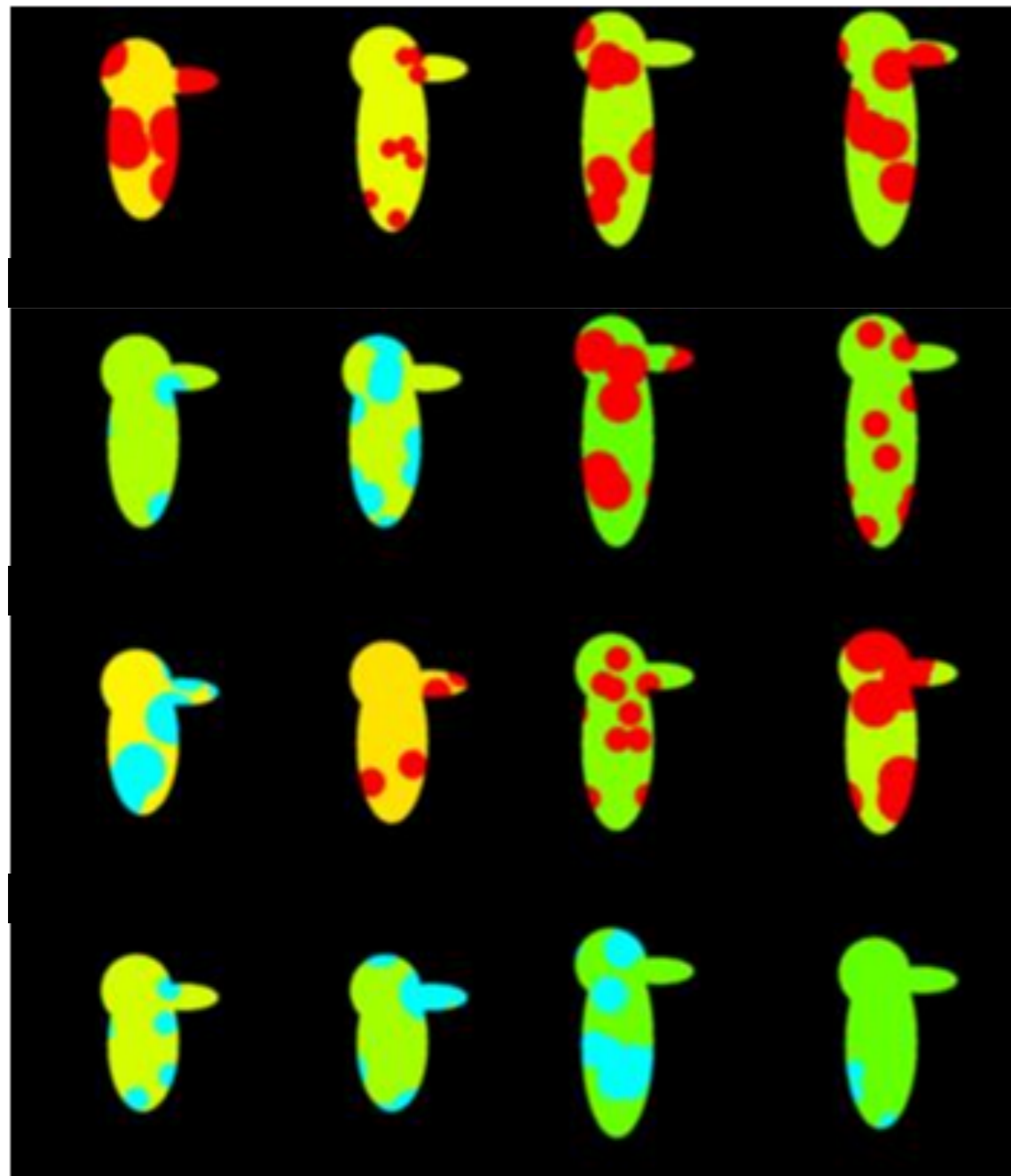

Synthetic figures distinguished by height and color

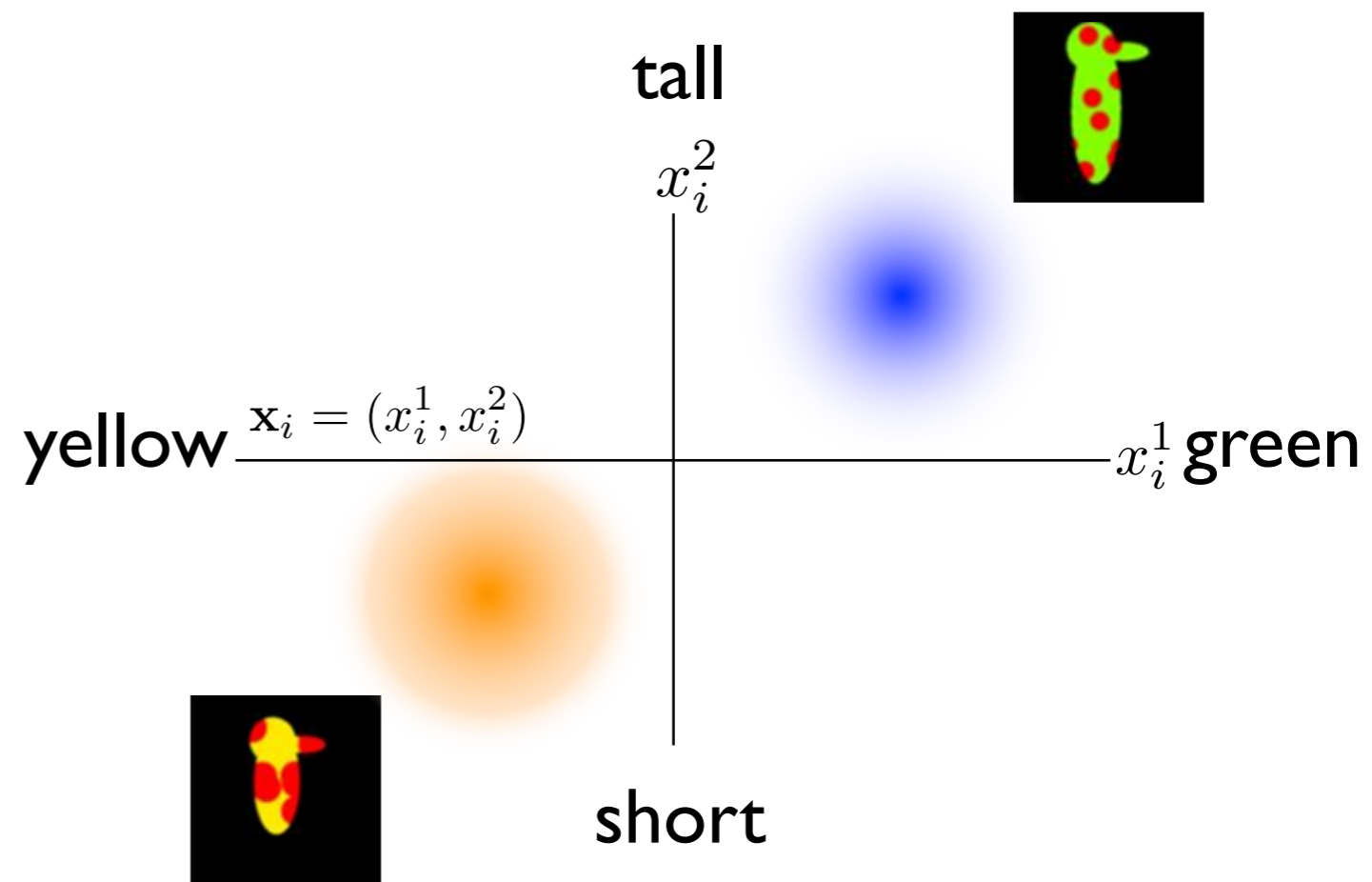

Greebles: estimating multiple attributes

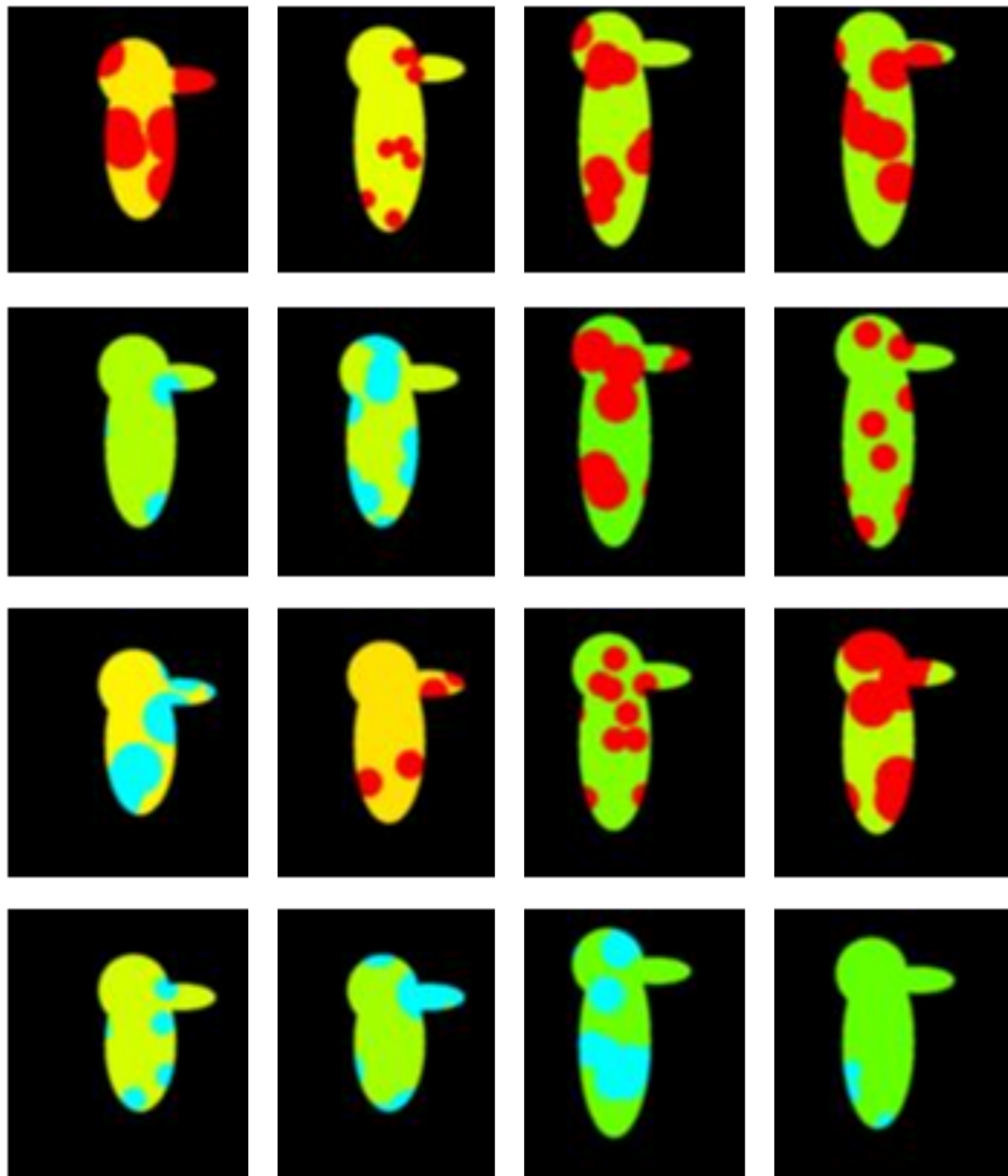

Send to two groups of annotators



Select green greebles



Select tall greebles

Greebles: estimating multiple attributes

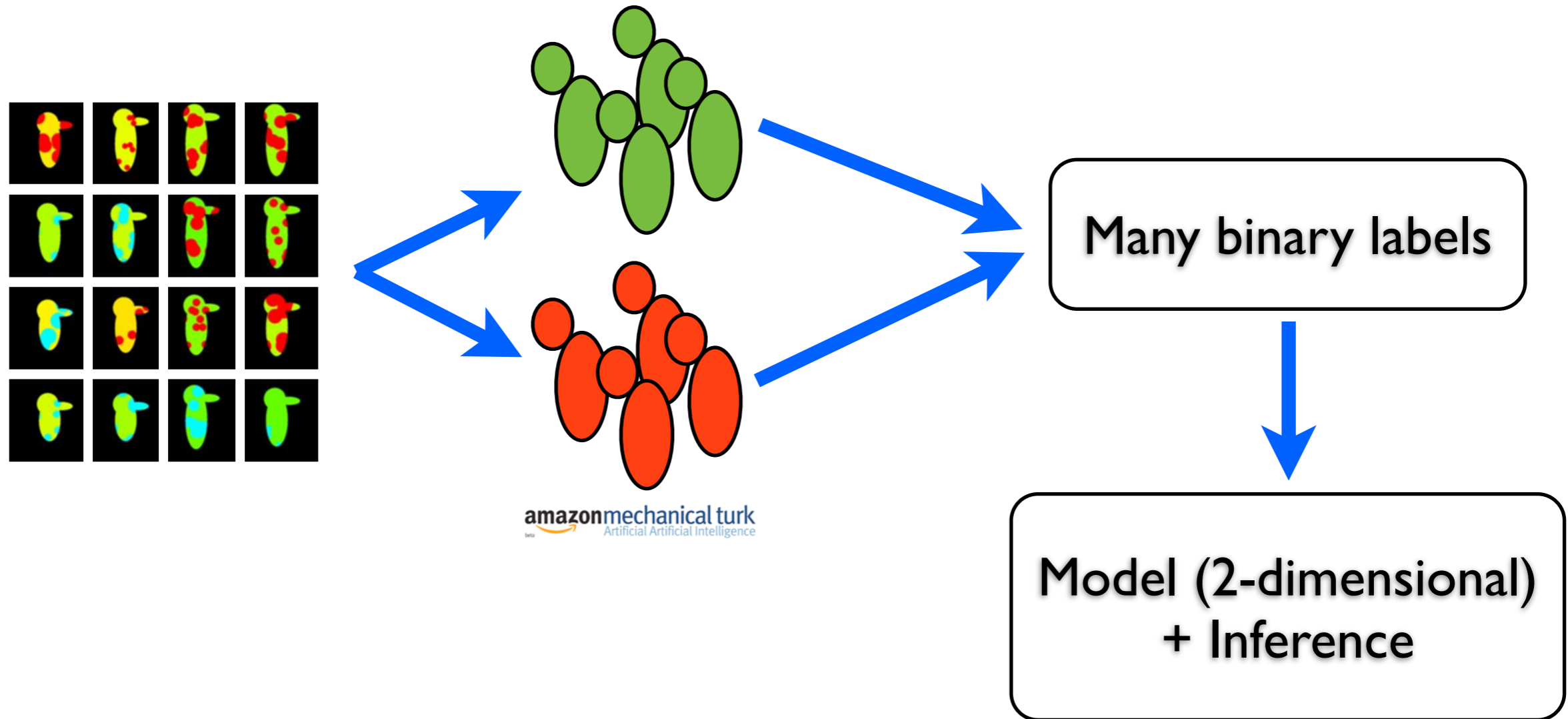

Greebles: estimating multiple attributes

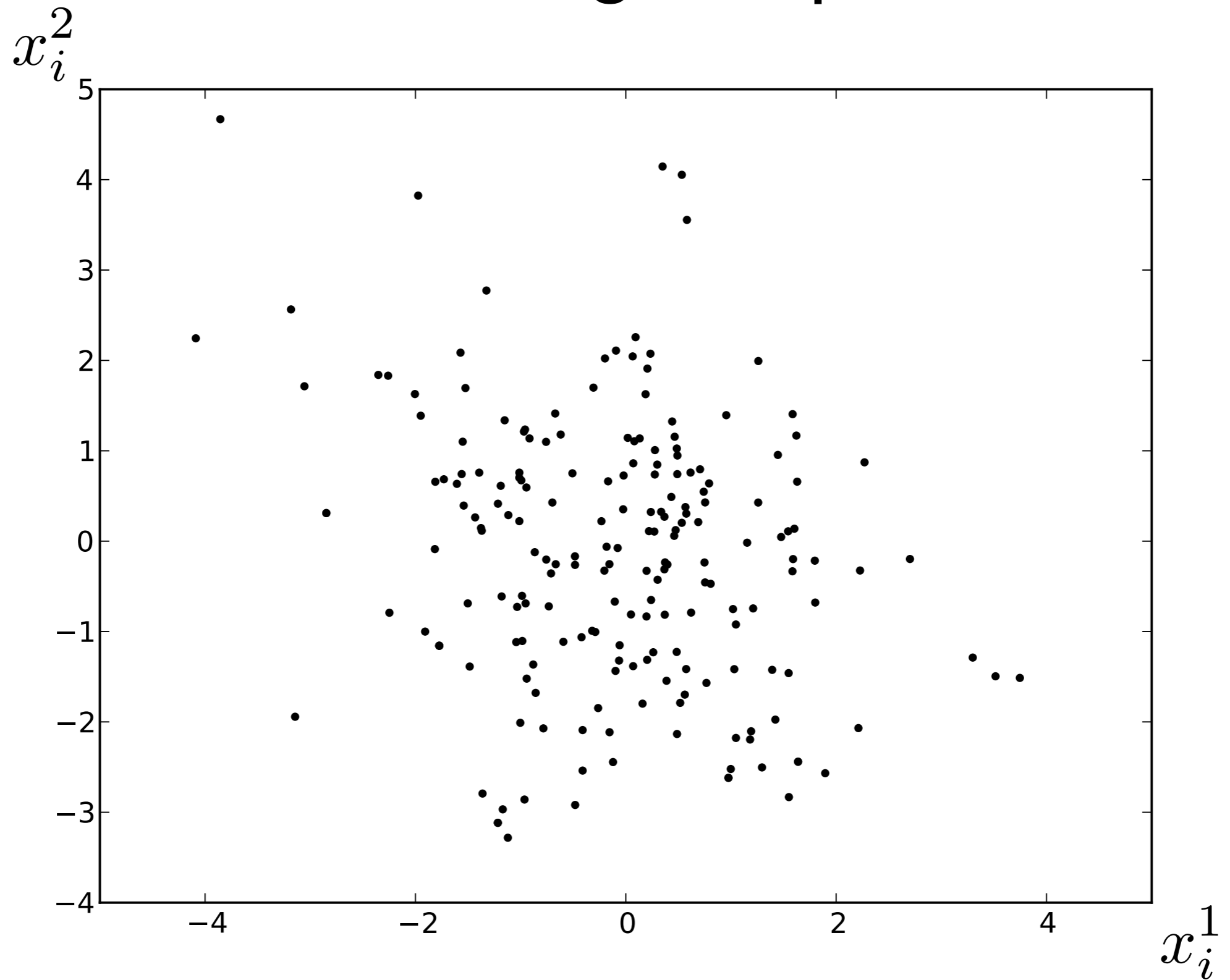

Greebles: estimating multiple attributes

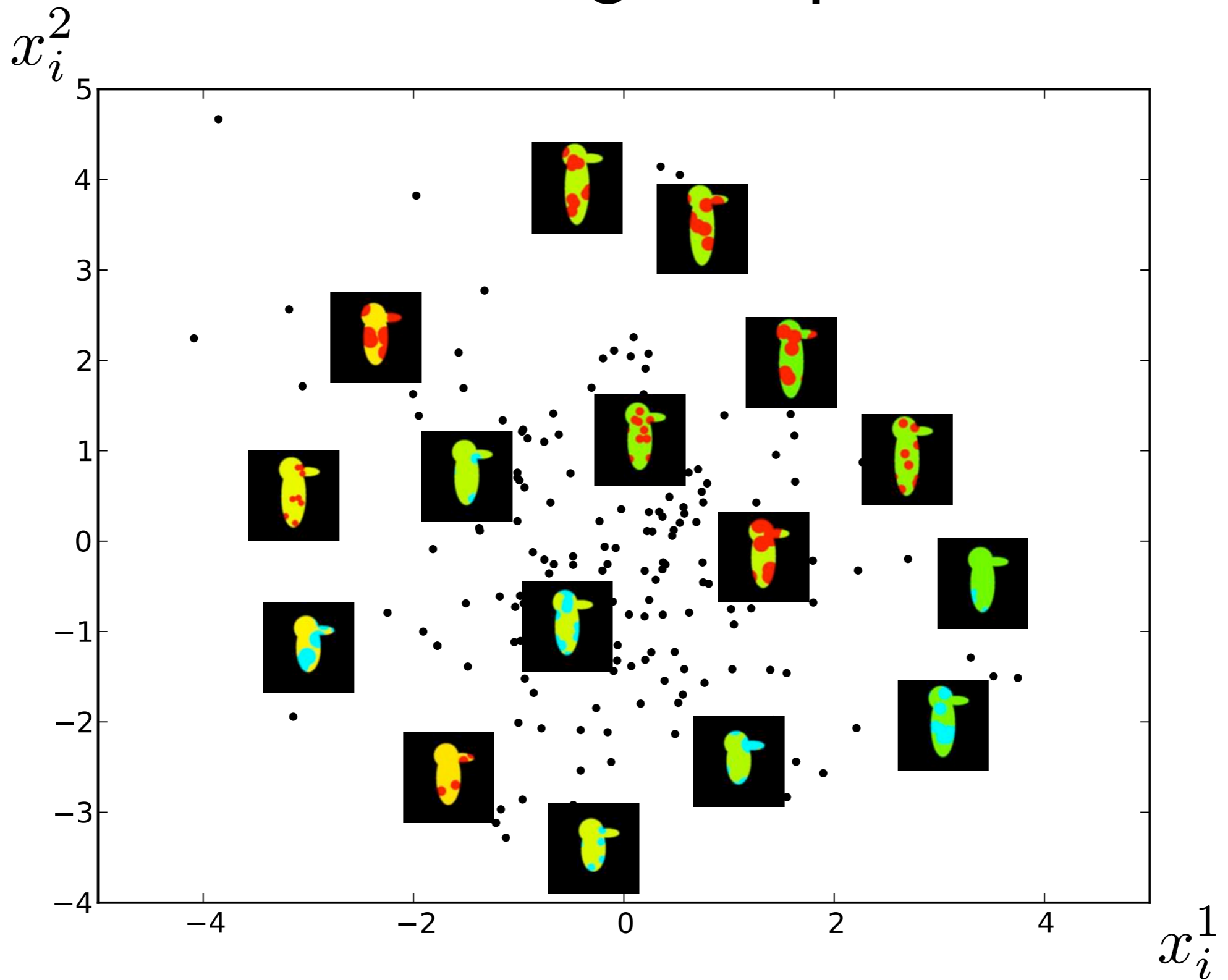

Greebles: estimating multiple attributes

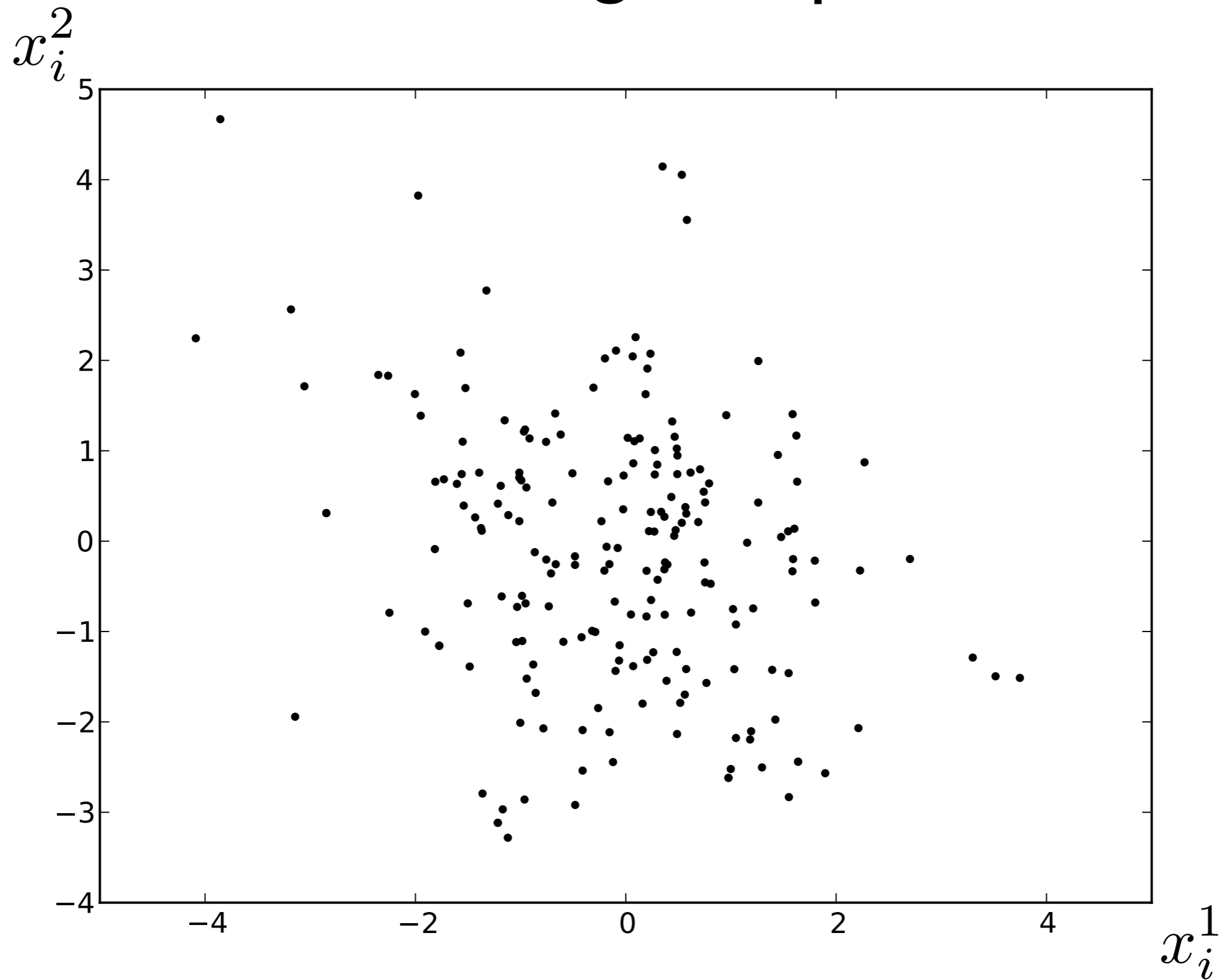

Greebles: estimating multiple attributes

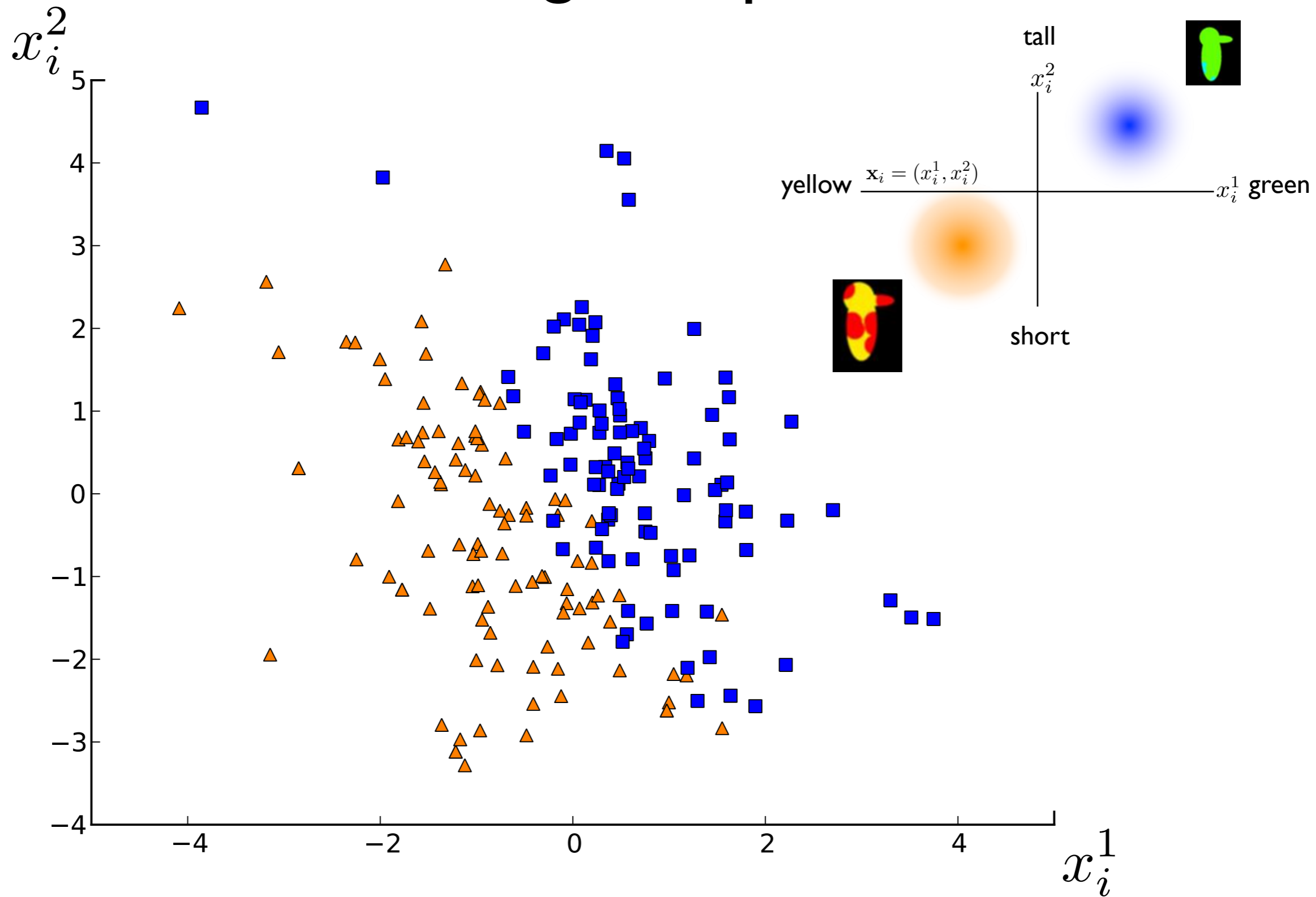

Greebles: estimating multiple attributes

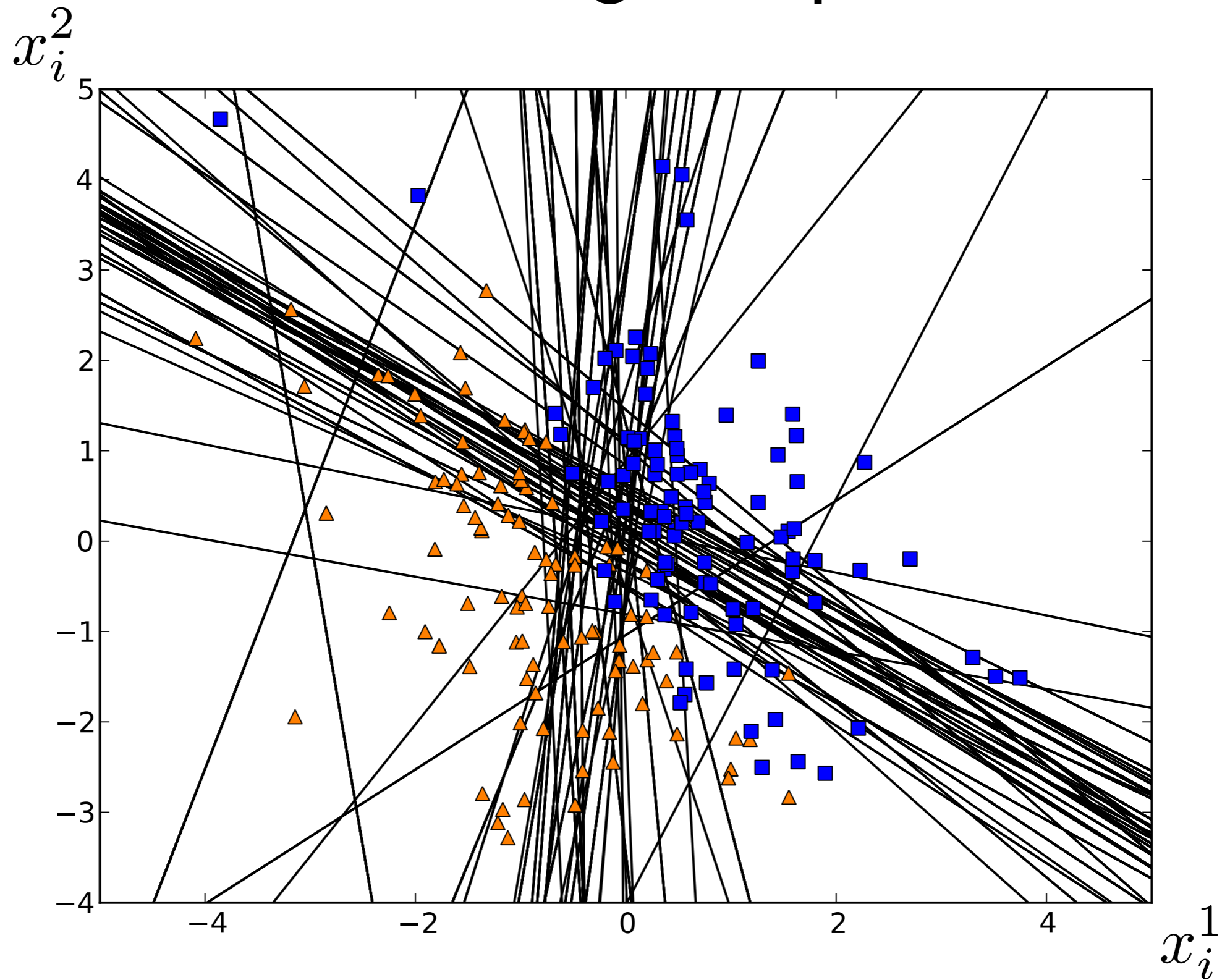

Greebles: estimating multiple attributes

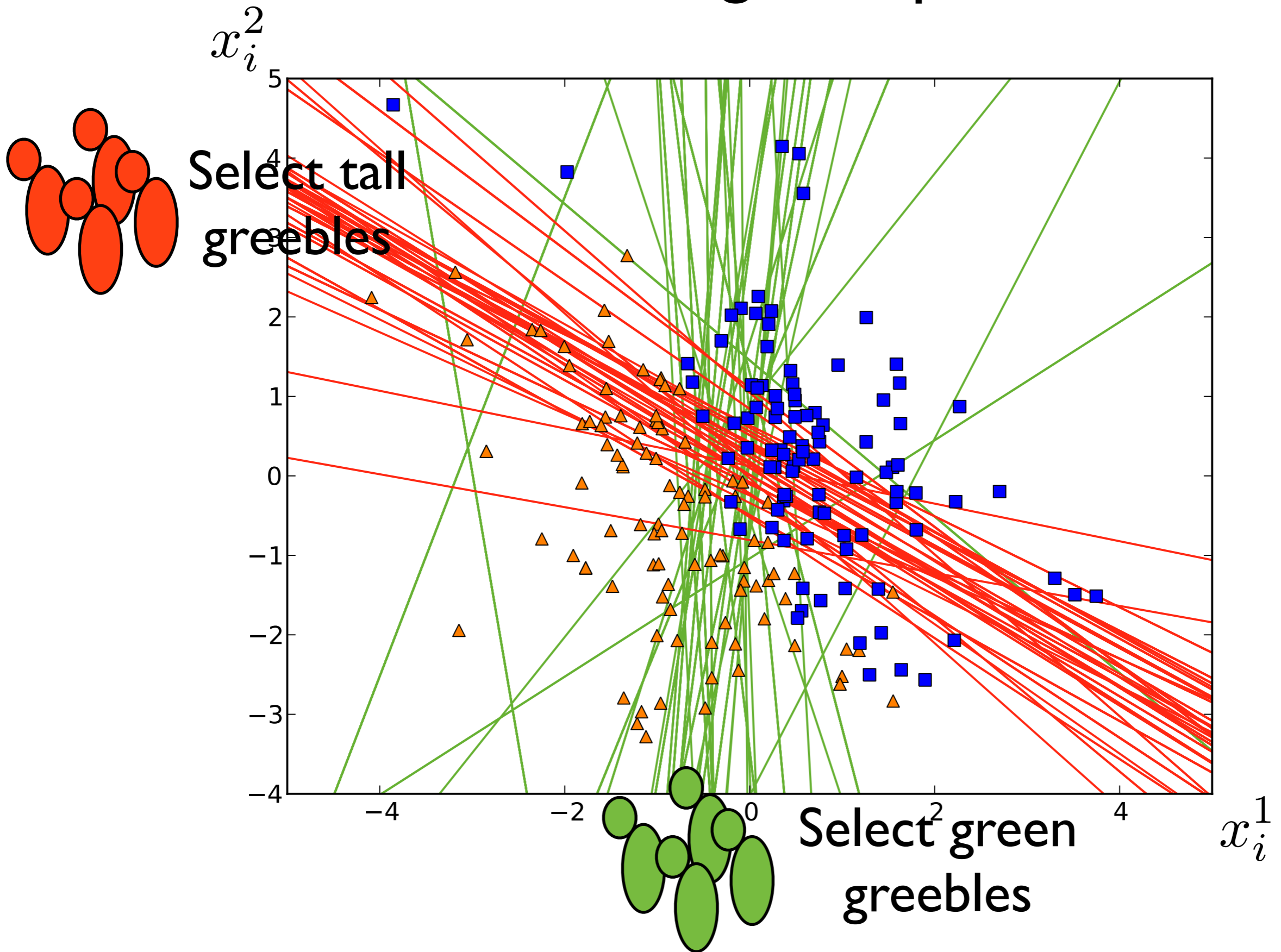

Last Experiment: Waterbirds

Mallard



American Black Duck



Canada Goose



Red Necked Grebe



Non-bird

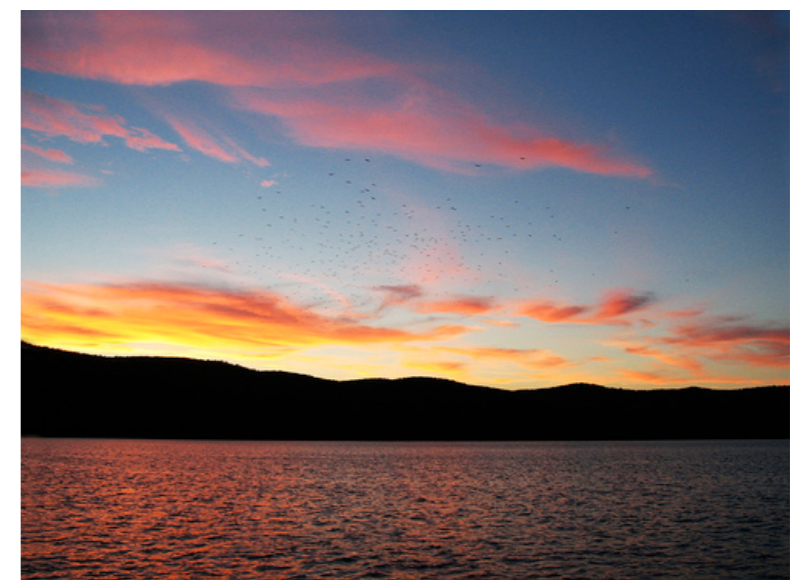

DUCKS

Mallard



American Black Duck



Canada Goose



Red Necked Grebe



Non-bird

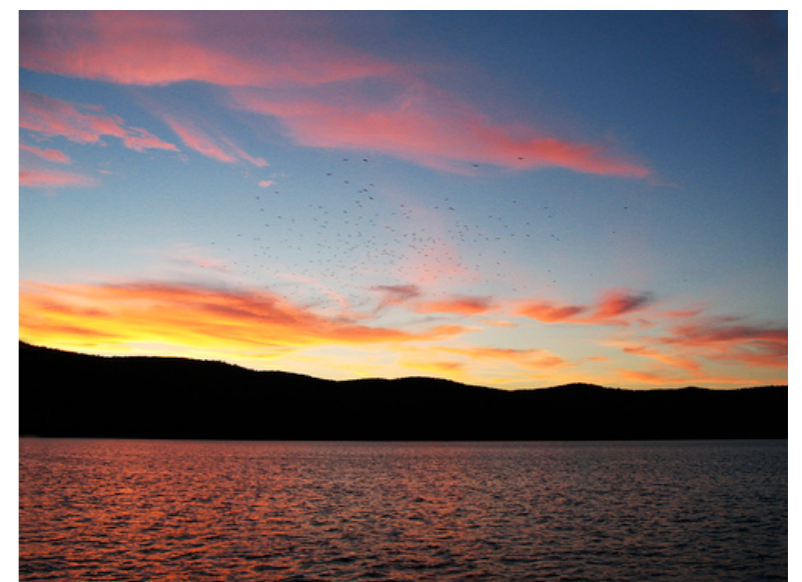

Is there a duck in the image?

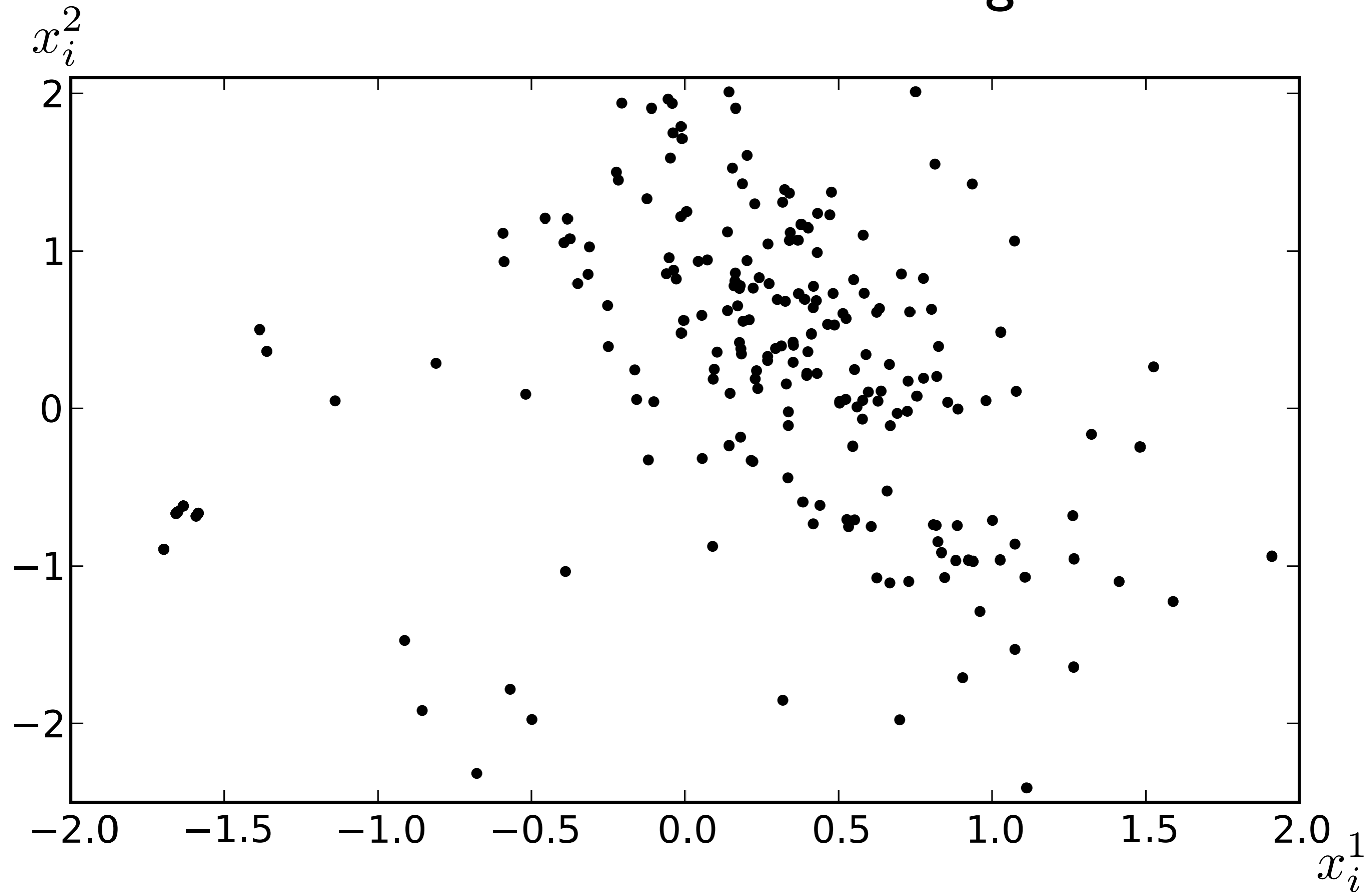

Is there a duck in the image?

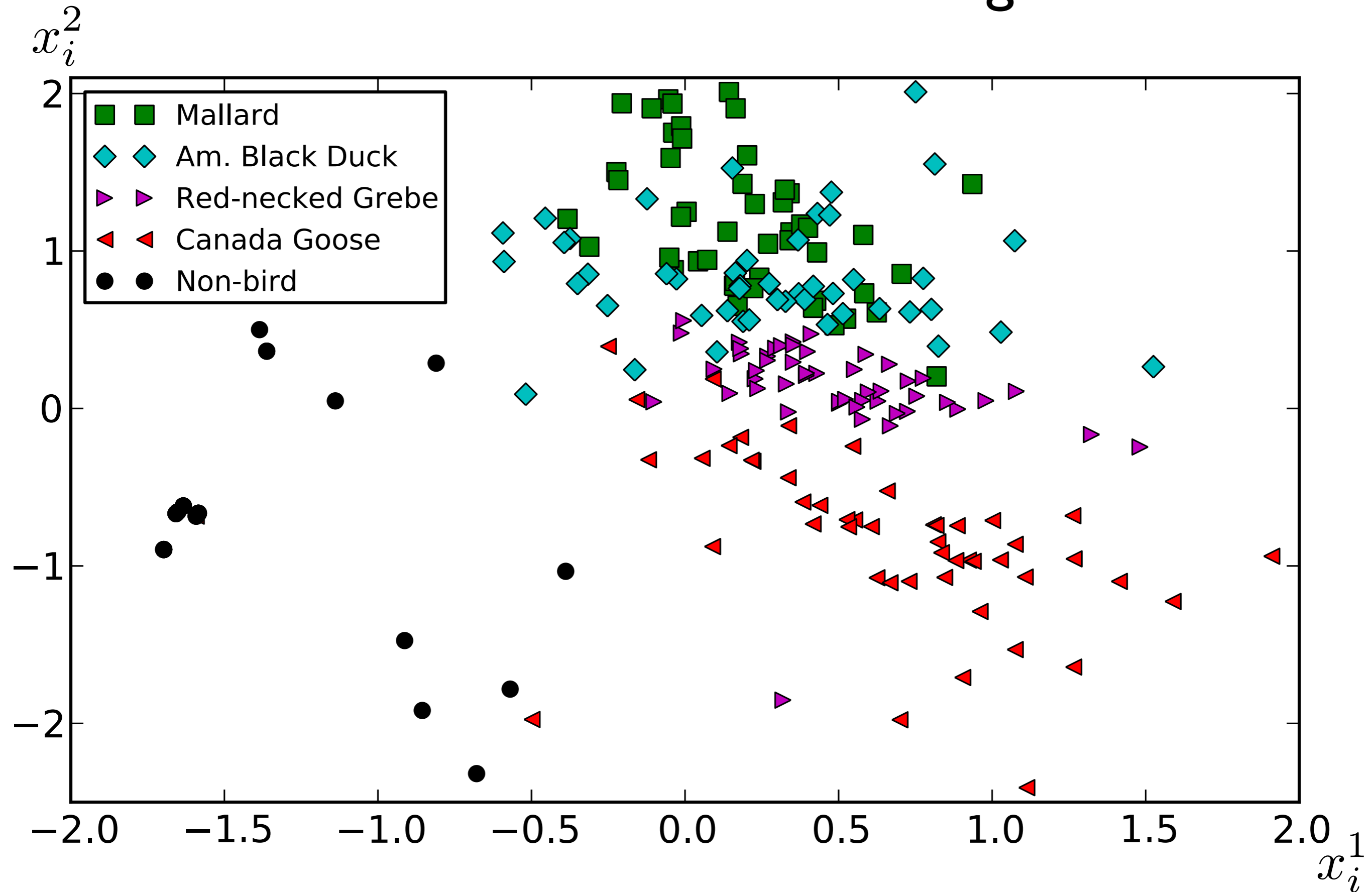

Is there a duck in the image?

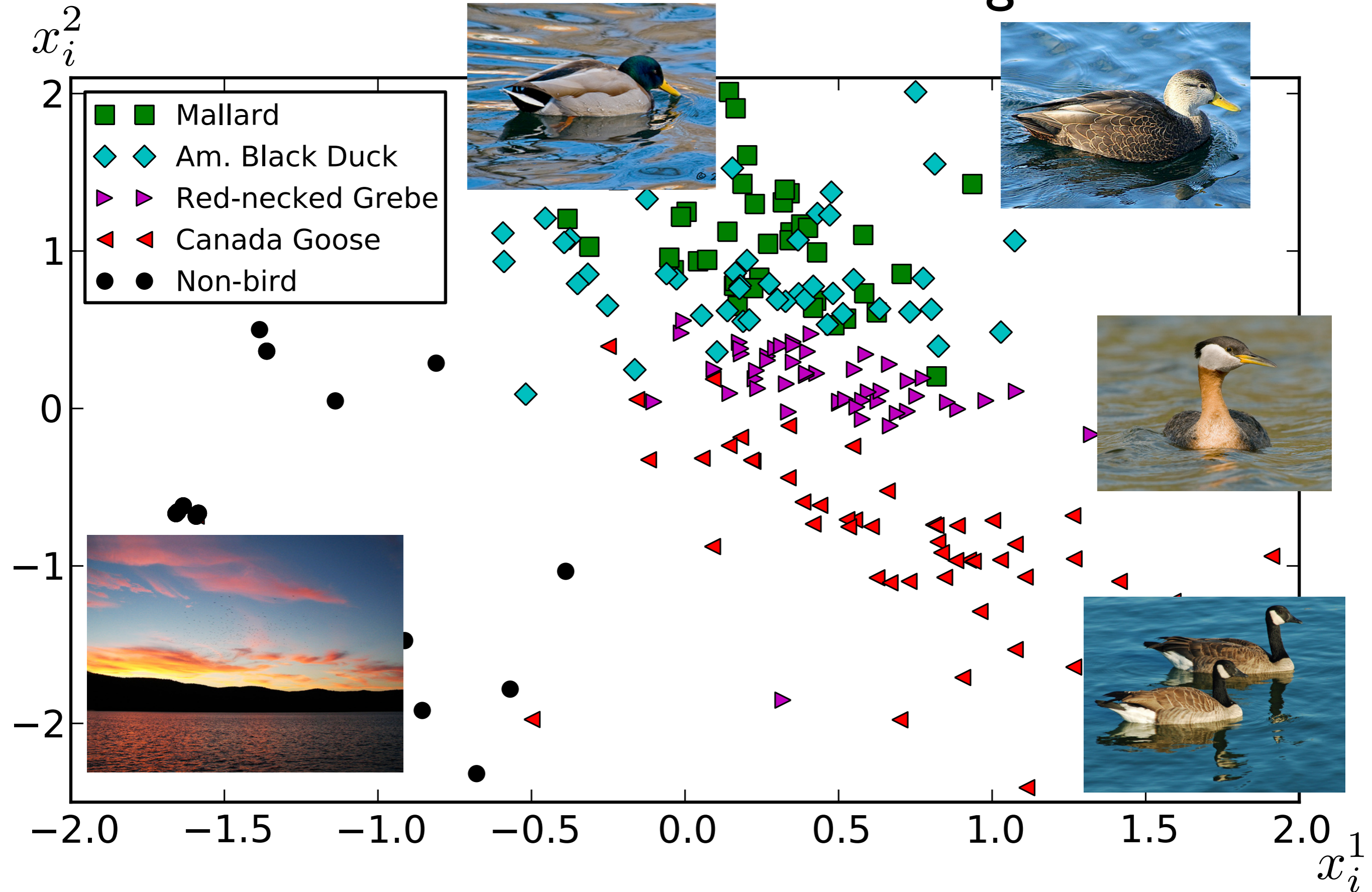

Is there a duck in the image?

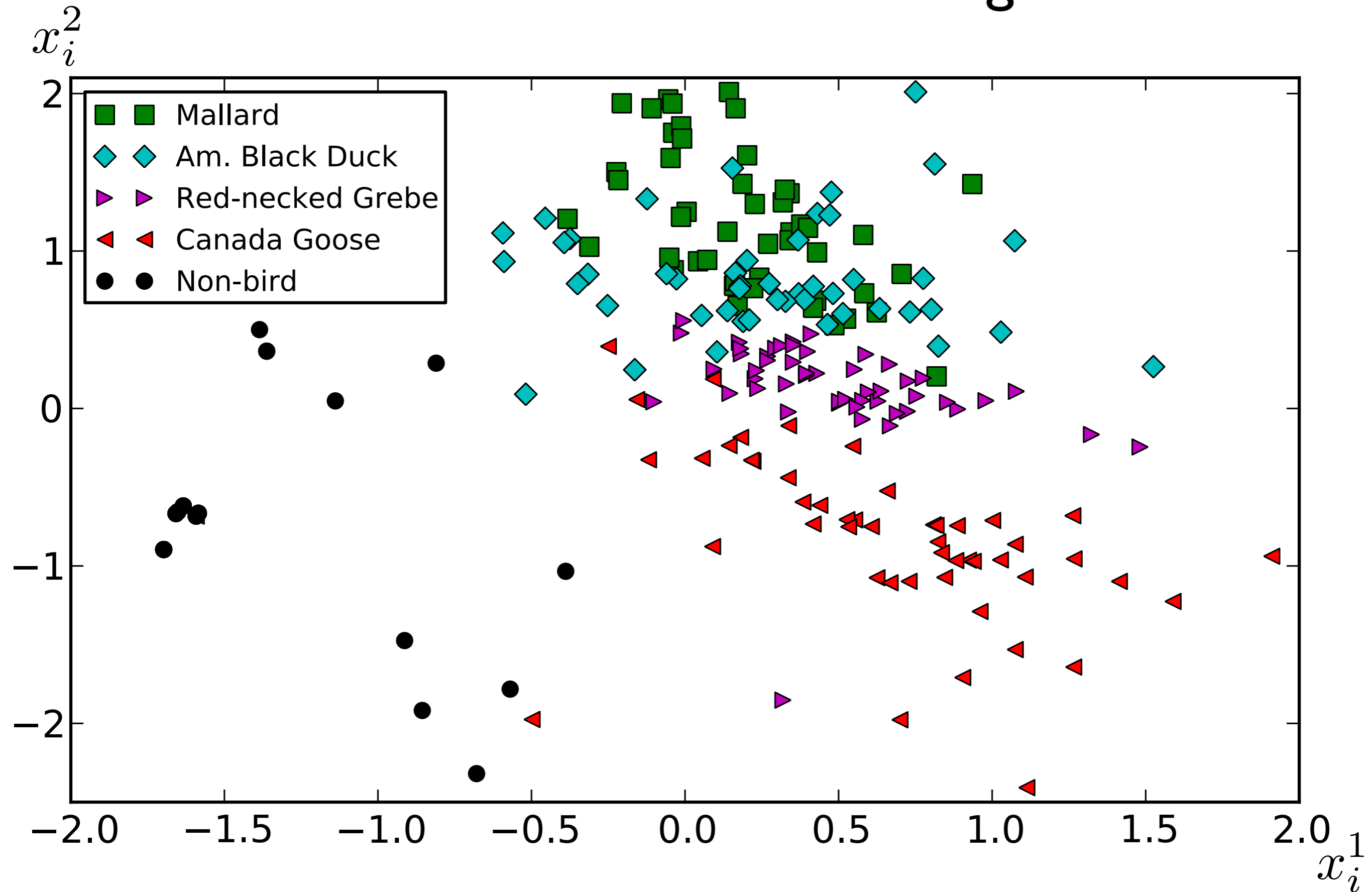

Is there a duck in the image?

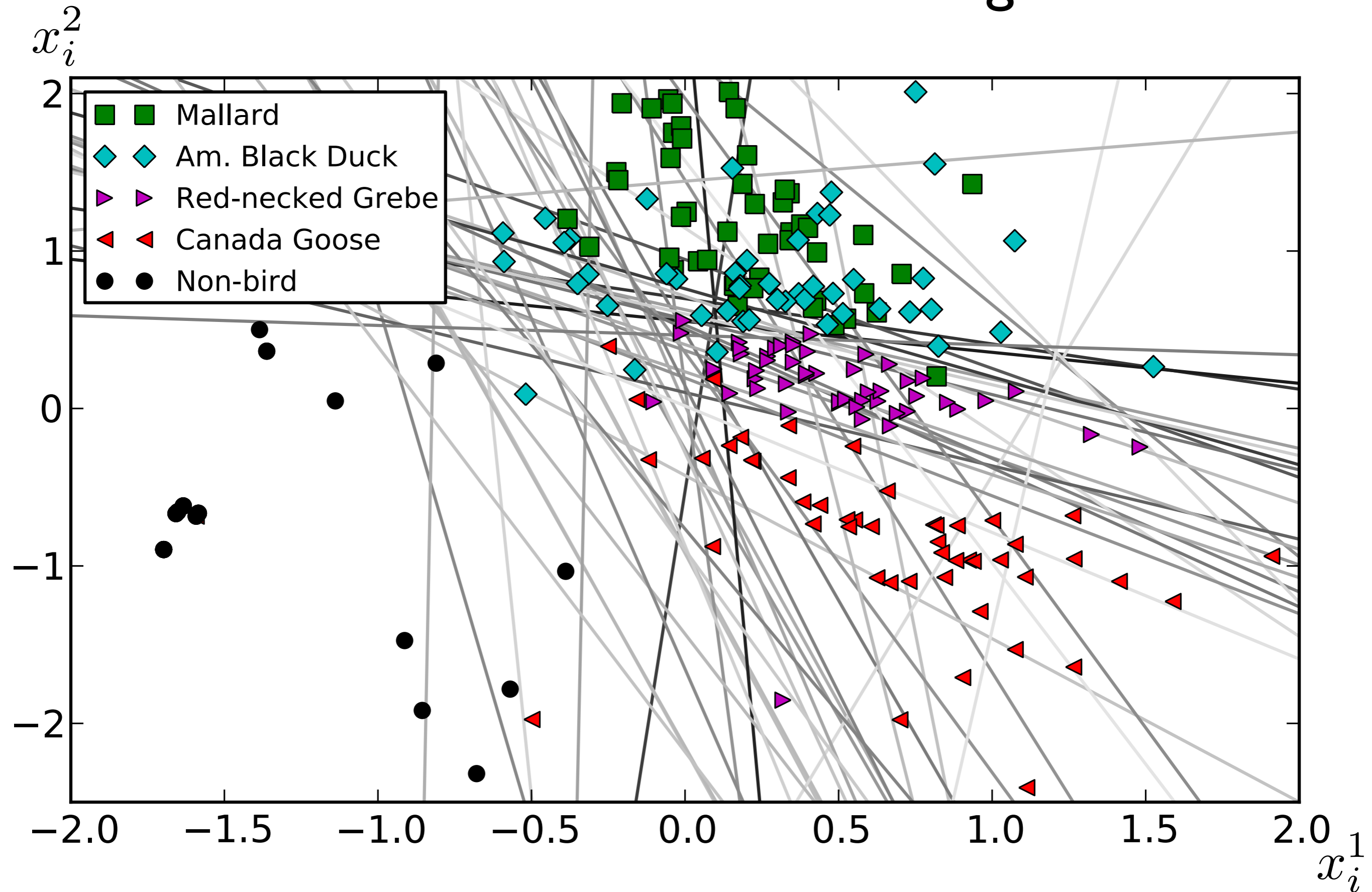

Is there a duck in the image?

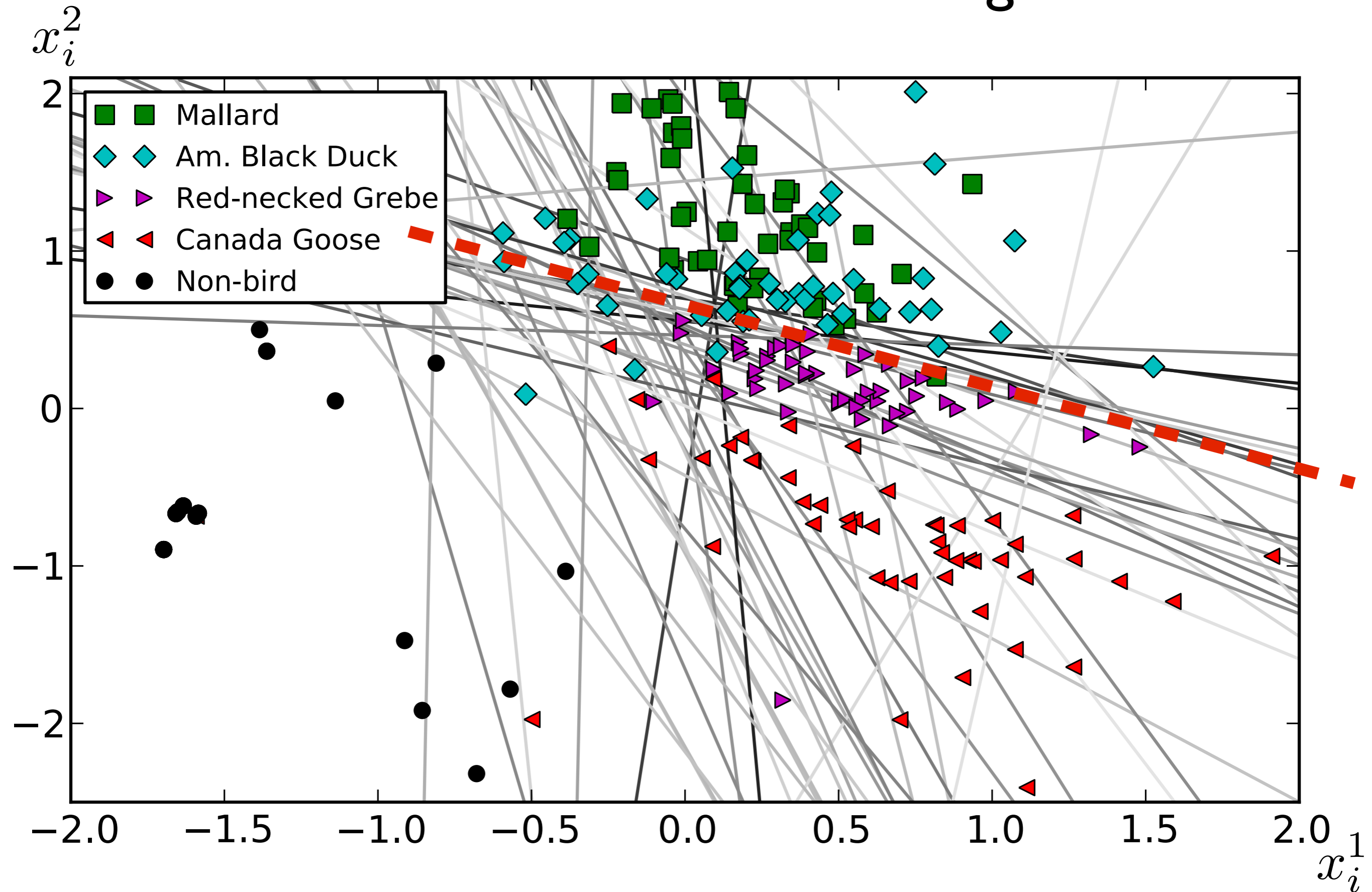

Is there a duck in the image?

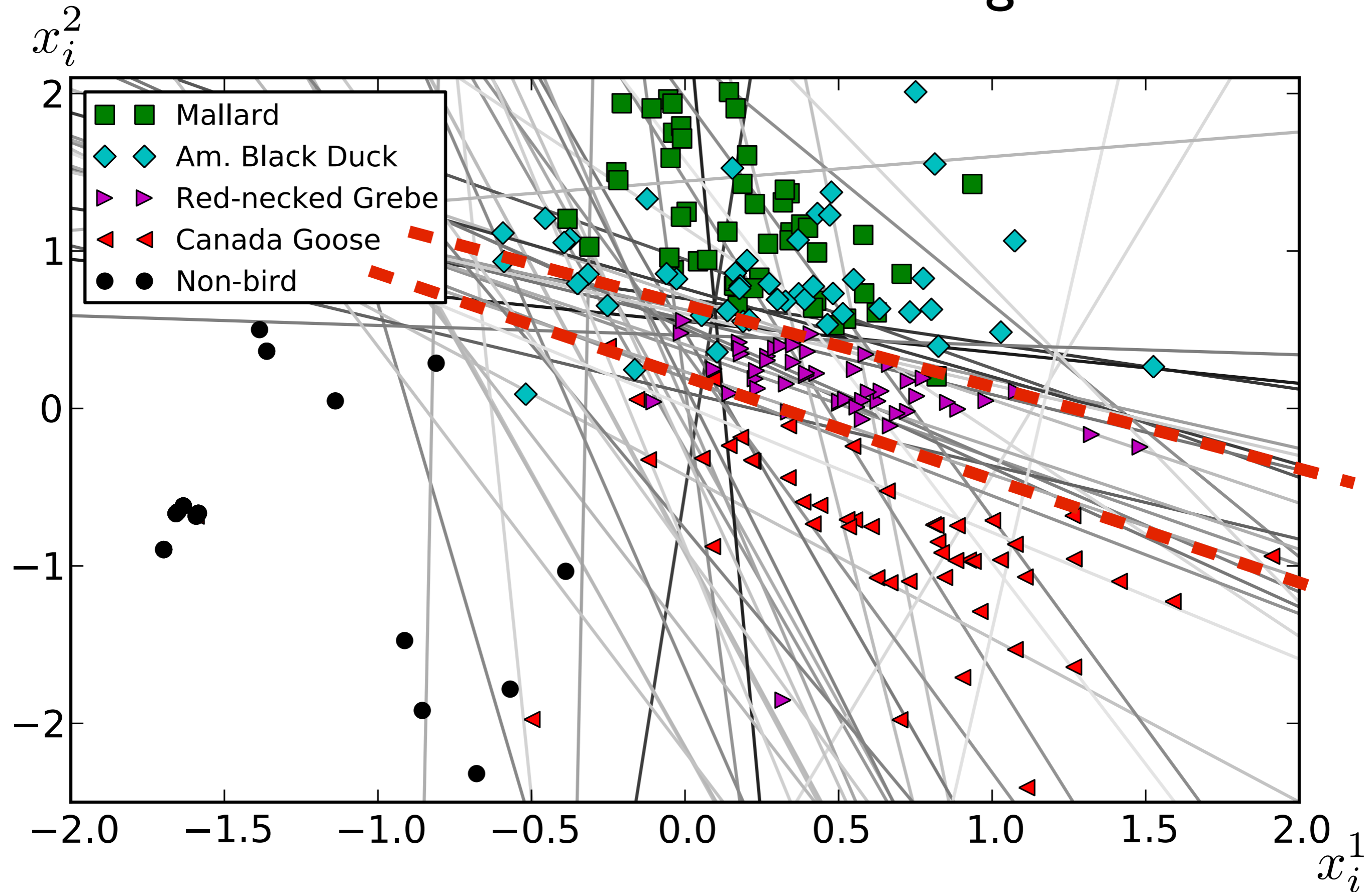

Is there a duck in the image?

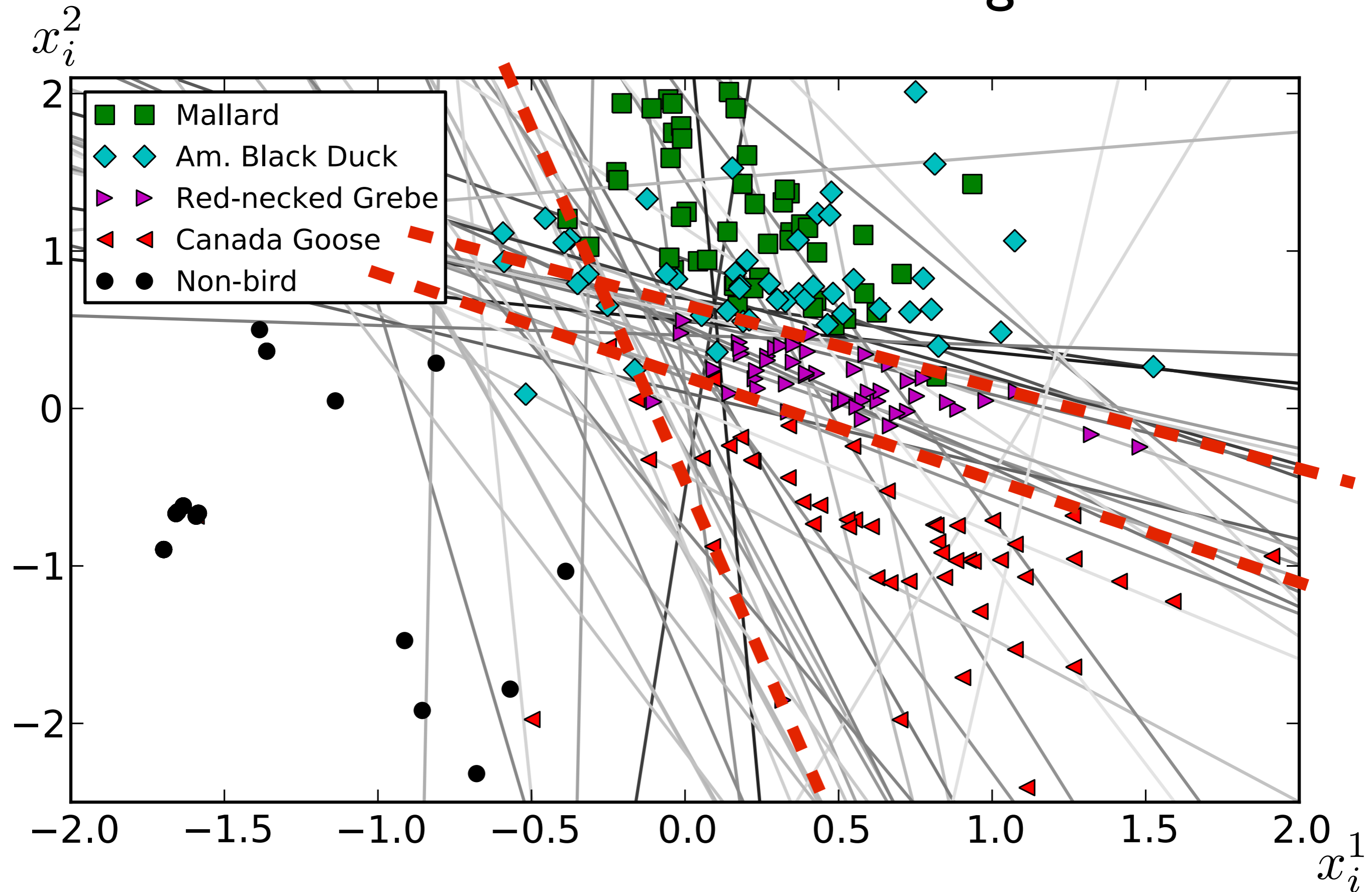

Summary

- Estimate reliable labels
 - Annotator competence and optimism
 - Annotator expertise
 - Image ambiguity/difficulty
-
- Image grouping
 - Schools of thought

thank you

learn more at poster W33