



Social Mexica

# A computer model for social norms in narratives

Iván Guerrero Román

Rafael Pérez y Pérez

When nobody noticed it, Artist mugged Priest. Artist broke Mexica's will with his action against Priest. Now Artist will have to face his fate. Priest -after consulting a Shaman- decided to exile Artist.

Meanwhile Artist decided to start a search for Priest. After hard work and difficult moments Artist could finally find Priest. In a fast movement, Priest wounded Artist. An intense hemorrhage arose which weakened Artist. Slave realised Priest wounded Artist. Slave, knowing that Artist's life was at risk, did not to cure Artist. In this way, Slave expected Artist's dead. Slave's impulsive behavior against Artist was perceived by the Mexicas as an improper act. Slave was challenging his destiny.

Artist threw some dust in Slave's face. Then, using a dagger Artist perforated Slave's chest. Imitating the Sacred Ceremony of the Sacrifice, Artist took Slave's heart with one hand and raised it towards the sun as a sign of respect to the Gods. Artist broke Mexica's will with his action against Slave. Now Artist will have to face his fate. Artist believed that Quetzalcoatl (the feathered-snake) had selected Artist to die. Thus, Artist killed himself.

The background of the slide features a light beige, textured surface, possibly a map or a document. In the top-left corner, there is a partial view of a compass rose with numbers like '091' and '07'. Faint lines and text are visible on the map, including '091 07' and 'THE TABLE'.

**1. Social norms in narratives**

**2. Computational model**

**3. Preliminary results**



# Social norms in narratives

The background of the slide is a light-colored, textured surface, possibly a map or a piece of paper. In the top left corner, there is a circular compass rose with numbers like '090' and '070' visible. The overall tone is warm and yellowish.

What is a social norm?

# What is a social norm?

- A social norm is a generalized expected behavior with social relevance for a social group, and its rupture origins a sanction.

Durkheim, E. (1895). Rules of the sociological method

Sherif, M. (1936). The psychology of social norms

Myers, (1995): Social psychology

Goffman, E. (1979): Relaciones en público

# What is a social norm?

- A social norm is a generalized expected behavior with social relevance for a social group, and its rupture origins a sanction.
  - Generalized expected behavior
  - Social relevance
  - Social group
  - Rupture of a social norm
  - Sanction

Durkheim, E. (1895). Rules of the sociological method

Sherif, M. (1936). The psychology of social norms

Myers, (1995): Social psychology

Goffman, E. (1979): Relaciones en público

# What is a social norm?

- A social norm is a generalized expected behavior with social relevance within a social group, and its rupture origins a sanction.
  - **Generalized expected behavior**
  - Social relevance
  - Social group
  - Rupture of a social norm
  - Sanction

**Expected behaviors:** Allows us to make predictions.

- **Generalized:** Expectations agreed by a group of characters.





# What is a social norm?

- A social norm is a generalized expected behavior with social relevance within a social group, and its rupture origins a sanction.
  - Generalized expected behavior
  - **Social relevance**
  - Social group
  - Rupture of a social norm
  - Sanction



An action is considered socially relevant when it affects or influences the behavior of others.

# What is a social norm?

- A social norm is a generalized expected behavior with social relevance within a social group, and its rupture origins a sanction.
  - Generalized expected behavior
  - Social relevance
  - **Social group**
  - Rupture of a social norm
  - Sanction

**Social group:** Set of characters which interact between them and can be recognized as a distinct unit.



# What is a social norm?

- A social norm is a generalized expected behavior with social relevance within a social group, and its rupture origins a sanction.
  - Generalized expected behavior
  - Social relevance
  - Social group
  - **Rupture of a social norm**
  - Sanction

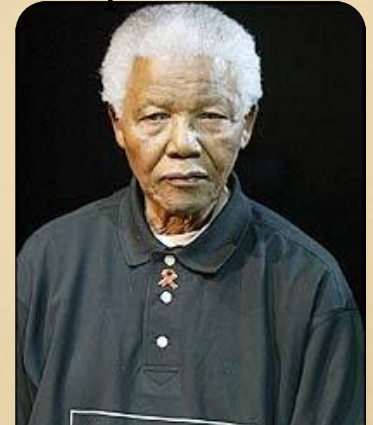

## Occurs when exists:

- An unjustified breach of an expected behavior.
- A breach of the conditions to which a norm applies in a given situation.

# What is a social norm?

- A social norm is a generalized expected behavior with social relevance within a social group, and its rupture origins a sanction.
  - Generalized expected behavior
  - Social relevance
  - Social group
  - Rupture of a social norm
  - **Sanction**



**Social sanctions:** Reaction by members of a group indicating disapproval of a conduct.

- Disapproving look
- Discrimination
- Indifference



# Social norms in narratives

- **Hypothesis**

- The rupture of a social norm can generate more interesting and novel narratives. Nevertheless, a system that consistently breaks social norm can produce incoherent and non-interesting narratives.



# Computer model for social norms in narratives

Social Mexica

# Computer model for social norms in narratives

## 1. Hierarchical model

Elements to represent relations between characters

## 2. Social norms model

Components employed to identify, represent and employ social norms during the plot generation process.

## 3. Narrative model

Elements to represent a narrative.



# Hierarchical model

Computer model for social norms in  
narratives



# Computer model for social norms in narratives

- **Character's hierarchical model**

- Components

- Character's set
- Hierarchy: Group of characters with common attributes, values or beliefs.



Tlatoani, Priest

Prince, Princess

EK, JK, Warrior

F, Fs, H, L, V, Tr, A

Slave, Enemy

# Computer model for social norms in narratives

- **Basic hierarchies**

- **Social hierarchy:** Identifies the different social levels for the character's set.
- **Gender hierarchy:** Identifies the gender to which every character belongs to.

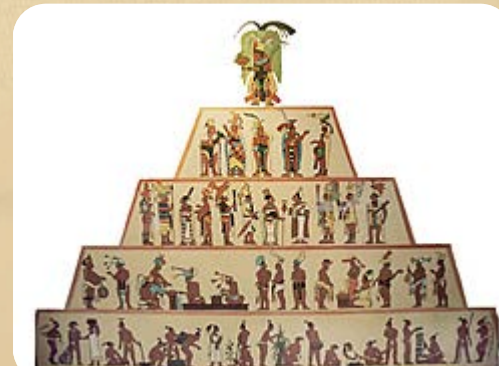
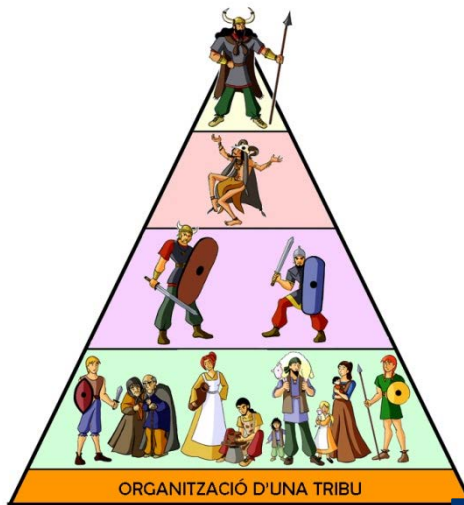



# Social norms' model

Computer model for social norms in  
narratives

# Computer model for social norms in narratives

## **Social norms' model**

- Goals
  - To **represent** the social knowledge.
  - To **identify** the rupture of social norms.
  - To **employ** the social knowledge inside the narrative generation process.



Computer model for social norms in narratives

- Hierarchical model
- **Social norms model**
- Narrative model

# REPRESENTATION OF SOCIAL NORMS

# Representation of social norms

- The knowledge structures proposed by the model employ the same notation developed for MEXICA.
  - Emotional relations are relevant to represent social knowledge.
  - The research is focused on narrative generation.
- Narratives
  - Sequences of simple actions
    - Character + action description + Character
- Narrow contexts
  - Context: Set of emotional relations between the characters of a story.

# Representation of social norms

- **Social relations**

- Represent the emergence of social ruptures with emotions and tensions.

- **Types**

- **Emotion:** Represent affective reactions between characters due to an action with social repercussion.
    - **Tension:** Hostile state or conflict between characters due to an action with social repercussion.

# Representation of social norms

- **Social relations**

- Represent the emergence of social ruptures with emotions and tensions.

- **Types**

- **Emotion:** Represent affective reactions between characters due to an action with social repercussion.
- **Tension:** Hostile state or conflict between characters due to an action with social repercussion.

JK socially rejects E





# Representation of social norms

- **Social relations**

- Represent the emergence of social ruptures with emotions and tensions.

- **Types**

- **Emotion:** Represent affective reactions between characters due to an action with social repercussion.
- **Tension:** Hostile state or conflict between characters due to an action with social repercussion.

E disobeyed the authorities according to JK

JK socially rejects E

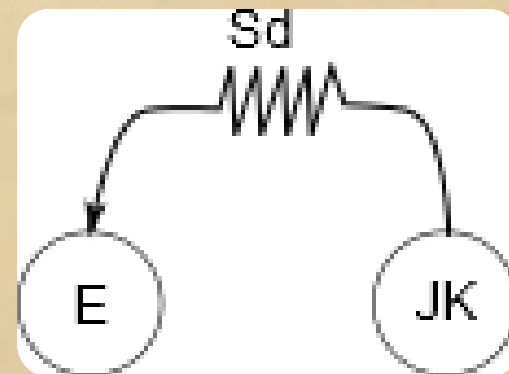

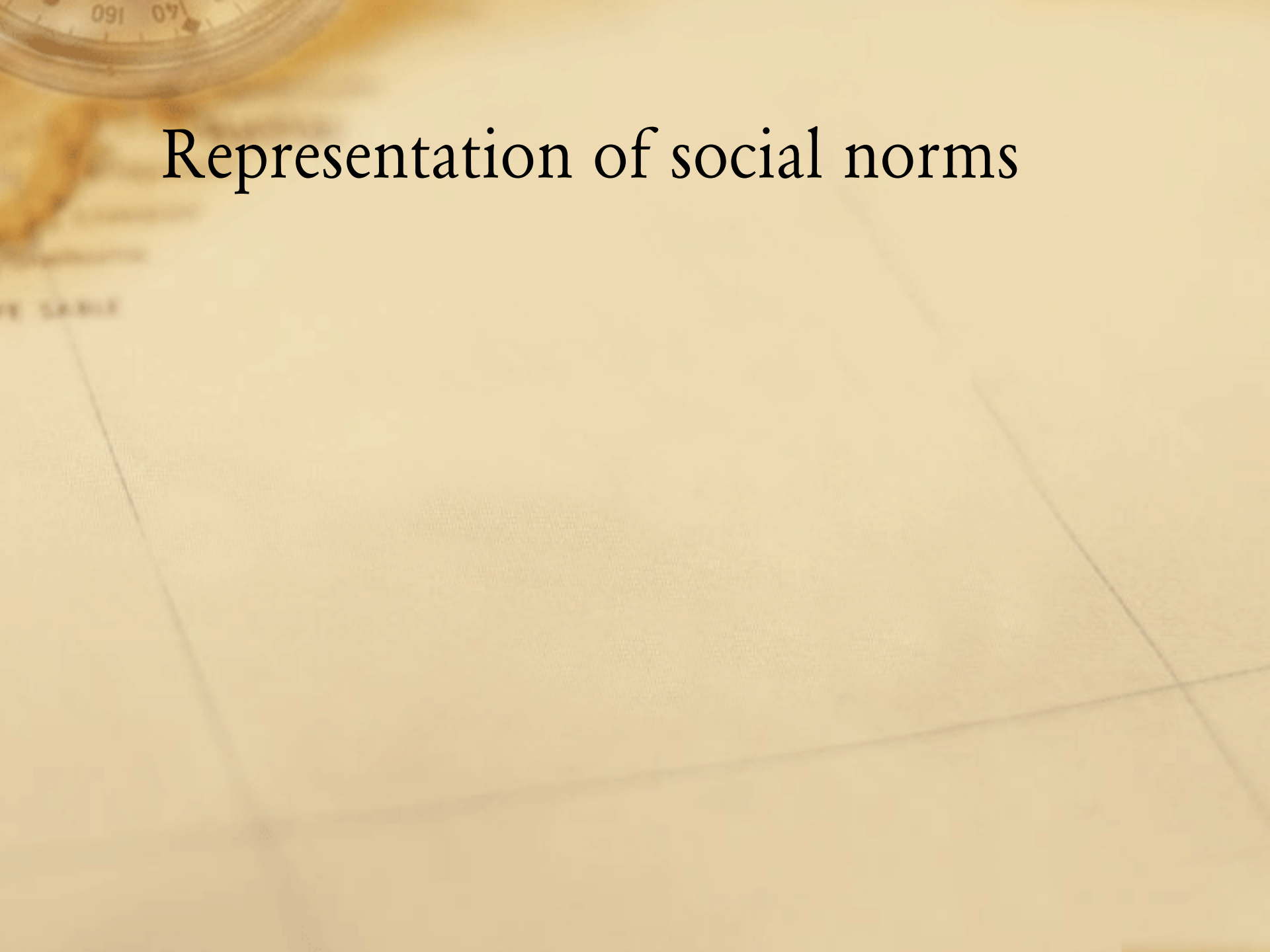
The background of the slide is a warm, yellowish-tan color. In the top-left corner, there is a partial view of a compass rose with numbers like '091' and '071'. Below it, there are faint, illegible lines of text and a grid pattern, suggesting a map or a technical drawing. The main text is centered in the upper half of the image.

# Representation of social norms

# Representation of social norms

## Attributes of social relations

### – Emotion

- Type: Social acceptance
- Valence (Positive, negative)
- Intensity: Integer value

JK socially rejects to E



# Representation of social norms

## Attributes of social relations

### – Emotion

- Type: Social acceptance
- Valence (Positive, negative)
- Intensity: Integer value

### – Tension

- Type: Social disobedience, burden, threat, clashing emotions
- State (activate, deactivate )

E disobeyed the authorities according to JK

JK socially rejects to E

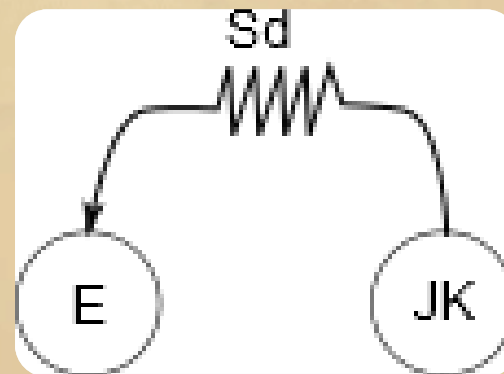

# Representation of social norms

- **Contexts**

- Set of relations between the characters inside the story world.

- **Stories**

- Sequence of simple actions.

# Representation of social norms

- **Contexts**

- Set of relations between the characters inside the story world.

- **Stories**

- Sequence of simple actions.



The enemy hated the jaguar knight.

# Representation of social norms

- **Contexts**

- Set of relations between the characters inside the story world.

- **Stories**

- Sequence of simple actions.

The enemy hated the jaguar knight.

The enemy attacked the jaguar knight.

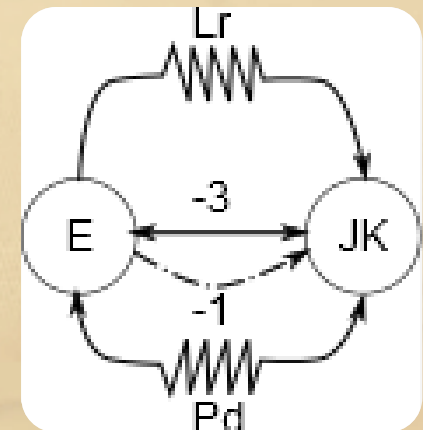

# Representation of social norms

- **Contexts**

- Set of relations between the characters inside the story world.

- **Stories**

- Sequence of simple actions.

The enemy hated the jaguar knight.

The enemy attacked the jaguar knight.

The jaguar knight ran away from the enemy.

...

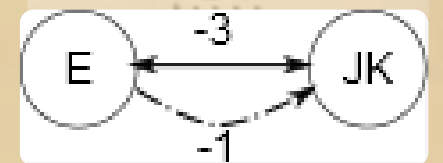
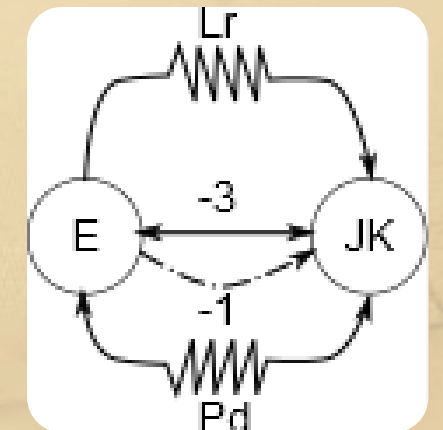





Computer model for social norms in narratives

- Hierarchical model
- **Social norms model**
- Narrative model

# **DETECTING SOCIAL NORM VIOLATIONS**

# Social norm violation

## **Processes**

1. A social norm is broken when an unjustified threat to the welfare of a social group is identified.

# Social norm violation

## **Processes**

1. A social norm is broken when an unjustified threat to the welfare of a social group is identified.
  - Threat to the welfare
    - When a tension with social effects is added to the story context.

# Social norm violation

## Processes

1. A social norm is broken when an unjustified threat to the welfare of a social group is identified.
  - Threat to the welfare
    - When a tension with social effects is added to the story context.
  - Justified action
    - Inside a story, an action that threatens the welfare is justified when:
      - Another tension was triggered against the action performer
      - Another tension was triggered against a positively-linked character to the action performer.



# Social norm violation

## **Example**

# Social norm violation

## Example

The princess was sister of the prince.

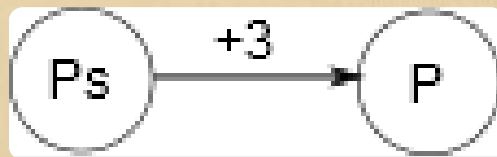

# Social norm violation

## Example

The princess was sister of the prince.

The trader hated the prince.

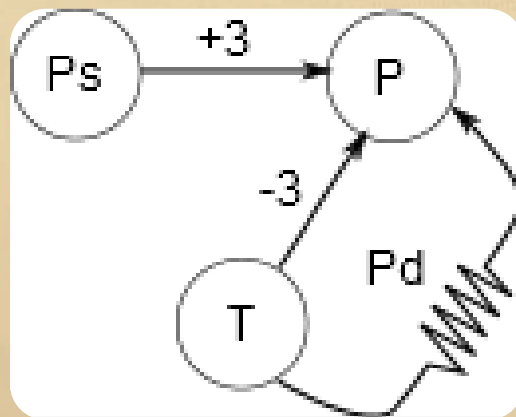

# Social norm violation

## Example

The princess was sister of the prince.

The trader hated the prince.

The trader attacked the prince.

**Breaks SN**

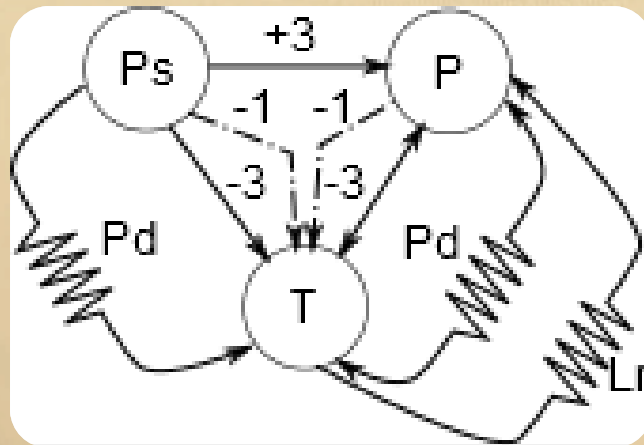



# Social norm violation

## Example

The princess was sister of the prince.

The trader hated the prince.

The trader attacked the prince.

The princess attacked the trader.

**Breaks SN**

**Justified**

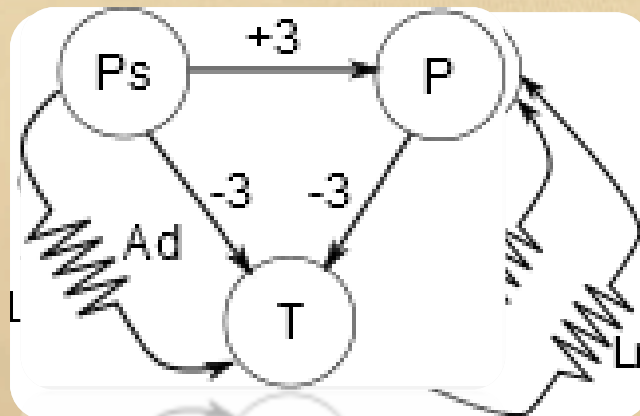

# Social norm violation

## Example

The princess was sister of the prince.

The trader hated the prince.

The trader attacked the prince.

The princess attacked the trader.

**Breaks SN**

**Justified**

The background of the slide features a warm, yellowish-tan color with a subtle texture. In the top-left corner, there is a partial view of a compass rose with numbers like '091' and '07'. Below it, faint lines and text from a map are visible, including the words 'THE CANALS' and 'THE CANALS'.

# Social norm violation

Durkheim, (2001):The elementary forms of religious life.

Habermas, (1981): Theory of the communicative action

# Social norm violation

## **Processes**

Durkheim, (2001):The elementary forms of religious life.

Habermas, (1981): Theory of the communicative action

# Social norm violation

## **Processes**

2. A social norm is broken when the elements of a previously detected situation where a social rupture occurred, are identified.

Durkheim, (2001):The elementary forms of religious life.

Habermas, (1981): Theory of the communicative action

# Social norm violation

## Processes

2. A social norm is broken when the elements of a previously detected situation where a social rupture occurred, are identified.

## Mechanism

1. Compare the story context after an action has been added, with the contexts where the rupture of a social norm was identified.
2. If a similar context is detected, the same sanction that was applied on the previous case is also applied to the new instance.

Durkheim, (2001):The elementary forms of religious life.

Habermas, (1981): Theory of the communicative action

# Social norm violation

- **Social action**

- Actions employed to emphasize the presence of a socially relevant action inside a story.
- Attributes:
  - Name
  - Characters
  - Post condition
  - Socially relevant elements
    - Characters
    - Relations between characters
  - Textual representation

The background of the slide is a light beige or cream color, featuring a faint, large-scale grid pattern. In the upper-left corner, there is a partial view of a compass rose with some numbers like '091' and '071' visible. The text 'Social norm violation' is centered in the upper half of the slide in a black, serif font.

# Social norm violation





# Social norm violation

**Construction of social contextual  
structures**

# Social norm violation

**Construction of social contextual structures**

**Example**

# Social norm violation

## Construction of social contextual structures

### Example

The enemy hated the jaguar knight.



# Social norm violation

## Construction of social contextual structures

### Example

The enemy hated the jaguar knight.

The enemy attacked the jaguar knight.

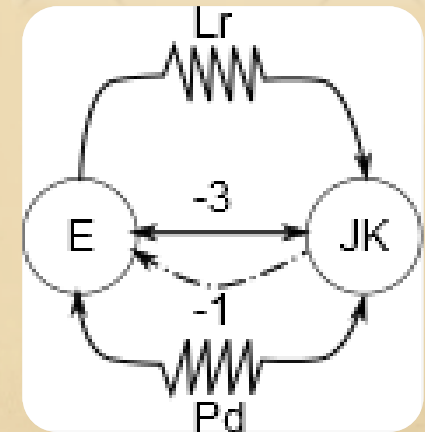

# Social norm violation

## Construction of social contextual structures

### Example

The enemy hated the jaguar knight.

The enemy attacked the jaguar knight.

The jaguar knight ran away from the enemy.

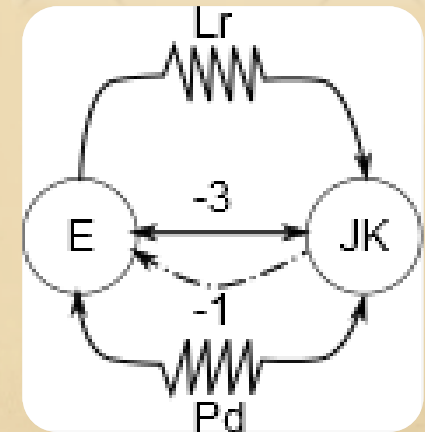

# Social norm violation

## Construction of social contextual structures

### Example

The enemy hated the jaguar knight.

The enemy attacked the jaguar knight.

The jaguar knight ran away from the enemy.

The jaguar knight is a ...

...

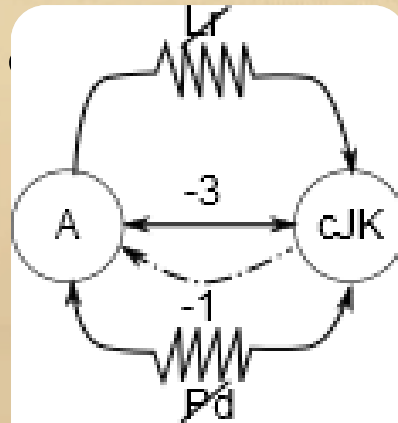
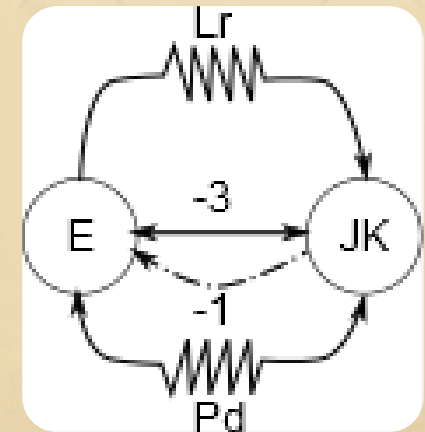

JK location changed

JK location changed

# Social norm violation

## Construction of social contextual structures

### Example

The enemy hated the jaguar knight.

The enemy attacked the jaguar knight.

The jaguar knight ran away from the enemy.

The jaguar knight is a

...

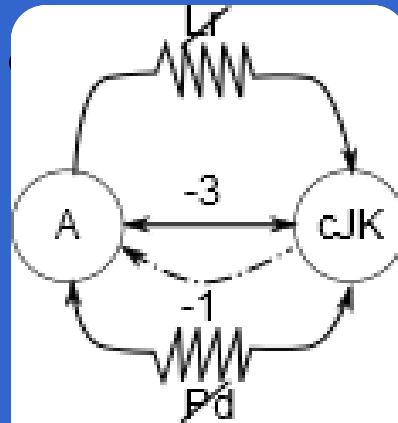
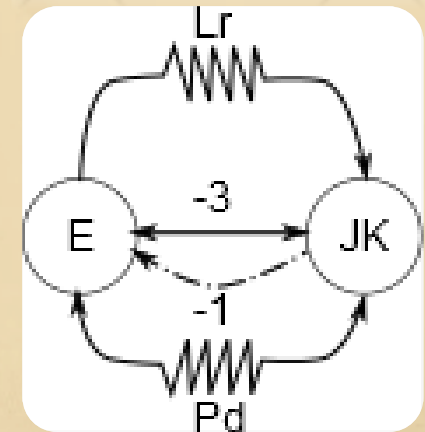

JK location changed

Social contextual structure



# Social norm violation

## **Example**



# Social norm violation

## **Example**

Jaguar knight admired the tlatoani.

The tlatoani went to the Texcoco lake with the jaguar knight.

The tlatoani had an accident.

The hunter found by accident the jaguar knight..

The hunter hated the jaguar knight.

The hunter attacked the jaguar knight.

# Social norm violation

## **Example**

Jaguar knight admired the tlatoani.

The tlatoani went to the Texcoco lake with the jaguar knight.

The tlatoani had an accident.

The hunter found by accident the jaguar knight..

The hunter hated the jaguar knight.

The hunter attacked the jaguar knight.

The jaguar knight ran away from the hunter.

# Social norm violation

## Example

Jaguar knight admired the tlatoani.

The tlatoani went to the Texcoco lake with the jaguar knight

The tlatoani had an accident.

The hunter found by accident the jaguar knight..

The hunter hated the jaguar knight.

The hunter attacked the jaguar knight.

The jaguar knight ran

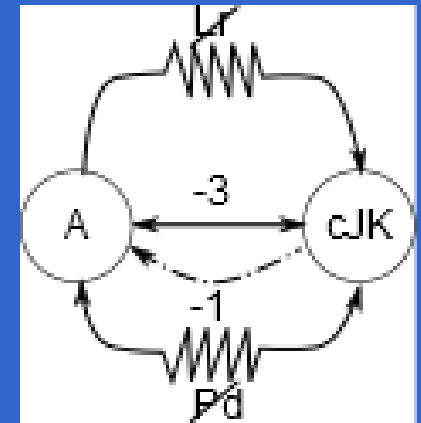

JK location changed

The jaguar knight is a coward fighter.

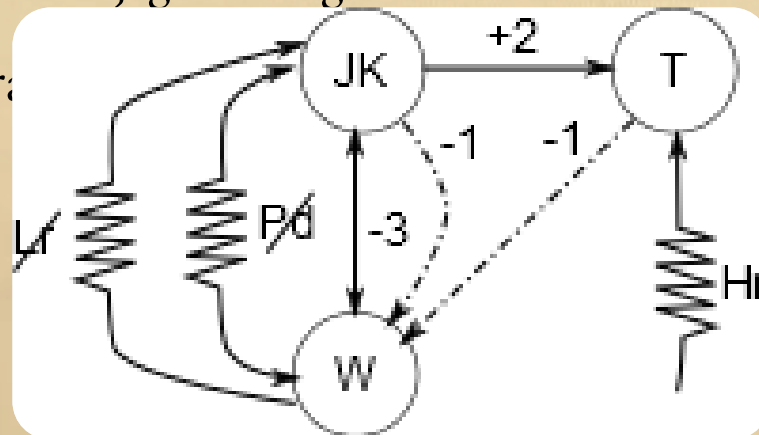

# Social norm violation

## Example

Jaguar knight admired the tlatoani.

The tlatoani went to the Texcoco lake with the jaguar knight

The tlatoani had an accident.

The hunter found by accident the jaguar knight..

The hunter hated the jaguar knight.

The hunter attacked

The jaguar knight ran

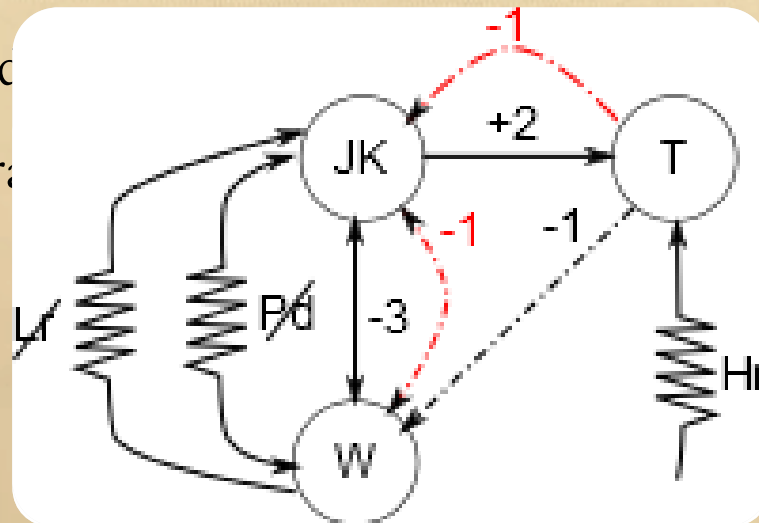
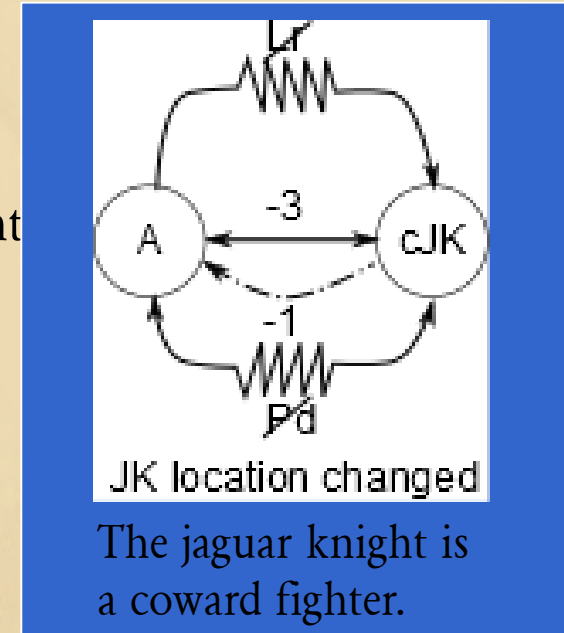

The background of the slide features a faded, sepia-toned map with a compass rose in the upper left corner. The map shows some geographical outlines and text, though it is out of focus. The compass rose has numbers like '091' and '07' visible.

## Computer model for social norms in narratives

- Hierarchical model
- **Social norms model**
- Narrative model

# **RELEVANCE OF SOCIAL NORMS**

# Relevance of social norms

- Social communication
  - The model provides a useful tool to study aspects of the communication theory.
- Validation of the hypothesis
  - Relationship between the interestingness of a story and the social norms.
- Narrative generation process
  - Social knowledge employed to improve the character and action instantiation processes.
- Narrative evaluation process



# Preliminary results

# Preliminary results

- We employed a questionnaire to cast light on how the model's implementation serves for:
  - Generating more interesting narratives.
  - Accurately identifying social norm violations.
- 3 stories were presented



# Preliminary results

- We employed a questionnaire to cast light on how the model's implementation serves for:
  - Generating more interesting narratives.
  - Accurately identifying social norm violations.
- 3 stories were presented

The artist went to Texcoco lake with the lady.

The virgin followed the artist.

The virgin admired and respected the artist.

The artist went to Tlatelolco market.

The lady found by accident the artist.

The artist was brother of the lady.

# Preliminary results

- We employed a questionnaire to cast light on how the model's implementation serves for:
  - Generating more interesting narratives.
  - Accurately identifying social norm violations.
- 3 stories were presented

The artist went to Texcoco lake with the lady.  
The virgin followed the artist.  
The virgin admired and respected the artist.  
The artist went to Tlatelolco market.  
The lady found by accident the artist.  
The artist was brother of the lady.

The jaguar knight went hunting with the tlatoani.  
The fisherman hated the tlatoani.  
The fisherman attacked the tlatoani.  
The tlatoani attacked the fisherman.  
The jaguar knight made prisoner the fisherman

# Preliminary results

- We employed a questionnaire to cast light on how the model's implementation serves for:
  - Generating more interesting narratives.
  - Accurately identifying social norm violations.
- 3 stories were presented

The artist went to Texcoco lake with the lady.  
The virgin followed the artist.  
The virgin admired and respected the artist.  
The artist went to Tlatelolco market.  
The lady found by accident the artist.  
The artist was brother of

The jaguar knight went hunting with the tlatoani.  
The fisherman hated the tlatoani.  
The fisherman attacked the tlatoani.  
The tlatoani attacked the fisherman.

The warrior had an accident.  
The tlatoani realized that the warrior had an accident.  
The tlatoani cured the warrior.  
The virgin mugged the tlatoani.  
The warrior killed the virgin.  
The warrior sacrificed himself.

prisoner the fisherman

# Evaluation of interestingness

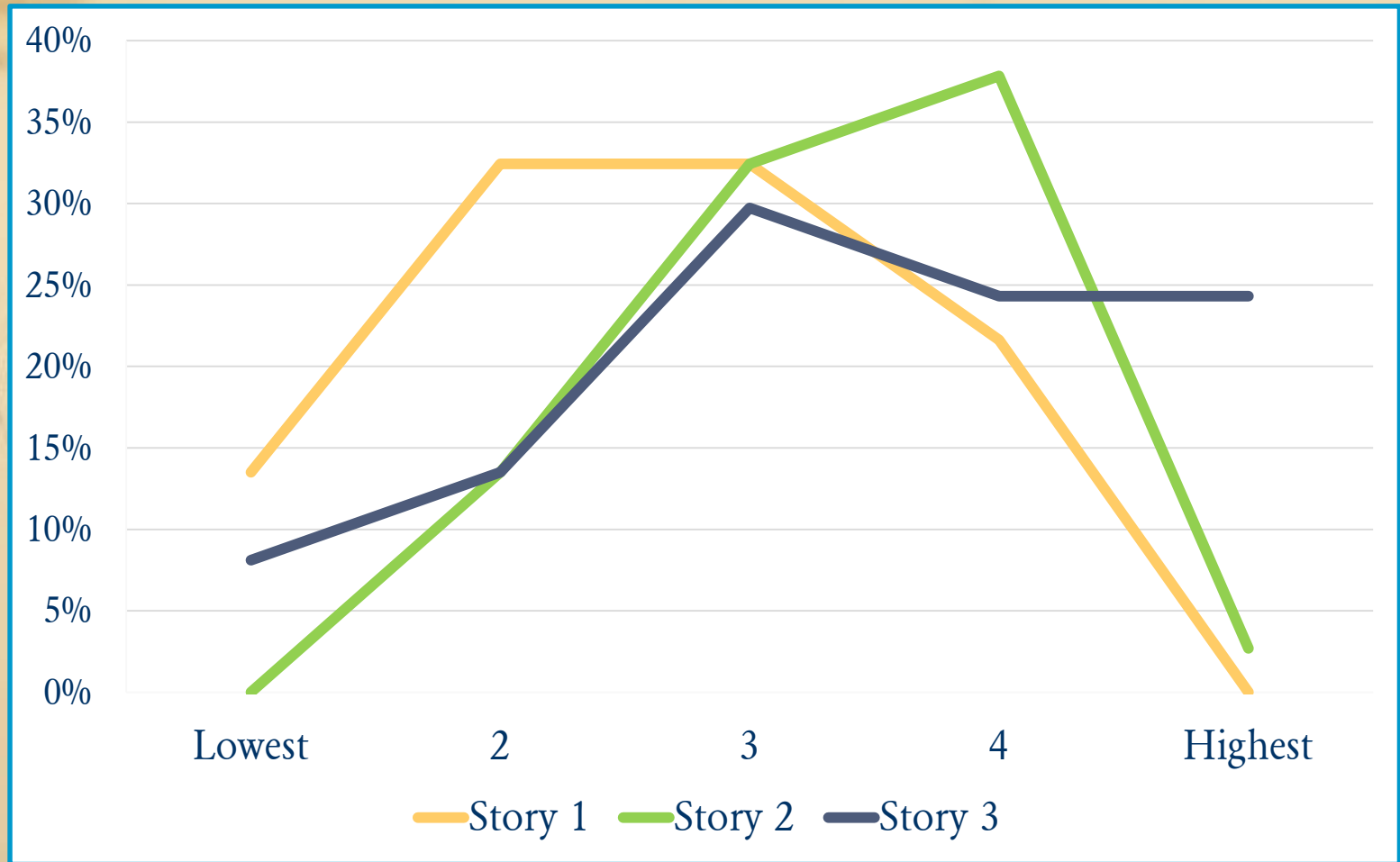

# Evaluation of interestingness

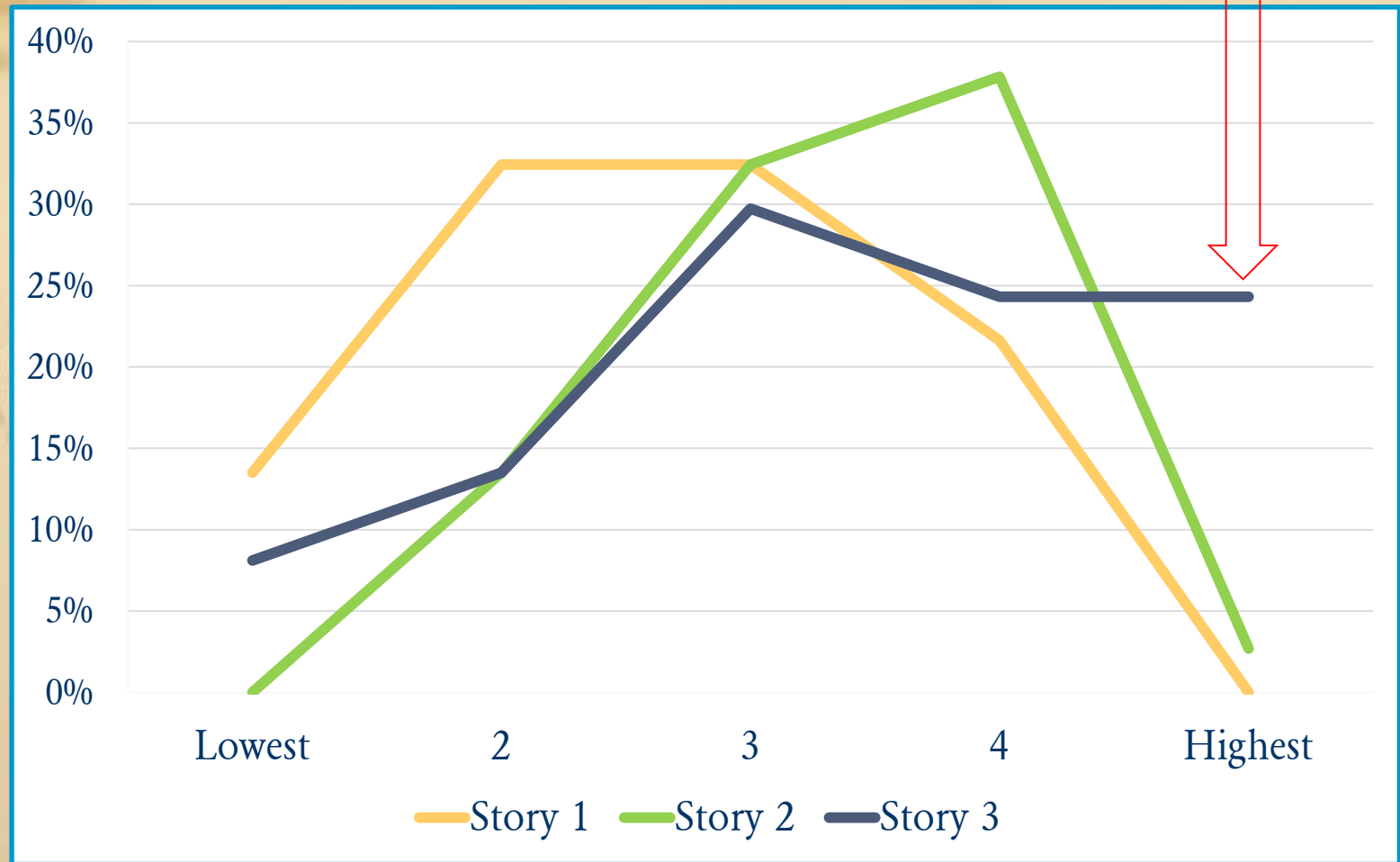

# Rupture of social norms

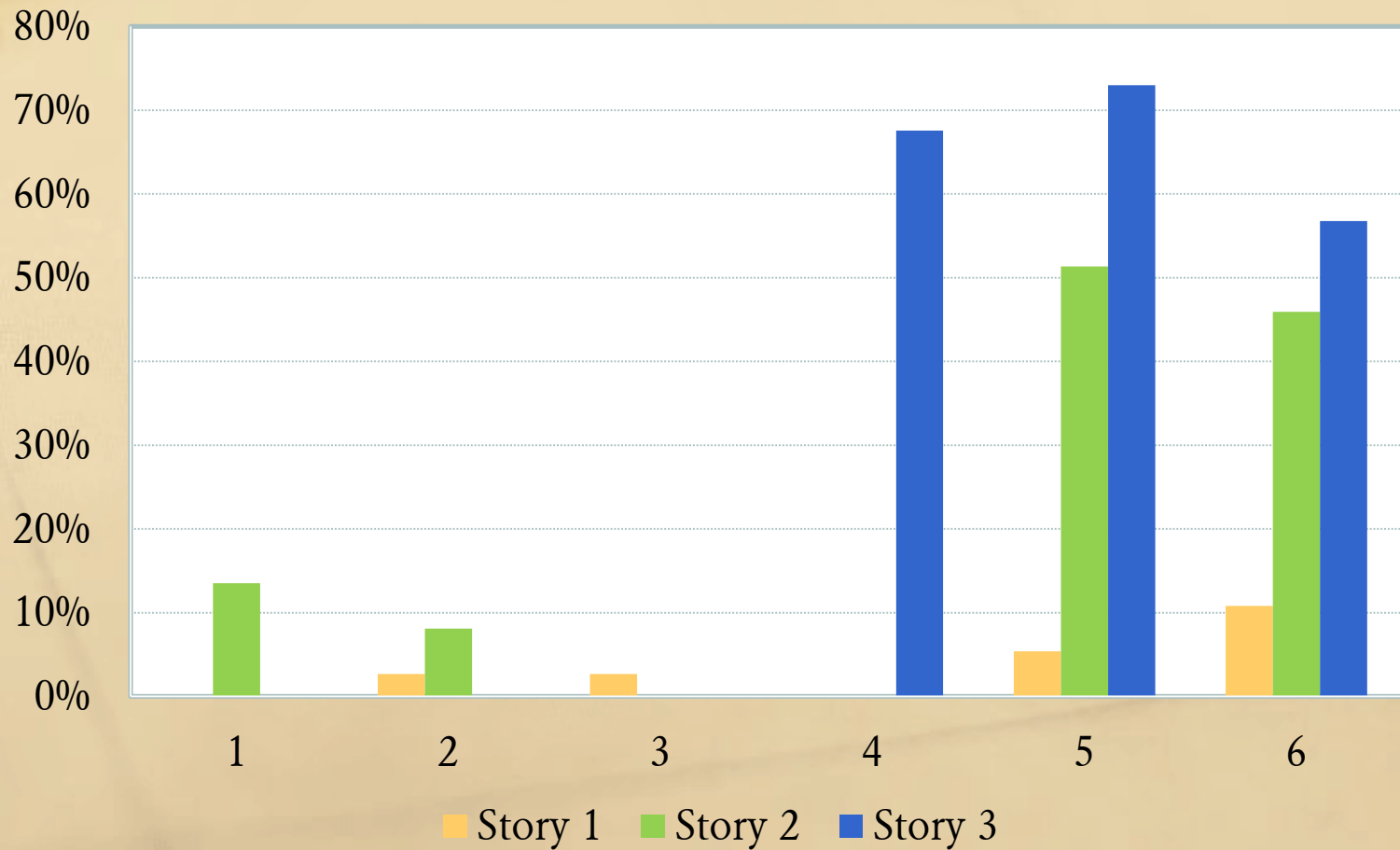

# Summary

- Social norms' model
  - **Represent**
    - Define social emotions and tensions, actions and groups
  - **Identify**
    - (Method 1) Select socially relevant tensions and emotions.
    - (Method 2) Write inspiring stories.
  - **Employ**
    - Character selection methods
    - Action selection methods
    - Story evaluation metrics
    - ...