

Znanost
na cesti

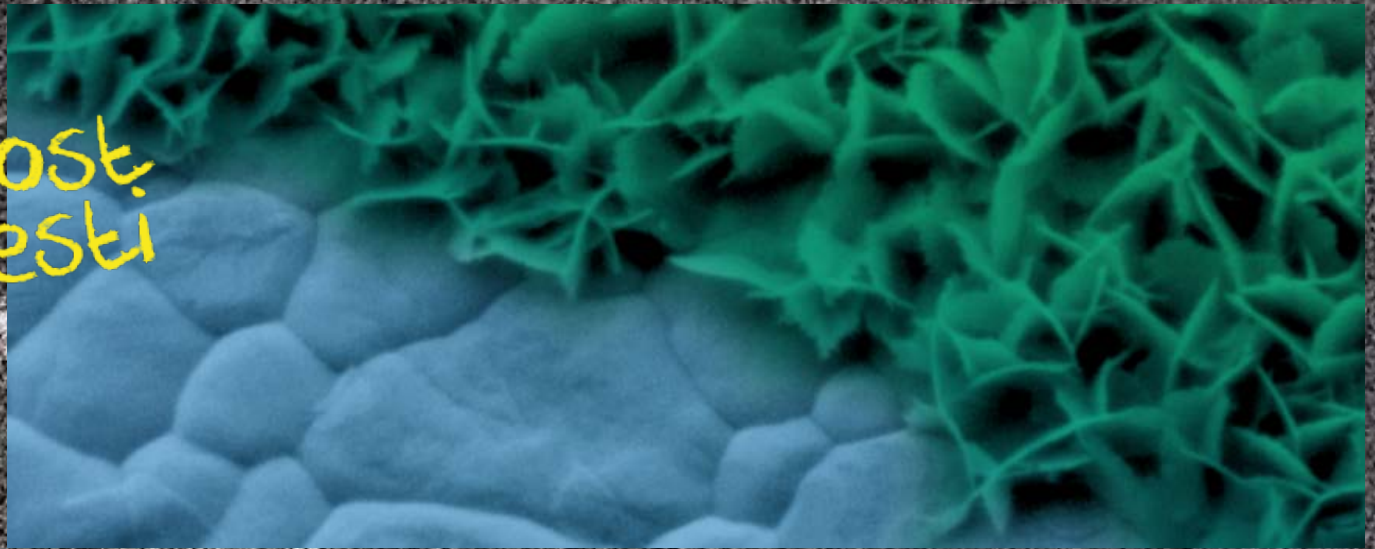

Keramika v času nanotehnologije

dr. Andraž Kocjan, Institut „Jožef Stefan“
Mojca Delač, Radio Slovenija

KERAMIKA

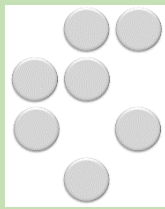

- Anorganski, nekovinski kristalinični in steklasti materiali

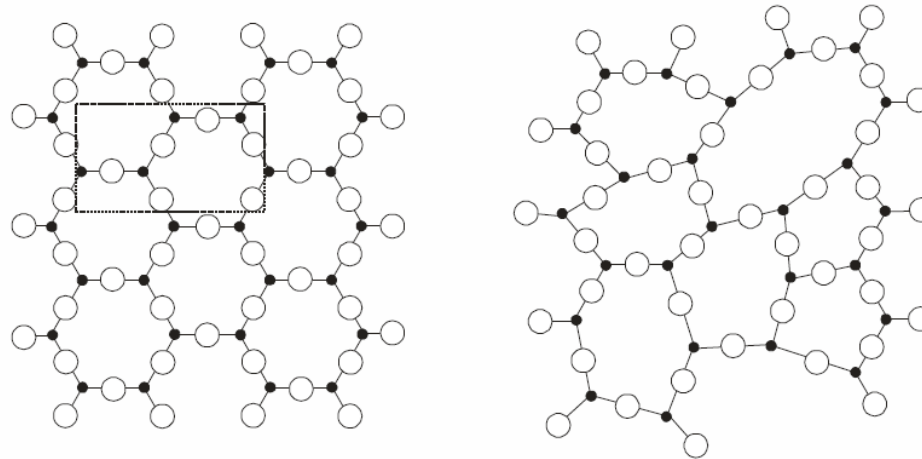

KERAMIKA

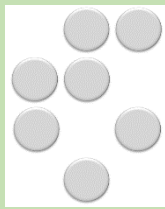

- Anorganski, nekovinski kristalinični in steklasti materiali

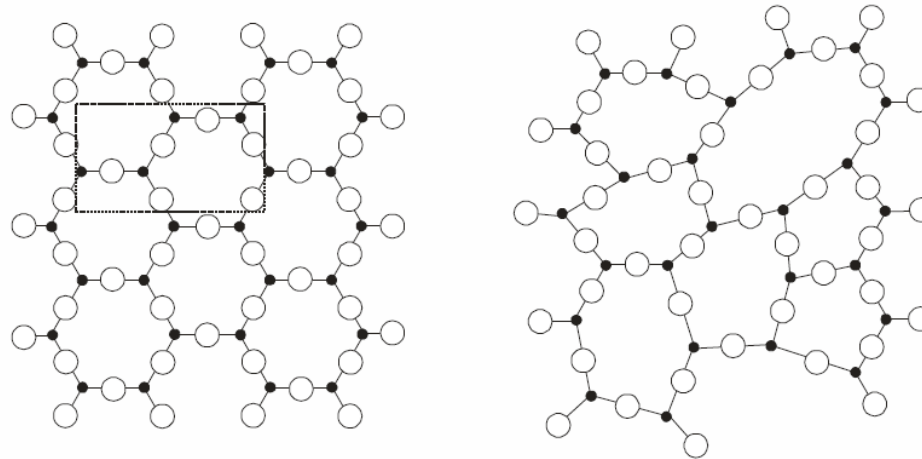

- Množica lastnosti keramičnih materialov:

KERAMIKA

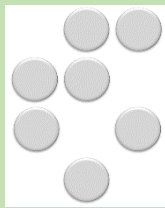

- Anorganski, nekovinski kristalinični in steklasti materiali

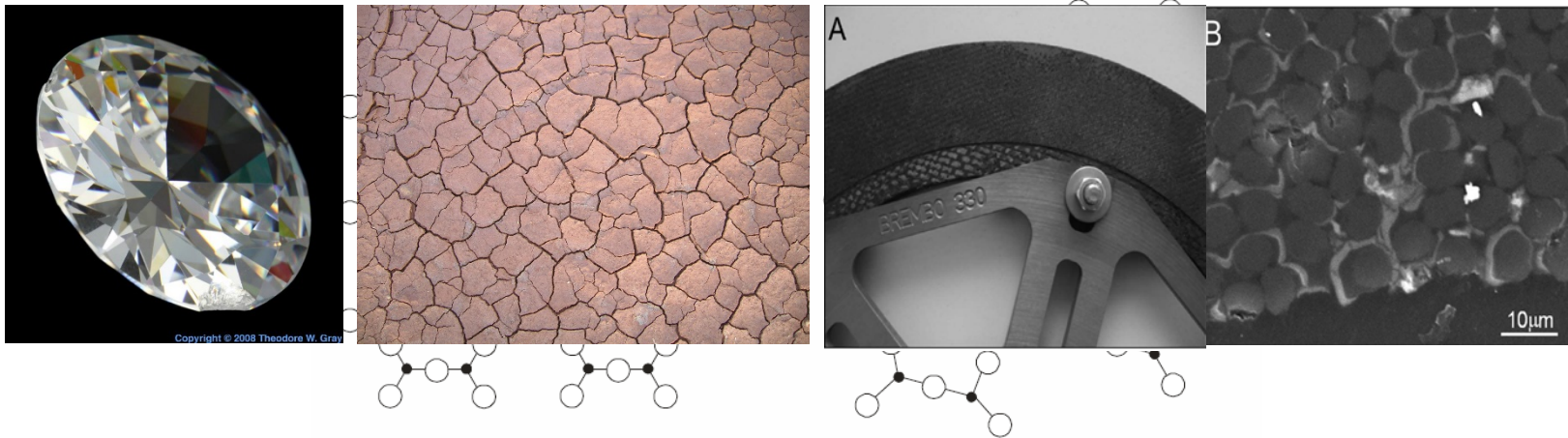

- Množica lastnosti keramičnih materialov:
 - *monokristalinični, polikristalinični ali kompozitni;*

KERAMIKA

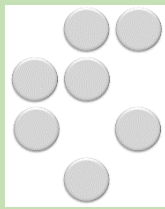

- Anorganski, nekovinski kristalinični in steklasti materiali

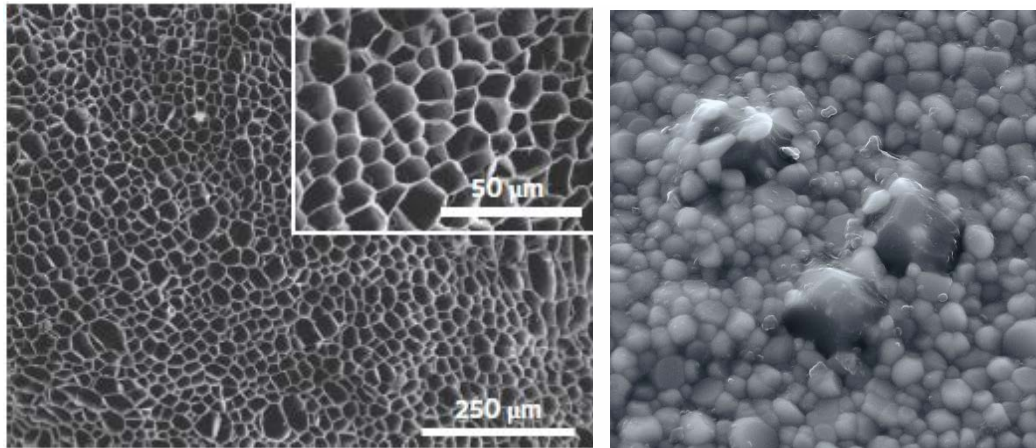

- Množica lastnosti keramičnih materialov:

- *monokristalinični, polikristalinični ali kompozitni;*
- *porozni ali gosti;*

KERAMIKA

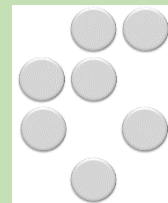

- Anorganski, nekovinski kristalinični in steklasti materiali



- Množica lastnosti keramičnih materialov:

- *monokristalinični, polikristalinični ali kompozitni;*
- *porozni ali gosti;*
- *mehki ali trdi; šibki ali trdni; krhki ali žilavi*

KERAMIKA

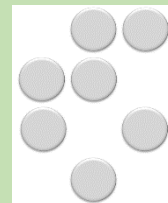

- Anorganski, nekovinski kristalinični in steklasti materiali



- Množica lastnosti keramičnih materialov:

- *monokristalinični, polikristalinični ali kompozitni;*
- *porozni ali gosti;*
- *mehki ali trdi; šibki ali trdni; krhki ali žilavi*
- *opačni ali prosojni*

KERAMIKA

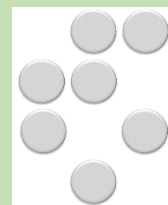

- Anorganski, nekovinski kristalinični in steklasti materiali



- Množica lastnosti keramičnih materialov:

- *monokristalinični, polikristalinični ali kompozitni;*
- *porozni ali gosti;*
- *mehki ali trdi; šibki ali trdni; krhki ali žilavi*
- *opačni ali prosojni*
- *nizka ali visoka temperatura tališča*

KERAMIKA

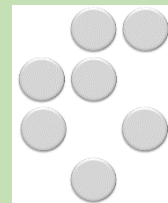

- Anorganski, nekovinski kristalinični in steklasti materiali



- Množica lastnosti keramičnih materialov:

- *monokristalinični, polikristalinični ali kompozitni;*
- *porozni ali gosti;*
- *mehki ali trdi; šibki ali trdni; krhki ali žilavi*
- *opačni ali prosojni*
- *nizka ali visoka temperatura tališča*
- *izolatorji, prevodniki ali superprevodniki*
- *dielektriki*
- *diamagnetni, paramagnetni ali feromagnetni*

KERAMIKA

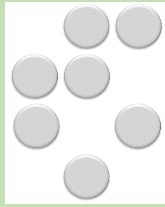

- 7000 BC – Začetki izdelovanja in uporabe



KERAMIKA

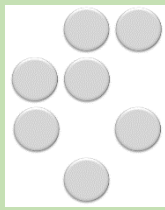

- 7000 BC – Začetki izdelovanja in uporabe



KERAMIKA

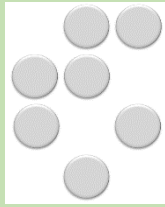

- 7000 BC – Začetki izdelovanja in uporabe



KERAMIKA

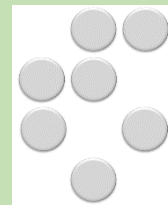

- 7000 BC – Začetki izdelovanja in uporabe
- Oblikovanje, žganje/sintranje

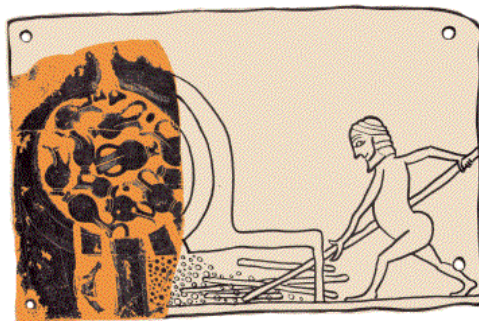

KERAMIKA

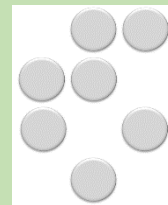

- 7000 BC – Začetki izdelovanja in uporabe
- Oblikovanje, žganje/sintranje

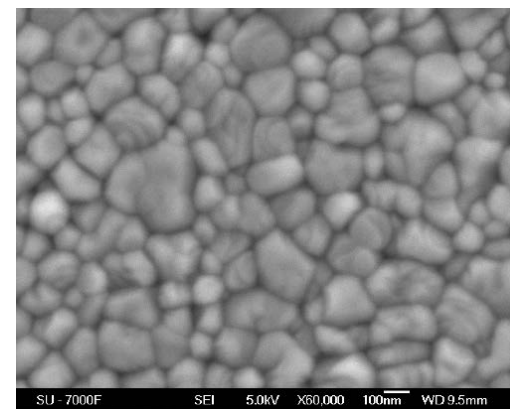
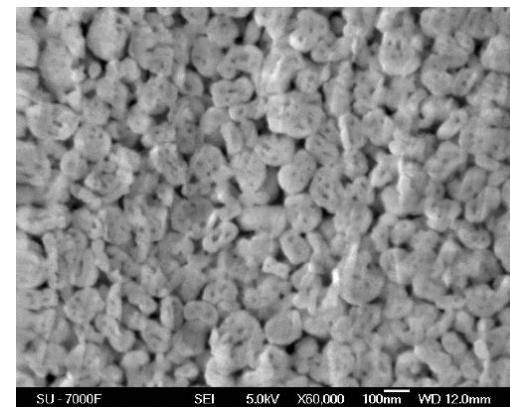
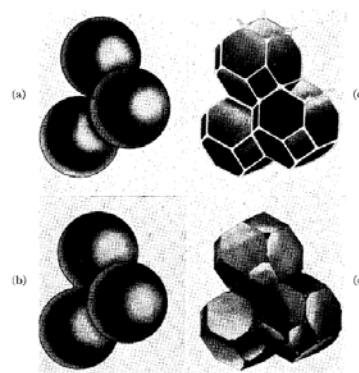
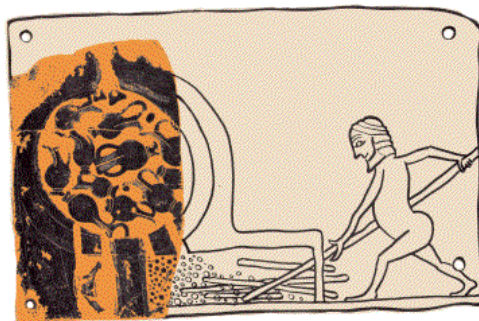

OBLIKOVANJE

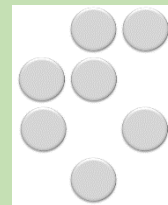

- Mokro – ulivanje v mavčne modele

OBLIKOVANJE

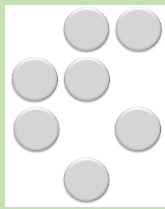

- Mokro – ulivanje v mavčne modele



OBLIKOVANJE

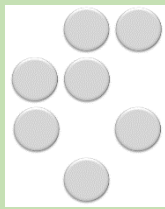

- Mokro – ulivanje v mavčne modele



- Suho – stiskanje granulato, mehansko obdelovanje

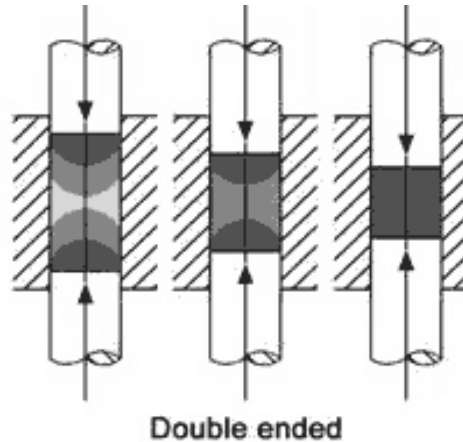
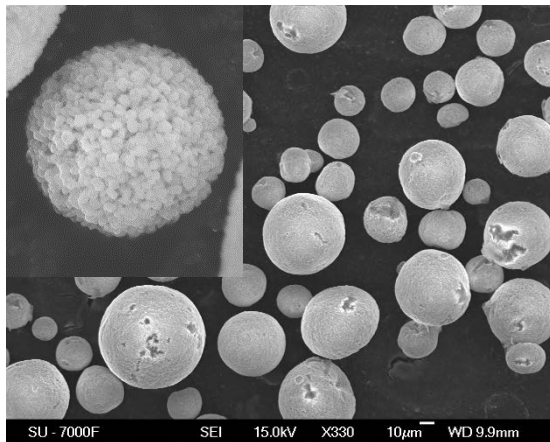

NANOTEHNOLOGIJA

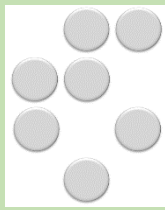

- Manipulacija snovi, ki ima vsaj eno dimenzijo v območju *1–100 nm*.

N

• M

1-

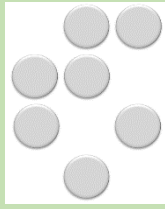

Nanomaterials (1-100 nm)

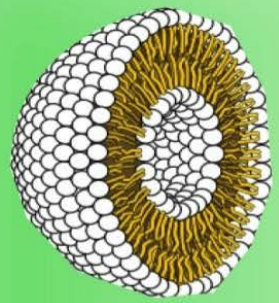
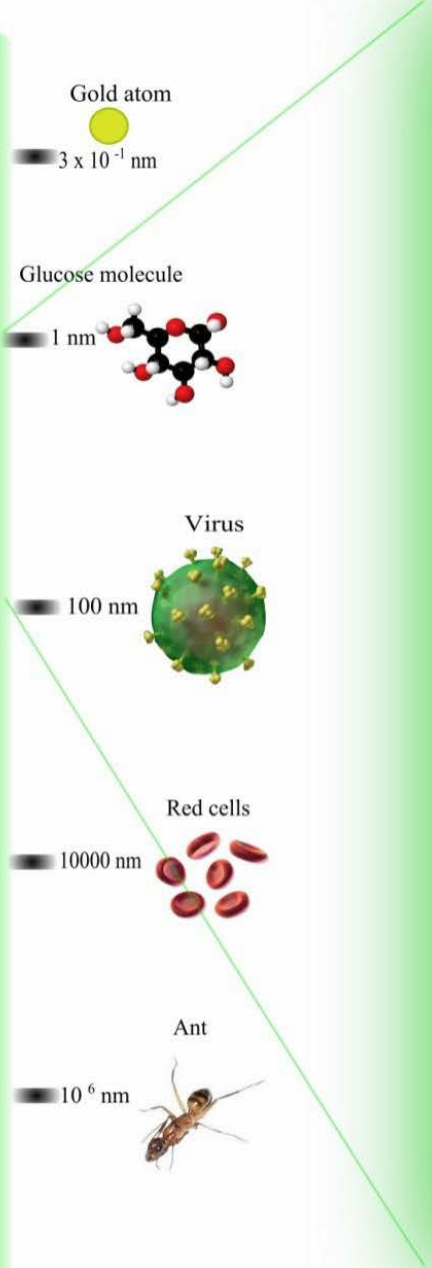
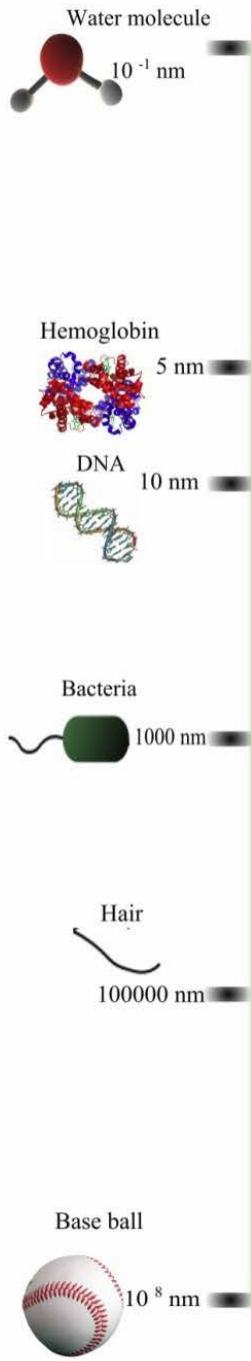

Liposome

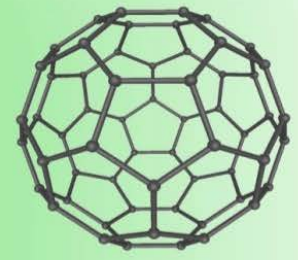

Fullerene

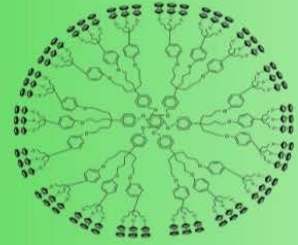

Dendrimer

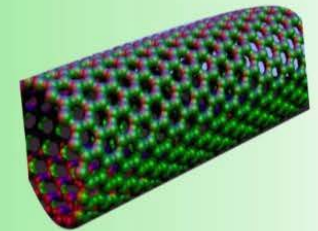

Carbon nanotube

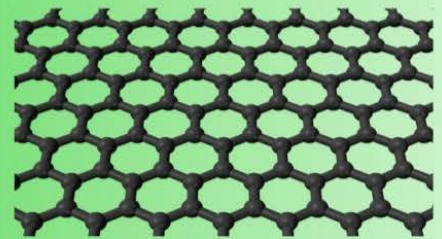

Graphene

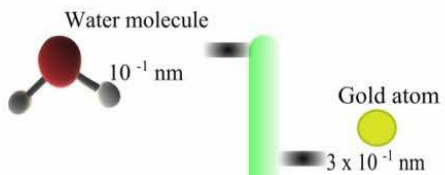
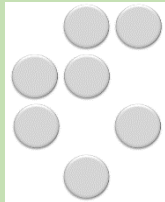

1-

Hemo

D

Bac

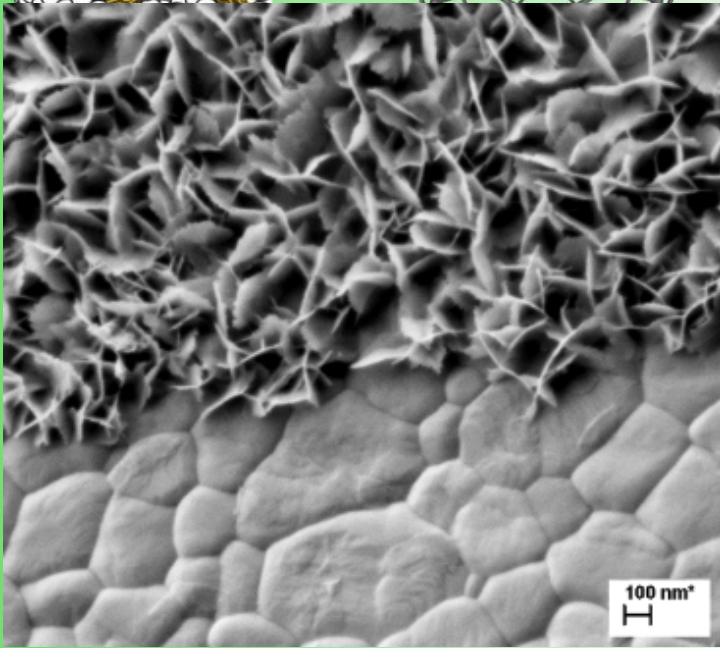
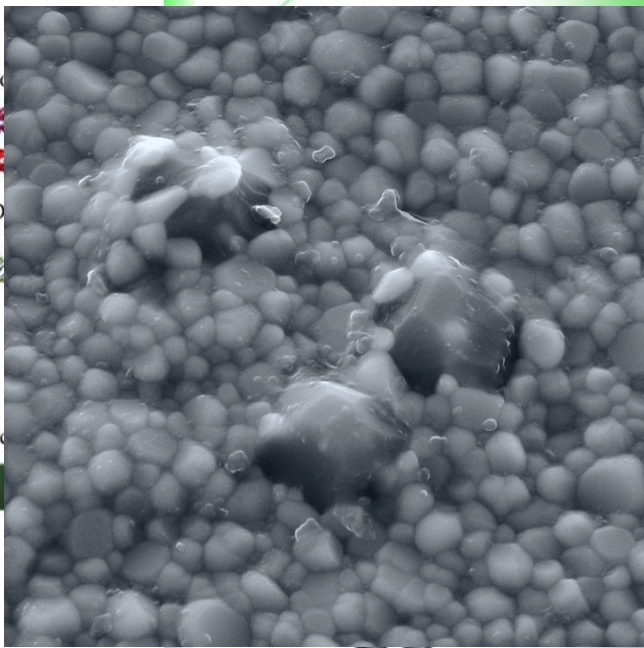

Hair

100000 nm

10^6 nm



Base ball

10^8 nm

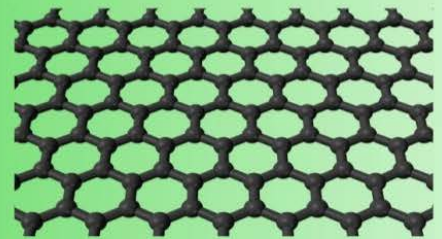

Graphene

NANOTEHNOLOGIJA

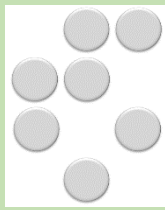

- Manipulacija snovi, ki ima vsaj eno dimenzijo v območju *1–100 nm*.

NANOTEHNOLOGIJA

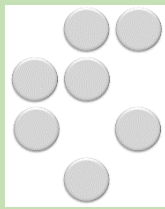

- Manipulacija snovi, ki ima vsaj eno dimenzijo v območju *1–100 nm*.

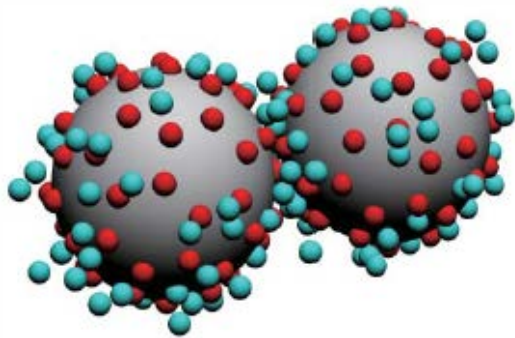

NANOTEHNOLOGIJA

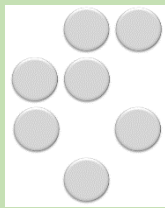

- Manipulacija snovi, ki ima vsaj eno dimenzijo v območju *1–100 nm*.

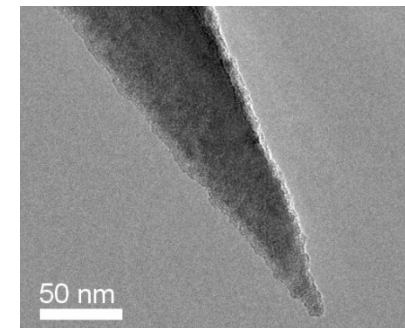
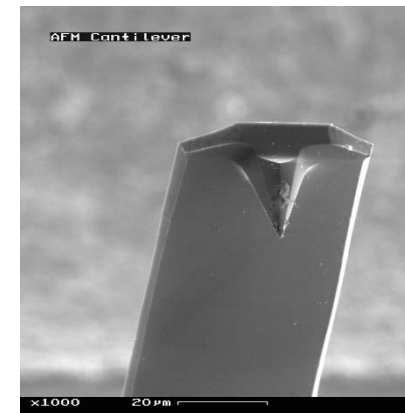
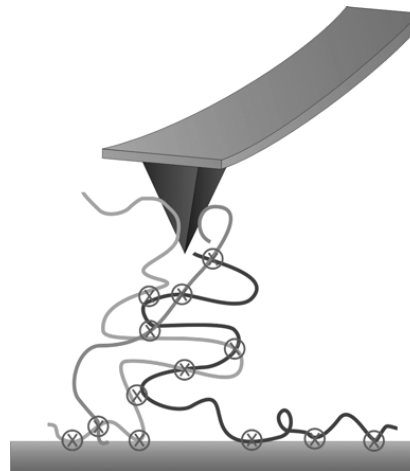
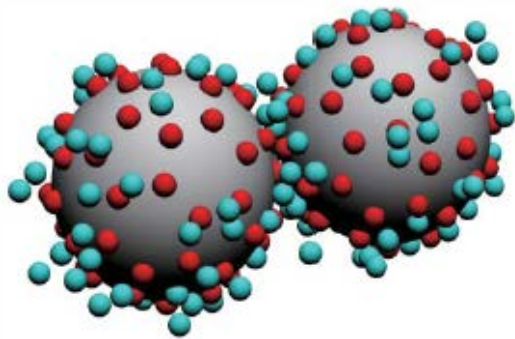

3D TISKANJE KERAMIKE

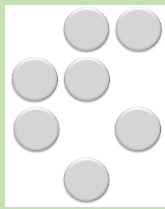

- Aditivno oblikovanje – „sloj po sloj“

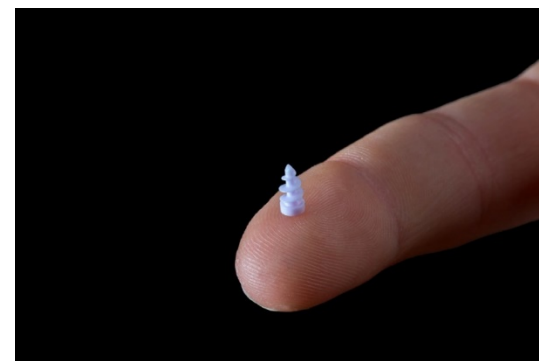
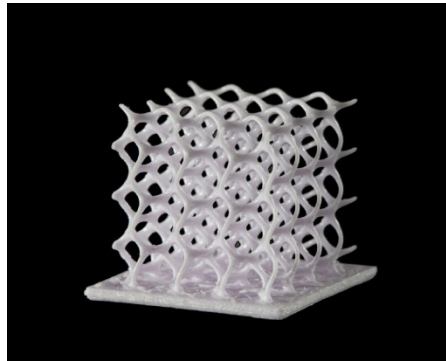

TLAČNO INJEKCIJSKO BRIZGANJE KERAMIKE

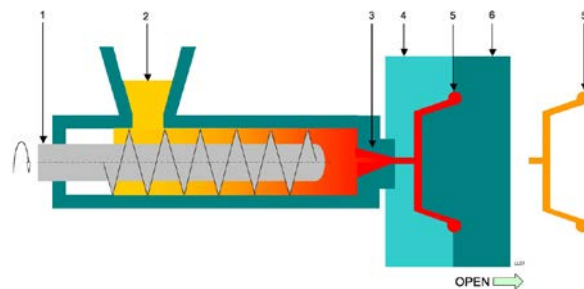
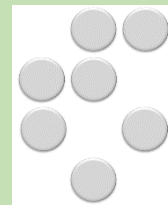

TLAČNO INJEKCIJSKO BRIZGANJE KERAMIKE

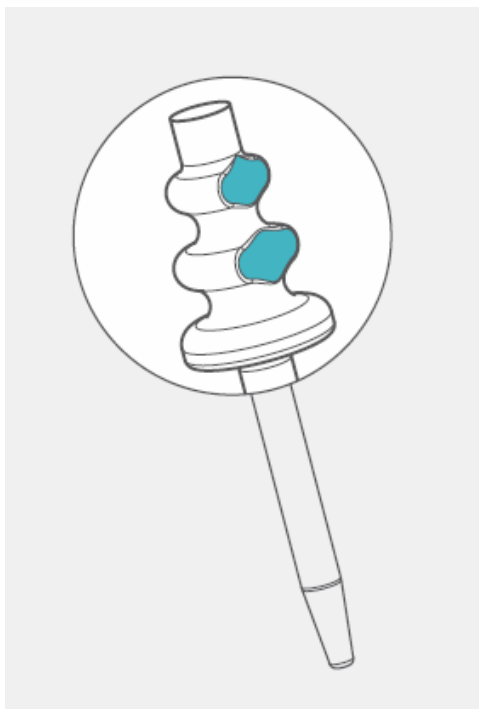
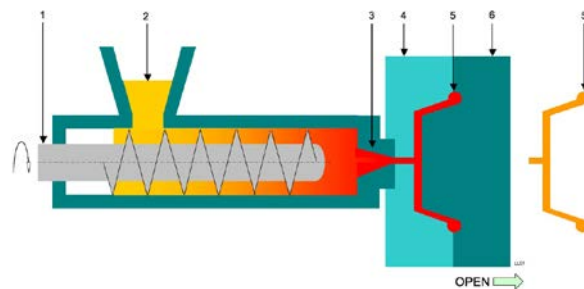
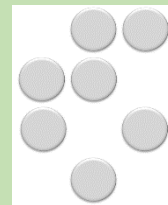

DENTALNA KERAMIKA ZrO_2

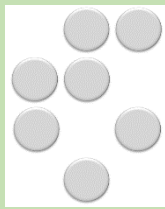

DENTALNA KERAMIKA ZrO_2

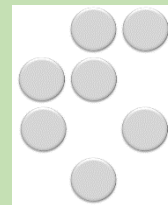

DENTALNA KERAMIKA ZrO_2

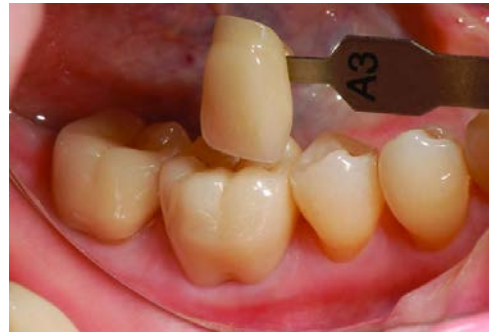
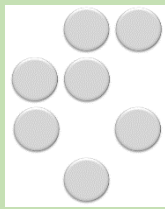

DENTALNA KERAMIKA ZrO_2

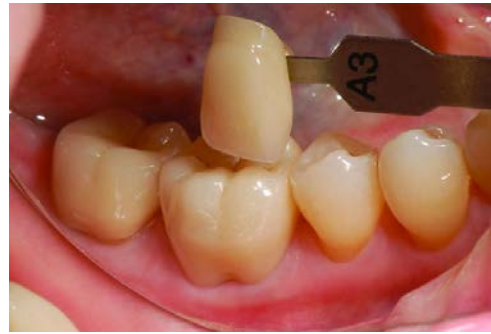
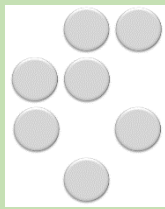

DENTALNA KERAMIKA ZrO_2

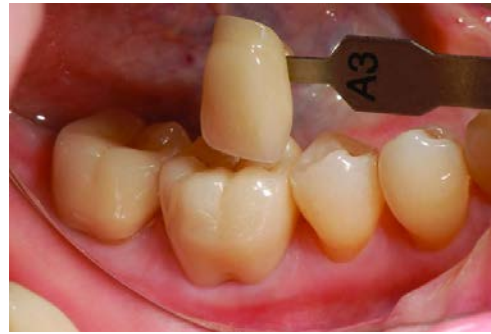
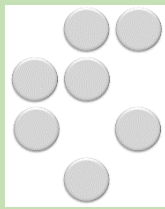

DENTALNA KERAMIKA ZrO_2

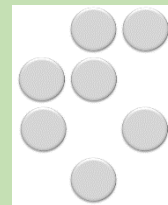

DENTALNA KERAMIKA ZrO_2

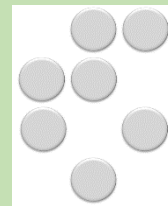

- CAD/CAM postopek



DENTALNA KERAMIKA ZrO_2

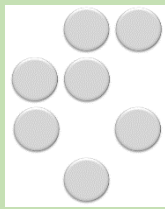

- CAD/CAM postopek

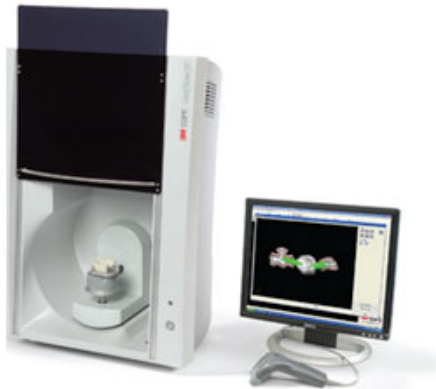

DENTALNA KERAMIKA ZrO_2

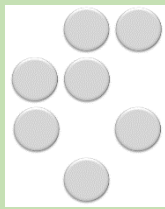

- CAD/CAM postopek

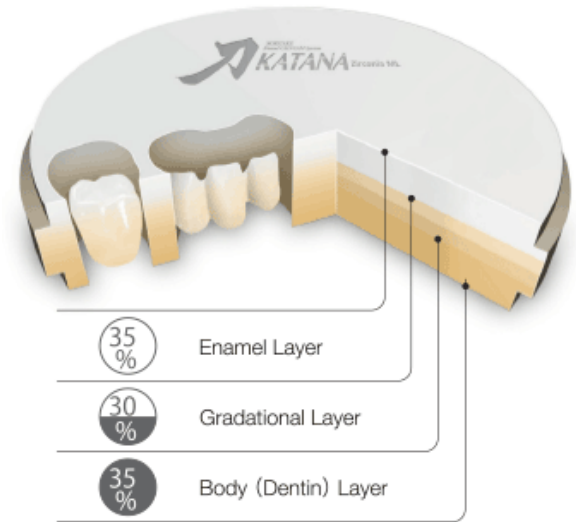
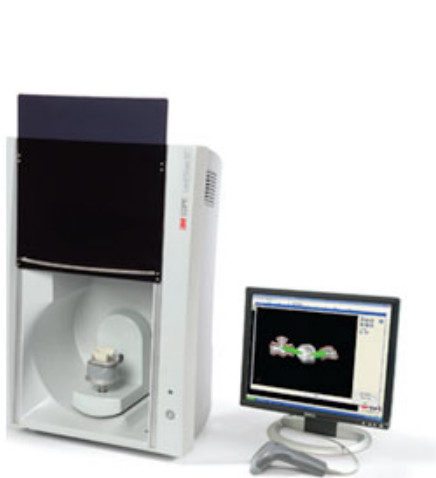

PROSOJNOST KERAMIKE

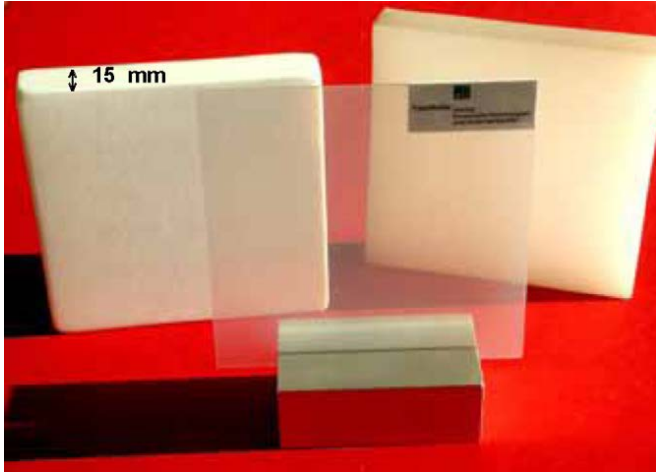
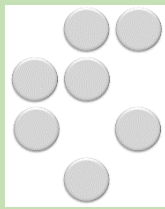

PROSOJNOST KERAMIKE

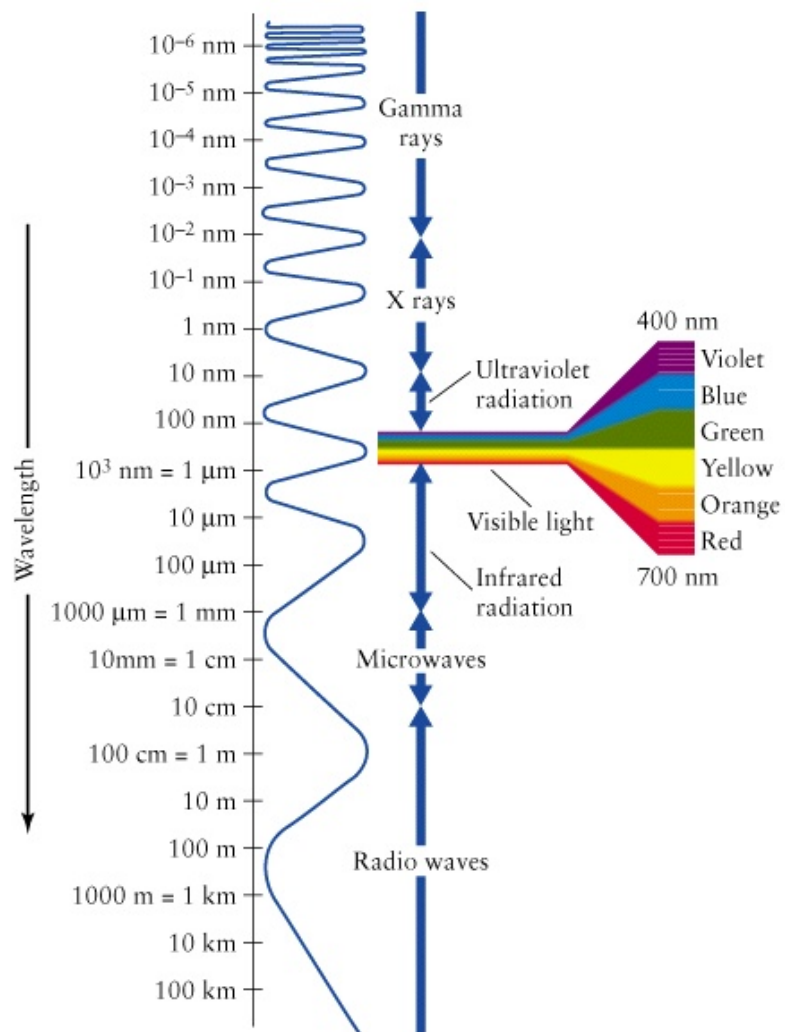
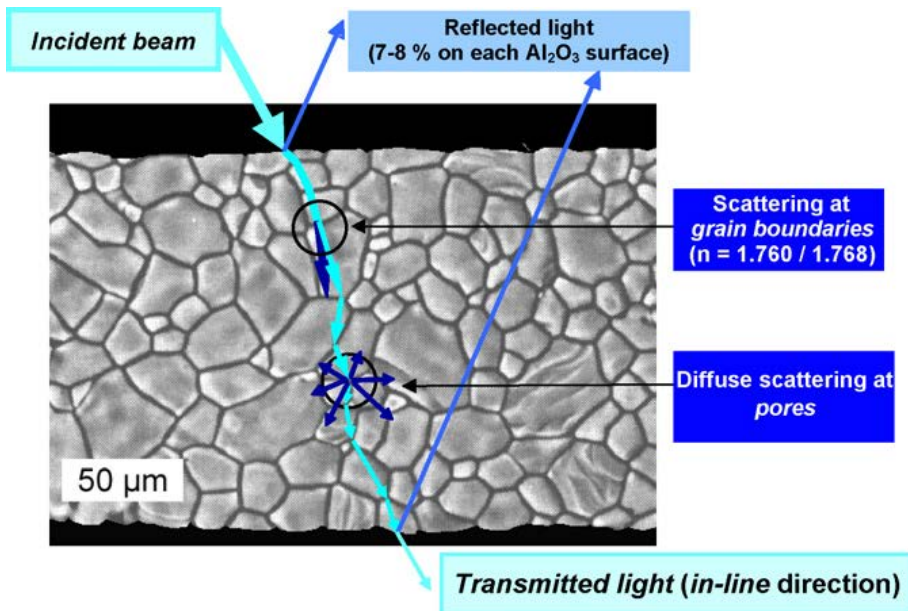
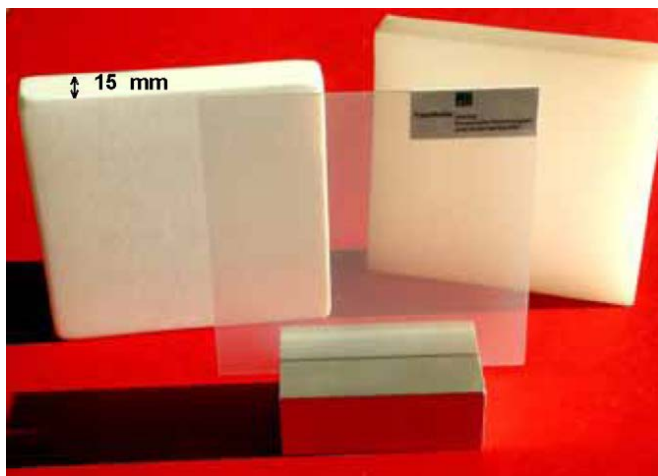
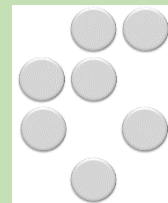

PROSOJNOST KERAMIKE

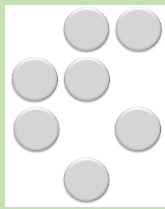

PROSOJNOST KERAMIKE

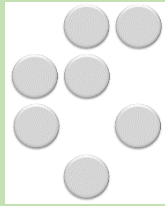

PROSOJNOST KERAMIKE

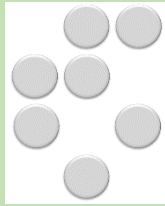

Copyright © 2008 Theodore W. Gray



PROSOJNOST KERAMIKE

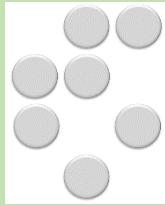

Copyright © 2008 Theodore W. Gray



PROSOJNOST KERAMIKE

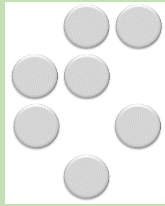

Copyright © 2008 Theodore W. Gray



PROSOJNOST KERAMIKE

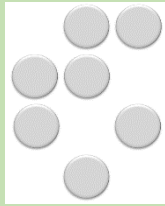

Copyright © 2008 Theodore W. Gray



PROSOJNOST KERAMIKE

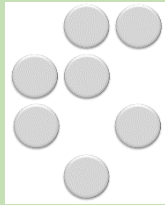

Copyright © 2008 Theodore W. Gray

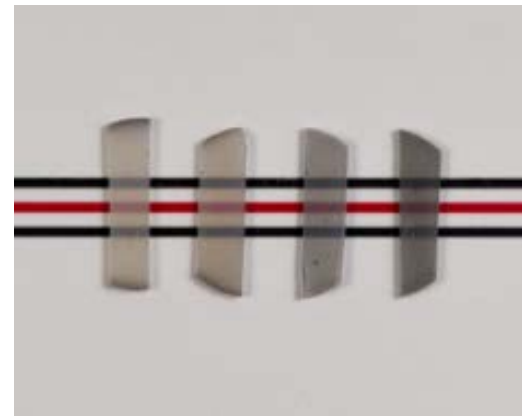
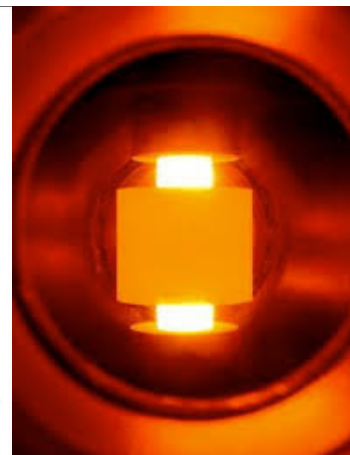
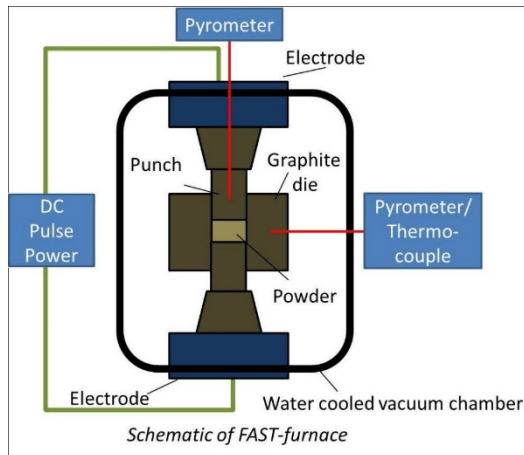

KERAMIKA V AVTOMOBILIH

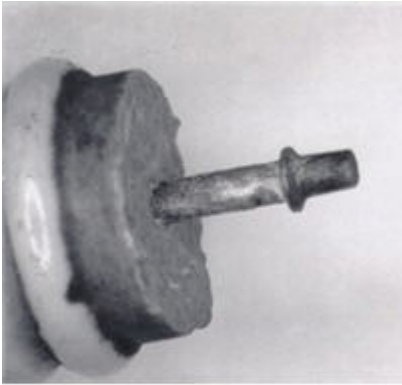
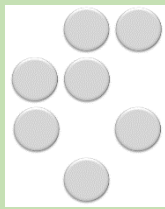

Part of a 1920s-era Champion spark plug.

KERAMIKA V AVTOMOBILIH

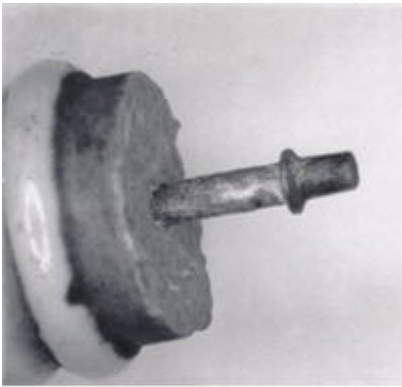
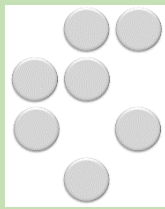

Part of a 1920s-era Champion spark plug.

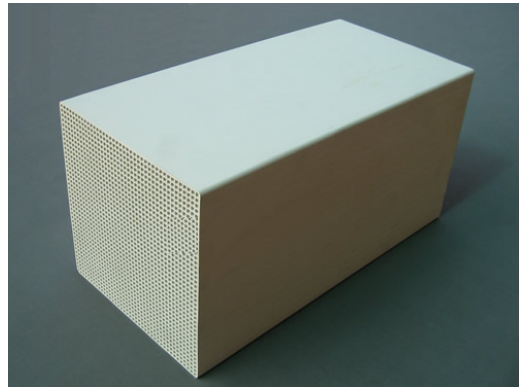

KERAMIKA V AVTOMOBILIH

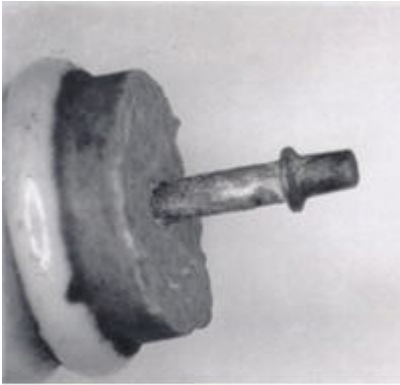
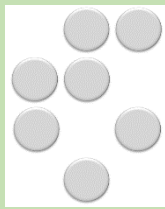

Part of a 1920s-era Champion spark plug.

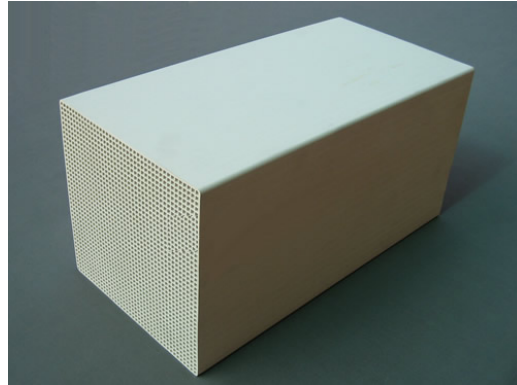

FRIATEC AG

KERAMIKA V AVTOMOBILIH

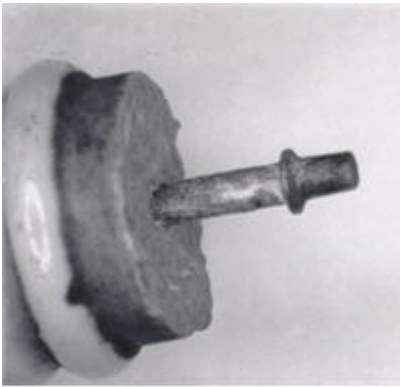
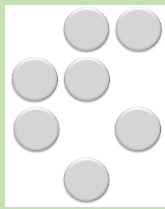

Part of a 1920s-era Champion spark plug.

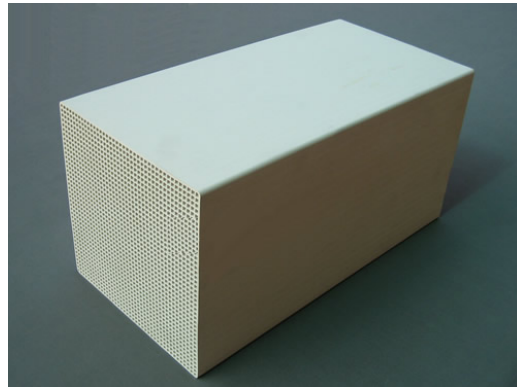

FRIATEC AG



CeramTec

KERAMIKA V AVTOMOBILIH

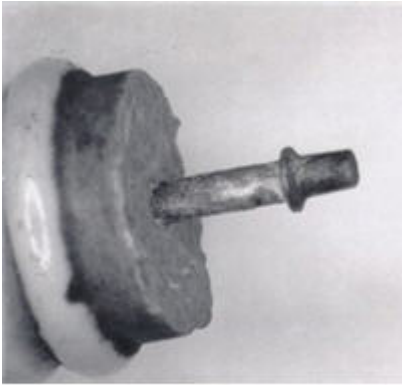
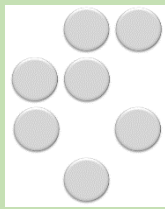

Part of a 1920s-era Champion spark plug.

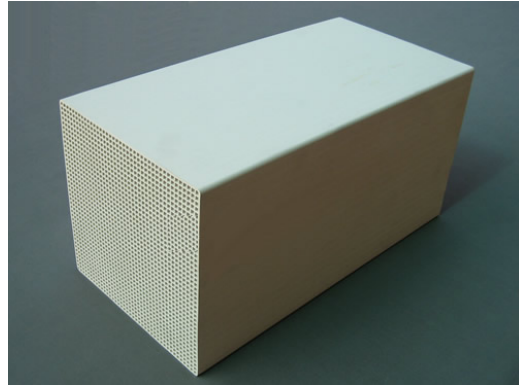

FRIATEC AG



CeramTec

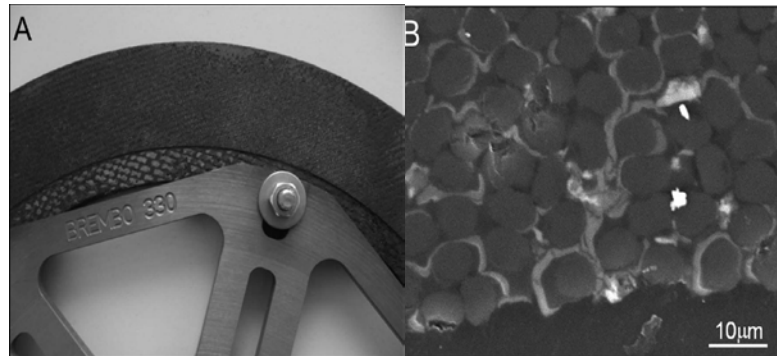

KERAMIČNI SLOJI in PREVLEKE

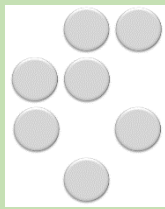

- Gorivne celice s trdim elektrolitom ZrO_2



KERAMIČNI SLOJI in PREVLEKE

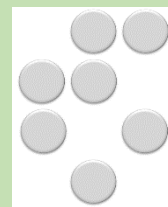

- Gorivne celice s trdim elektrolitom ZrO_2

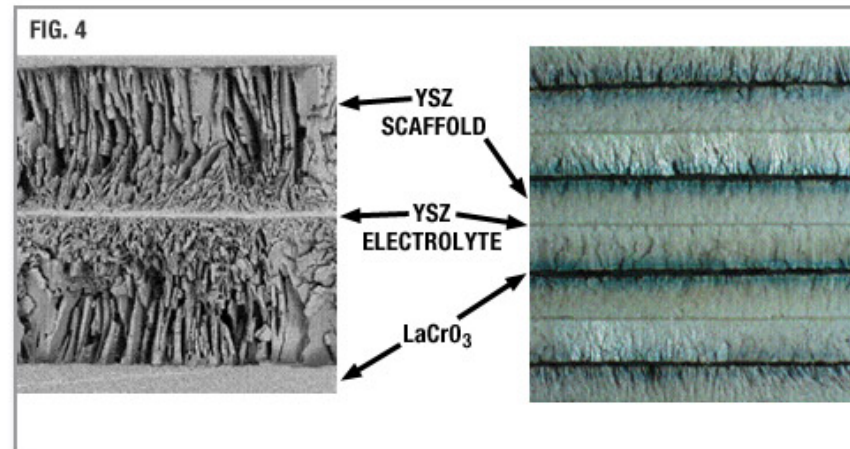
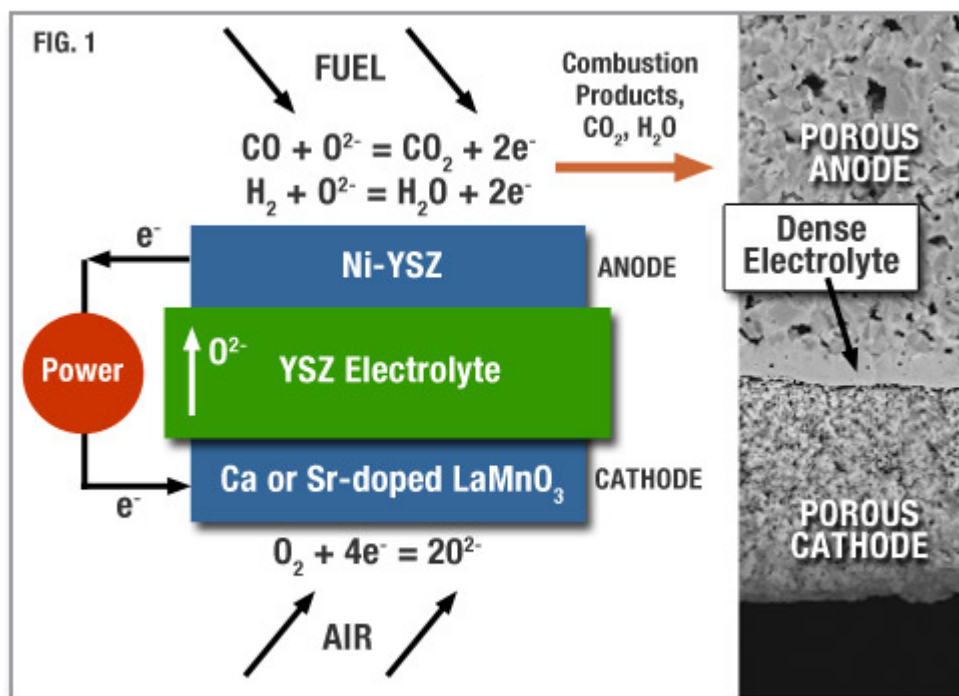

KERAMIČNE PREVLEKE

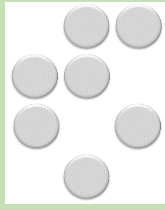

- Ognjevzdržne prevleke ZrO_2

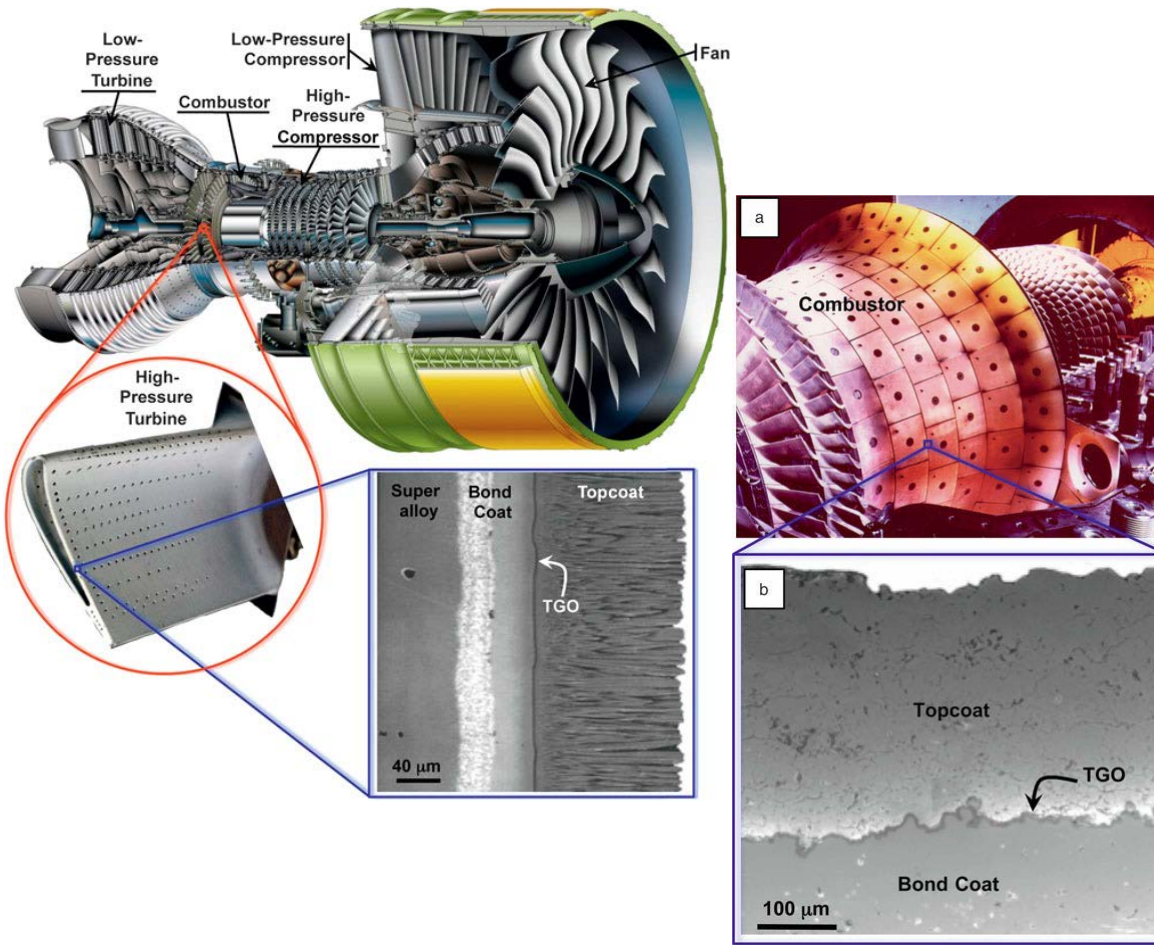

NANOSTRUKTURNE PREVLEKE

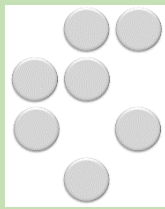

- Adhezivna prevleka Al_2O_3 za dentalno keramiko ZrO_2

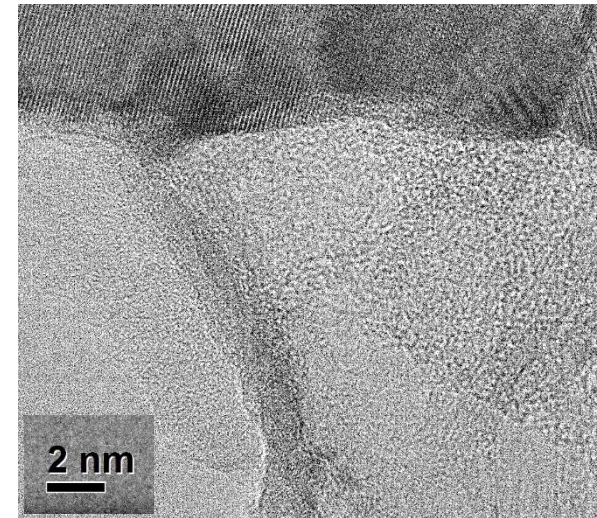
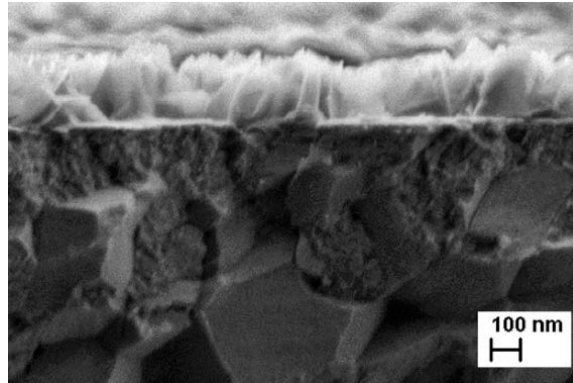
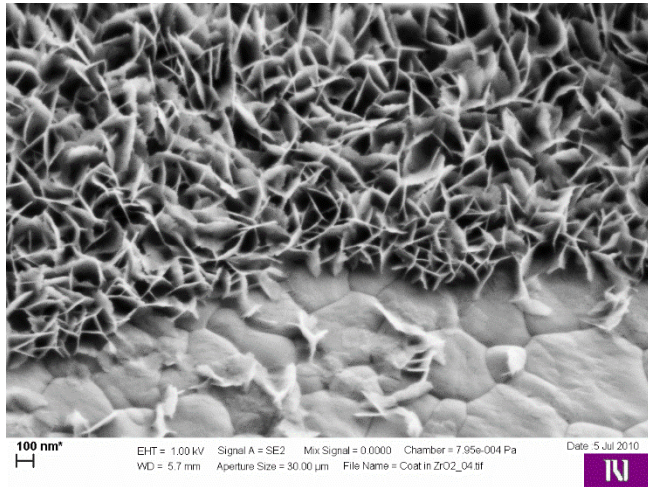

NANOSTRUKTURNE PREVLEKE

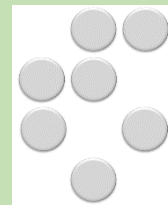

- Adhezivna prevleka Al_2O_3 za dentalno keramiko ZrO_2

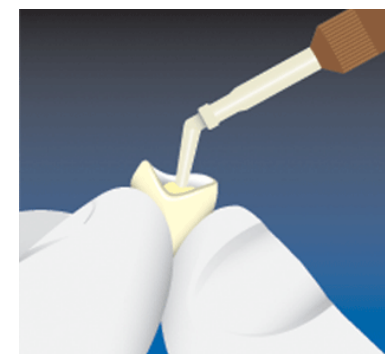
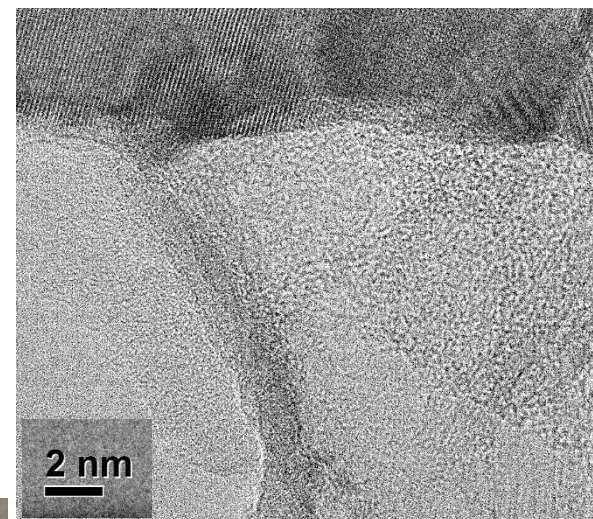
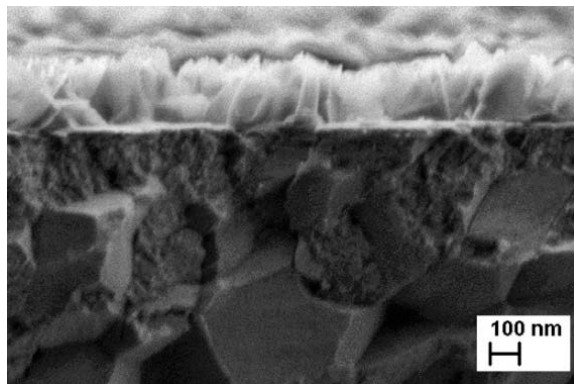
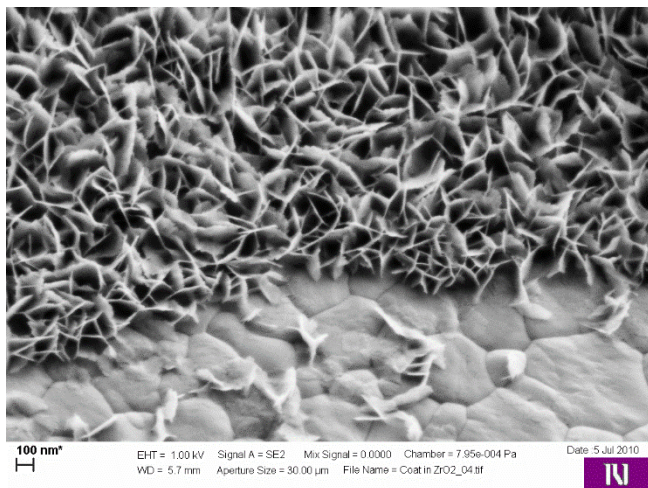

NANOSTRUKTURNE PREVLEKE

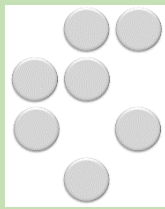

- Samočistilna prevleka

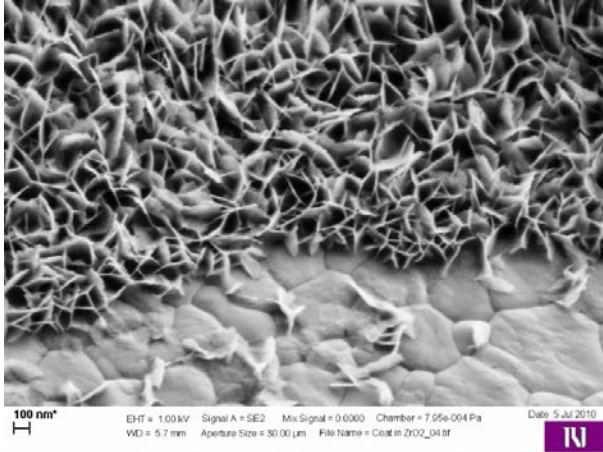

<https://www.youtube.com/watch?v=djgiRPDdH00>

NANOSTRUKTURNE PREVLEKE

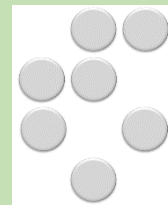

- Samočistilna prevleka

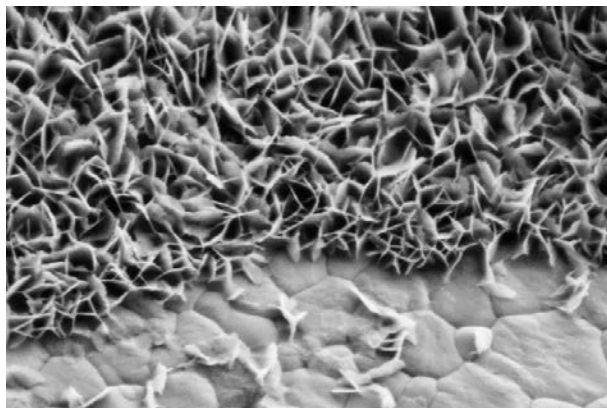

100 nm*
EHT = 1.00 kV Signal A = SE2 Mix Signal = 0.0000 Chamber = 7.95e-004 Pa Date: 5 Jul 2010
WD = 5.7 mm Aperture Size = 30.00 µm File Name = Coat in 2102_04.tif

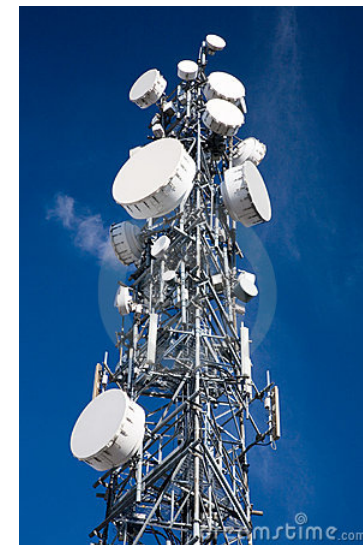

<https://www.youtube.com/watch?v=djgiRPDdH00>

NANOSTRUKTURNE PREVLEKE

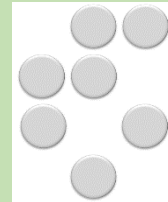

- Samočistilna prevleka

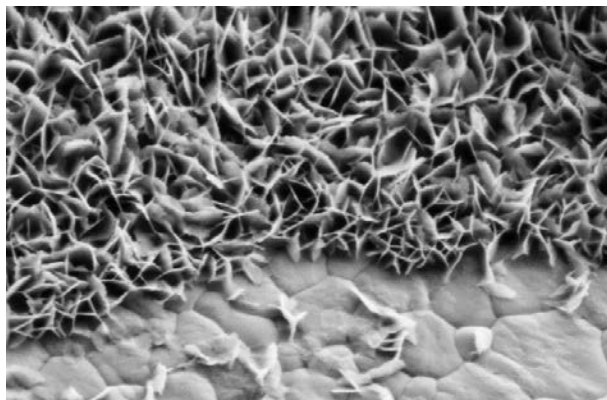

100 nm* EHT = 1.00 kV Signal A = SE2 Mix Signal = 0.0000 Chamber = 7.95e-004 Pa Date: 5 Jul 2010
WD = 5.7 mm Aperture Size = 30.00 μ m File Name = Coat in 2102_04.tif

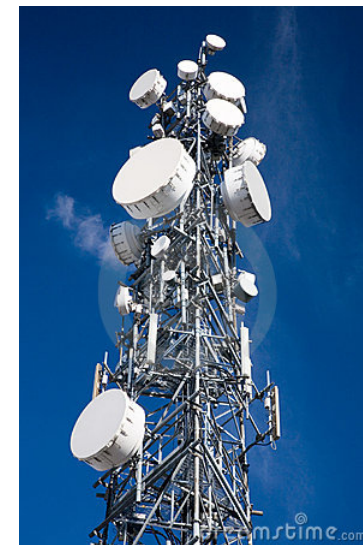
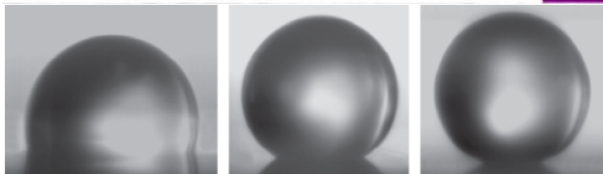

<https://www.youtube.com/watch?v=djgiRPDdH00>

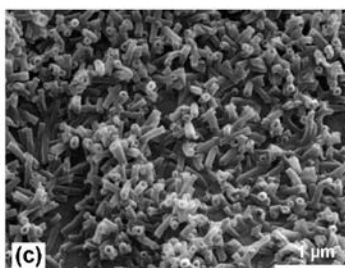
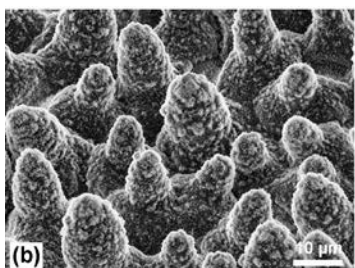
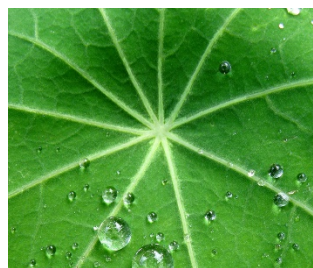

KAJ PA JUTRI?

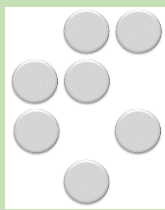

- Lasersko 3D tiskanje keramike



KAJ PA JUTRI?

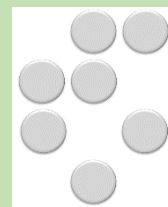

- Lasersko 3D tiskanje keramike



- Baterije – keramični separatorji

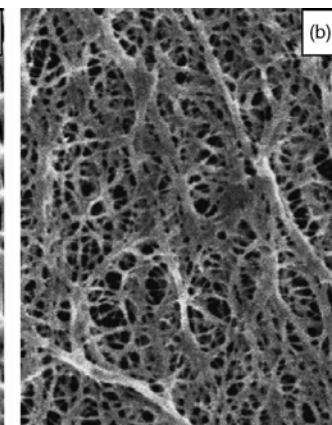
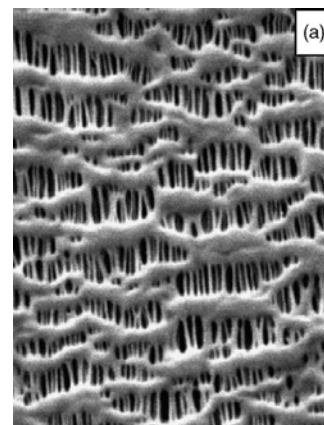
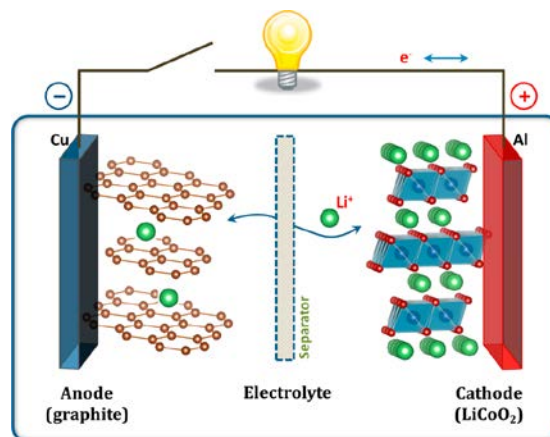

KAJ PA JUTRI?

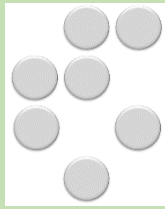

- Termoelektriki

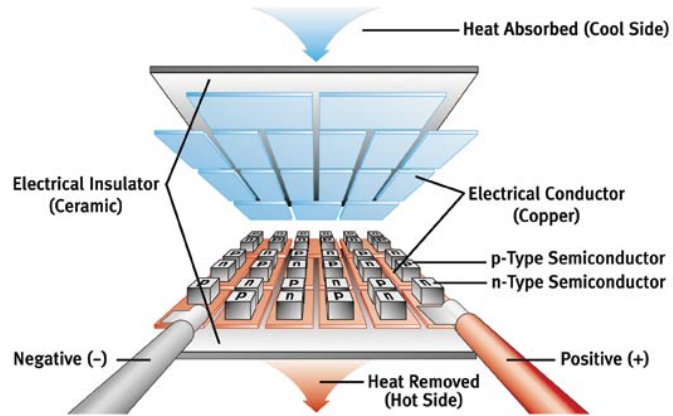

KAJ PA JUTRI?

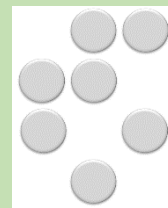

- Termoelektriki

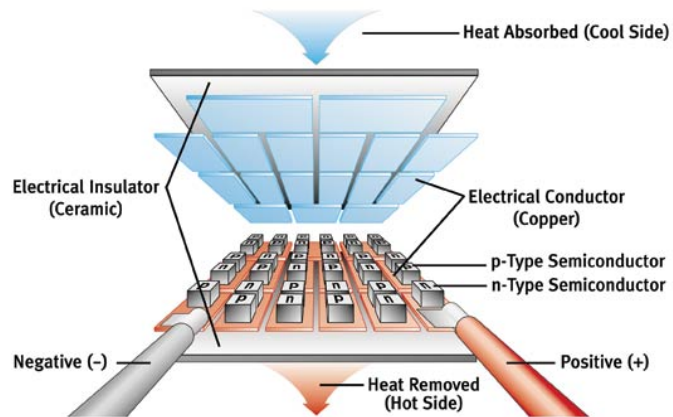

- Nanostrukturne transparentne prevleke



The new PPG windshield blocks 90 percent of the sun's infrared rays.

KAJ PA JUTRI?

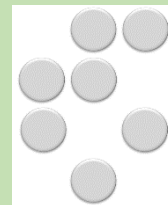

- Termoelektriki

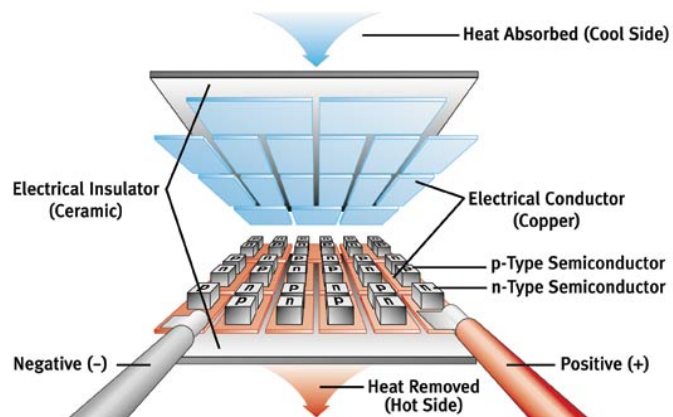

- Nanostrukturne transparentne prevleke



The new PPG windshield blocks 90 percent of the sun's infrared rays.

- Biokeramika – Kostni implantati in „tkivno inženirstvo“

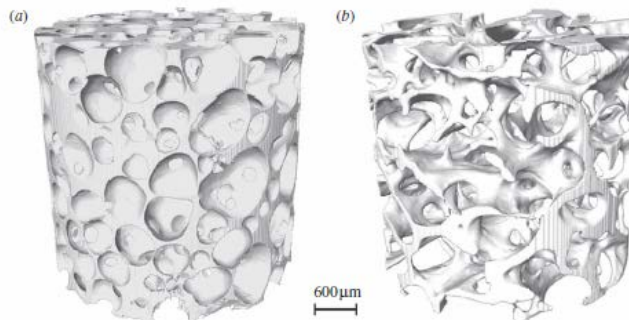
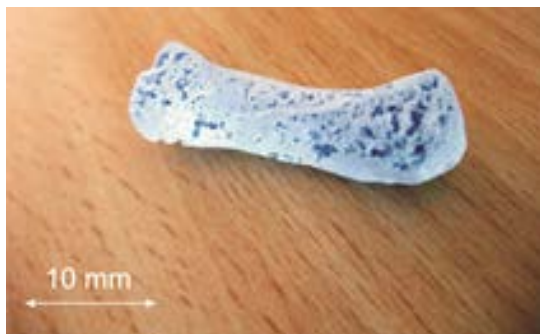

Znanost
na cesti

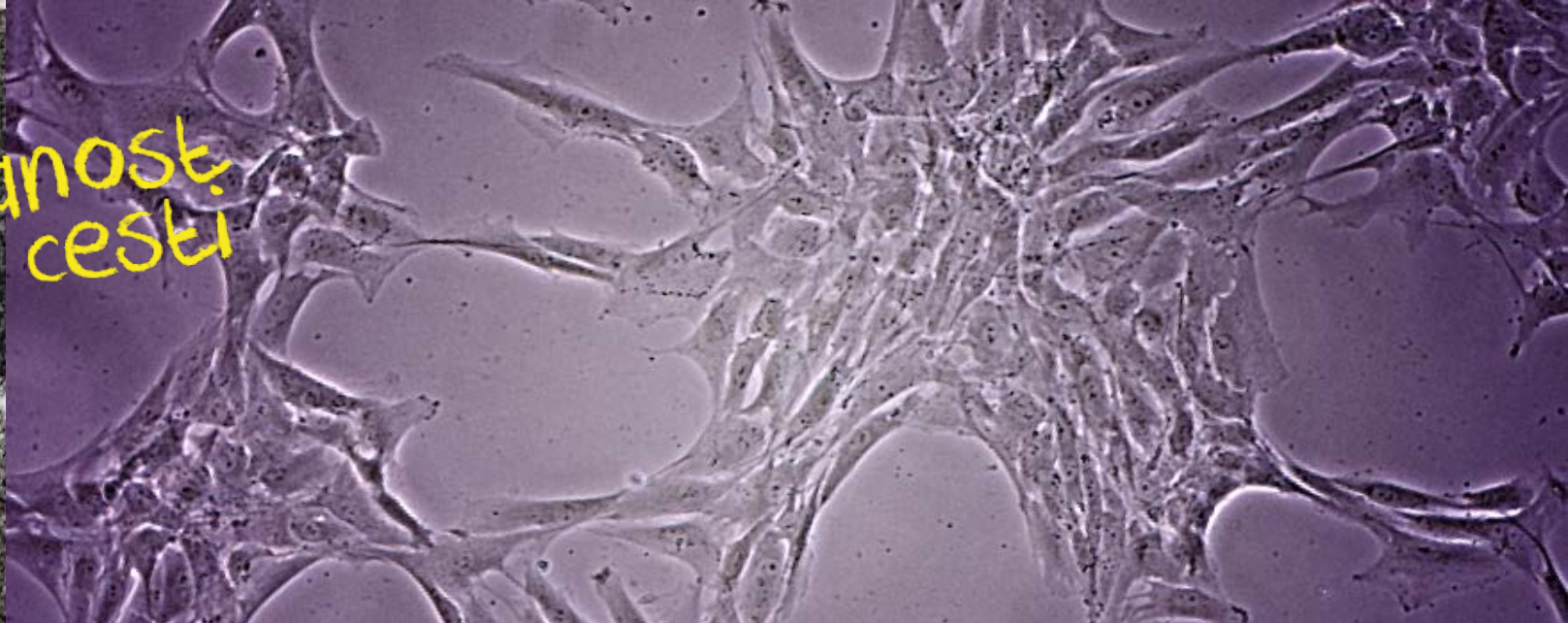

Dragocenosti v biobanki – zdravljenje z matičnimi celicami

13. maj 2015 ob 19h

prof. Miomir Knežević, Educell in Biotehniška fakulteta, UL
Renata Dacinger, TV Slovenija

